

PHILIPS

Data handbook



Electronic
components
and materials

**Components and
materials**

Book C20

1987

Wirewound components

for TV and monitors

WIREWOUND COMPONENTS FOR TV AND MONITORS

	<i>page</i>
Selection guide	
Recommended combinations for colour television	2
Recommended combinations for colour data graphic displays	4
Recommended combinations for monochrome data graphic displays	6
Glass delay lines	8
Degaussing coils	11
 Device specifications	
Line output transformers	13
Linearity correctors	147
Linearity control units	169
Amplitude control units	187
Luminance delay lines	197
Glass delay lines and comb filters	215
Degaussing coils	265
Transformers, chokes and coils	281
Mains transformers	419
 Index of type numbers	458
 Conversion list (catalogue number-to-type number)	461

DATA HANDBOOK SYSTEM

Our Data Handbook System comprises more than 60 books with specifications on electronic components, subassemblies and materials. It is made up of four series of handbooks:

ELECTRON TUBES	BLUE
SEMICONDUCTORS	RED
INTEGRATED CIRCUITS	PURPLE
COMPONENTS AND MATERIALS	GREEN

The contents of each series are listed on pages iv to vii.

The data handbooks contain all pertinent data available at the time of publication, and each is revised and reissued periodically.

When ratings or specifications differ from those published in the preceding edition they are indicated with arrows in the page margin. Where application information is given it is advisory and does not form part of the product specification.

Condensed data on the preferred products of Philips Electronic Components and Materials Division is given in our Preferred Type Range catalogue (issued annually).

Information on current Data Handbooks and on how to obtain a subscription for future issues is available from any of the Organizations listed on the back cover.

Product specialists are at your service and enquiries will be answered promptly.

ELECTRON TUBES (BLUE SERIES)

The blue series of data handbooks comprises:

- T1** **Tubes for r.f. heating**
- T2a** **Transmitting tubes for communications, glass types**
- T2b** **Transmitting tubes for communications, ceramic types**
- T3** **Klystrons**
- T4** **Magnetrons for microwave heating**
- T5** **Cathode-ray tubes**
Instrument tubes, monitor and display tubes, C.R. tubes for special applications
- T6** **Geiger-Müller tubes**
- T8** **Colour display systems**
Colour TV picture tubes, colour data graphic display tube assemblies, deflection units
- T9** **Photo and electron multipliers**
- T10** **Plumbicon camera tubes and accessories**
- T11** **Microwave semiconductors and components**
- T12** **Vidicon and Newvicon camera tubes**
- T13** **Image intensifiers and infrared detectors**
- T15** **Dry reed switches**
- T16** **Monochrome tubes and deflection units**
Black and white TV picture tubes, monochrome data graphic display tubes, deflection units

SEMICONDUCTORS (RED SERIES)

The red series of data handbooks comprises:

- S1 Diodes**
Small-signal silicon diodes, voltage regulator diodes ($< 1,5 \text{ W}$), voltage reference diodes, tuner diodes, rectifier diodes
- S2a Power diodes**
- S2b Thyristors and triacs**
- S3 Small-signal transistors**
- S4a Low-frequency power transistors and hybrid modules**
- S4b High-voltage and switching power transistors**
- S5 Field-effect transistors**
- S6 R.F. power transistors and modules**
- S7 Surface mounted semiconductors**
- S8a Light-emitting diodes**
- S8b Devices for optoelectronics**
Optocouplers, photosensitive diodes and transistors, infrared light-emitting diodes and infrared sensitive devices, laser and fibre-optic components
- S9 Power MOS transistors**
- S10 Wideband transistors and wideband hybrid IC modules**
- S11 Microwave transistors**
- S12 Surface acoustic wave devices**
- S13 Semiconductor sensors**
- *S14 Liquid Crystal Displays**

*To be issued shortly.

INTEGRATED CIRCUITS (PURPLE SERIES)

The NEW SERIES of handbooks is now completed. With effect from the publication date of this handbook the "N" in the handbook code number will be deleted.

Handbooks to be replaced during 1986 are shown below.

The purple series of handbooks comprises:

IC01	Radio, audio and associated systems Bipolar, MOS	new issue 1986 IC01N 1985
IC02a/b	Video and associated systems Bipolar, MOS	new issue 1986 IC02Na/b 1985
IC03	Integrated circuits for telephony Bipolar, MOS	new issue 1986 IC03N 1985
IC04	HE4000B logic family CMOS	new issue 1986 IC4 1983
IC05N	HE4000B logic family – uncased ICs CMOS	published 1984
IC06N	High-speed CMOS; PC74HC/HCT/HCU Logic family	published 1986
IC08	ECL 10K and 100K logic families	New issue 1986 IC08N 1984
IC09N	TTL logic series	published 1986
IC10	Memories MOS, TTL, ECL	new issue 1986 IC7 1982
IC11N	Linear LSI	published 1985
Supplement to IC11N	Linear LSI	published 1986
IC12	I²C-bus compatible ICs	not yet issued
IC13	Semi-custom Programmable Logic Devices (PLD)	new issue 1986 IC13N 1985
IC14N	Microprocessors, microcontrollers and peripherals Bipolar, MOS	published 1985
IC15	FAST TTL logic series	new issue 1986 IC15N 1985
IC16	CMOS integrated circuits for clocks and watches	first issue 1986
IC17	Integrated Services Digital Networks (ISDN)	not yet issued
IC18	Microprocessors and peripherals	new issue 1986*

* The Microprocessors were included in handbook IC14N 1985, so IC18 will replace that part of IC14N.

COMPONENTS AND MATERIALS (GREEN SERIES)

The green series of data handbooks comprises:

- C2 Television tuners, coaxial aerial input assemblies, surface acoustic wave filters**
- C3 Loudspeakers**
- C4 Ferroxcube potcores, square cores and cross cores**
- C5 Ferroxcube for power, audio/video and accelerators**
- C6 Synchronous motors and gearboxes**
- C7 Variable capacitors**
- C8 Variable mains transformers**
- C9 Piezoelectric quartz devices**
- C11 Varistors, thermistors and sensors**
- C12 Potentiometers, encoders and switches**
- C13 Fixed resistors**
- C14 Electrolytic and solid capacitors**
- C15 Ceramic capacitors**
- C16 Permanent magnet materials**
- C17 Stepping motors and associated electronics**
- C18 Direct current motors**
- C19 Piezoelectric ceramics**
- C20 Wire-wound components for TVs and monitors**
- C22 Film capacitors**

SELECTION GUIDE

RECOMMENDED COMBINATIONS FOR COLOUR TELEVISION

90°

Picture tube	A37-573X	A37-590X A37-591X
Deflection unit	AT1205	AT1206
Screen diagonal	37 cm	37 cm
Multipole	AT1052	AT1052
Degaussing coil single insulation	3122 138 99840	3122 138 99840
Mains filter choke	AT4043/90	AT4043/90
Switched mode driver transformer		AT4043/29
Switched mode transformer	AT3010/90	—
Mains transformer	—	TS561
Input choke	—	AT4043/81
Synchronous power pack transformer	—	AT2077/80 or AT2076/80
Line output transformer	AT2079/10	—
Linearity control unit	AT4042/04A or AT4042/91	AT4042/91

110°

Picture tube	A51-540X	
Deflection unit	AT1850	
Screen diagonal	51 cm	
Degaussing coil single insulation double insulation	3122 138 55220 or 3122 138 56320	
Mains filter choke	AT4043/55 or /90	AT4043/55 or /90
Driver transformer	—	AT4043/29
Switched mode transformer	AT3010/110	—
Mains transformer	TS561	TS561
Current sensing transformer	—	AT4043/46
Bridge coil	AT4043/100	AT4043/100
East/west choke	AT4043/60	AT4043/60
Input choke	—	AT4043/16A
Line output transformer	AT2077/81	AT2077/82
Audio choke	—	AT4043/96
Power pack system line choke	—	AT4043/53
Linearity control unit or linearity corrector	AT4042/08A or AT4042/90	AT4042/90

A42-570X AT1215 42 cm	A42-592X A42-593X AT1216 or AT1470 42 cm	A51-570X AT1237 51 cm	A51-590X A51-591X AT1236 or AT1480 51 cm
AT1052 3122 138 99850 AT4043/90 — AT3010/90* — — — AT2079/07* AT4042/04A or AT4042/91	AT1052 3122 138 99850 AT4043/90 AT4043/29 — TS561 AT4043/81 AT2077/80 or AT2076/80 — AT4042/91	AT1052 3122 138 56070 AT4043/90 — AT3010/90 — — — AT2079/10 AT4042/04A or AT4042/91	AT1052 3122 138 56070 AT4043/90 AT4043/29 — TS561 AT4043/81 AT2077/80 or AT2076/80 — AT4042/91

A56-540X AT1860 56 cm		A66-540X AT1870 66 cm	
3122 138 55220 or 3122 138 56320		3122 138 55230 or 3122 138 56310	
AT4043/55 or /90	AT4043/55 or 90 AT4043/29	AT4043/55 or /90	AT4043/55 or /90 AT4043/29
AT3010/110	—	AT3010/110	—
TS561	TS561	TS561	TS561
—	AT4043/46	—	AT4043/46
AT4043/100	AT4043/100	AT4043/100	AT4043/100
AT4043/60	AT4043/60	AT4043/60	AT4043/60
—	AT4043/16A	—	AT4043/16A
AT2077/81	AT2077/82	AT2077/81	AT2077/82
—	AT4043/96	—	AT4043/96
—	AT4043/53	—	AT4043/53
AT4042/08A or AT4042/90	AT4042/90	AT4042/08A or AT4042/90	AT4042/90

RECOMMENDED COMBINATIONS FOR COLOUR DATA GRAPHIC DISPLAYS

	line frequency			
	medium resolution	16 kHz		24 kHz
		high resolution		high resolution
	14 inch	10 inch	14 inch	14 inch
Colour monitor tube assembly	M34EAQ00X01 M34EAQ10X01	250ARB22N-TC03 (M25-100X/N/4130)	M37-103X/N/1020 M37-108X/N/1020 M37-118X/N/1020	M37-103X/N/1020 M37-108X/N/1020 M37-118X/N/1020
Inductance of line deflection coils	1,9 mH	1,93 mH	1,2 mH	1,2 mH
Line output transformer	AT2077/81	AT2076/81	AT2076/81	AT2076/51
Linearity control unit	AT4042/34	AT4042/04A or AT4042/08A	AT4042/08A	AT4042/08A
Driver transformer	AT4043/01	AT4043/01	AT4043/01	AT4043/01
Shift transformer	—	AT4043/09	AT4043/09	AT4043/09
Dynamic focusing transformer	—	—	—	—
Bridge coil	AT4043/68	AT4043/68	AT4043/68	AT4043/68

32 kHz		line frequency	
		45 kHz	64 kHz
high resolution		high resolution	high resolution
14 inch	20 inch	14 inch	20 inch
M37-103X/N/1030 M37-108X/N/1030 M37-118X/N/1030	M51-107X/N/7171	M37-103X/N/1050 M37-108X/N/1050 M37-118X/N/1050	M48JFJ58X32
0,3 mH	0,71 mH	0,14 to 0,16 mH	0,18 mH
AT2076/51	AT2076/51	AT2077/85	AT2076/60
AT4042/32A	AT4042/32A	AT4042/32A	AT4042/32A
AT4043/01	AT4043/01	AT4043/87	2 x AT4043/87+ 1 x AT4043/01
AT4043/09	AT4043/09	AT4043/09	AT4043/09
—	AT4043/67	—	—
AT4043/68	AT4043/68	AT4043/13	AT4043/08A

RECOMMENDED COMBINATIONS FOR MONOCHROME DATA GRAPHIC DISPLAYS

Line frequency	15 to 22 kHz	15 to 22 kHz	15 to 22 kHz
E.H.T.	11 kV	11 kV	11 kV
Number of characters/line	40 to 80	40 to 80	40 to 80
Picture tube	M24-306	M31-336/M31-340	M32EAA series
Screen diagonal	9 in	12 in	14 in
Deflection angle	90°	90°	90°
Format	landscape	landscape	landscape
Deflection unit	AT1077/09	AT1077/05	AT1077/13
Line output transformer	AT2240/16** or AT2140/16B**	AT2140/16B**	AT2140/16B**
Linearity control unit	AT4042/08A or AT4042/46	AT4042/08A or AT4042/46	AT4042/08A or AT4042/46
Line driver transformer	—	—	—
Dynamic focusing transformer	—	—	—
D.C. shift transformer	—	—	—
Amplitude control unit	AT4044/39D	AT4044/39D	AT4044/39D
Transductor	—	—	—

* E.H.T. cable, catalogue number 3122 137 63370, to be ordered separately.

** E.H.T. cable, catalogue number 3122 137 63920, to be ordered separately.

▲ E.H.T. cable, catalogue number 3111 108 34740, to be ordered separately.

▲▲ E.H.T. cable, catalogue number 3122 137 58254, to be ordered separately.

15,6 kHz 17 kV 80 M31-326/ M38-328	21,3 kHz 17 kV 80 M31-326/ M38-328	15 to 25 kHz 17 kV 80 M31-326/ M38-328	15 to 50 kHz 17 kV 100 to 132 M31-326	15 to 50 kHz 17 kV 100 to 132 M38-328	15 to 70 kHz 17 kV 100 to 132 M38-328	125 kHz 17 kV 192 M38-200
12 in/15 in 110° landscape	12 in/15 in 110° landscape	12 in/15 in 110° landscape	12 in 110° landscape	15 in 110° landscape	15 in 110° portrait	15 in 70° portrait
AT1038/41/42 AT2102/04C▲	AT1038/41/42 AT2102/06C▲	AT1038/41/42 AT2076/84*	AT1039/03 AT2076/84*	AT1039/01 AT2076/84*	AT1039/00 AT2076/84*	AT1991 AT2076/54▲
AT4042/08A	AT4042/08A	AT4042/08A	AT4042/08A or AT4042/33A	AT4042/08A or AT4042/33A	AT4042/08A or AT4042/33A	
AT4043/59 — — — —	AT4043/59 AT4043/67 — — —	AT4043/64 AT4043/67 — — —	AT4043/64 — AT4043/29 AT4044/35 —	AT4043/64 — AT4043/29 AT4044/35 —	AT4043/64 — AT4043/29 AT4044/35 —	AT4043/87 — AT4043/29 — AT4041/52

GLASS DELAY LINES

type	DL63	DL680	DL701	DL703
catalogue number	4322 027 84631	4322 027 84661	4322 027 84771 4322 027 84772	4322 027 84831
application	CTV	VLP	CTV/VCR	VCR
system	PAL-Brazil	PAL	PAL-Europe	PAL-Europe
nominal frequency	3,575611 MHz	7,500000 MHz	4,433619 MHz	4,433619 MHz
-3 dB lower limit	2,8 MHz	5,5 MHz	3,43 MHz	3,03 MHz
-3 dB upper limit	4,5 MHz	8,5 MHz	5,23 MHz	5,43 MHz
insertion loss	9 ± 3 dB	max. 17 dB	9 ± 3 dB	9 ± 3 dB
delay time	63486 ± 5 ns	64400 ± 50 ns	63943 ± 5 ns	63935 ± 5 ns
nominal phase	0°	-	180°	180°
drift (+ 10/+ 60 °C)	typ. 5 ns	≤ 10 ns	≤ 5 ns	≤ 5 ns
spurious (3 τ)	≤ -22 dB	≤ -20 dB	≤ -28 dB	≤ -28 dB
spurious ('others)	≤ -30 dB	≤ -30 dB	≤ -33 dB	≤ -26 dB
R1 (input)	560 Ω	150 Ω	390 Ω	390 Ω
R2 (output)	560 Ω	150 Ω	390 Ω	390 Ω
L1 eff. (input)	18 μ H	2,2 μ H	10 μ H	18 μ H
L2 eff. (output)	18 μ H	2,2 μ H	10 μ H	18 μ H
page	217	221	225	229

DL711	DL720	DL721	DL722	DL750
4322 027 84781 4322 027 84782	4322 027 84721	4322 027 84731	4322 027 84741	4322 027 84751 4322 027 84752
CTV	CTV	CTV	CTV	CTV comb f./VCR
PAL/SECAM	PAL-Argentina	PAL-Argentina	PAL-Argentina	NTSC
4,433619 MHz	3,582056 MHz	3,582056 MHz	3,582056 MHz	3,579545 MHz
3,43 NHz	2,8 MHz	2,8 MHz	2,8 MHz	2,8 MHz
5,23 MHz	4,5 MHz	4,5 MHz	4,5 MHz	4,5 MHz
9 ± 3 dB	9 ± 3 dB	9 ± 3 dB	9 ± 3 dB	9 ± 3 dB
63943 ± 5 ns	63929 ± 5 ns	64069 ± 5 ns	64069 ± 5 ns	63555 ± 5 ns
180°	0°	180°	180°	180°
≤ 5 ns	≤ 5 ns	≤ 5 ns	≤ 5 ns	typ. 5 ns
≤ -33 dB*	≤ -22 dB	≤ -22 dB	≤ -22 dB	≤ -22 dB
≤ -33 dB*	≤ -28 dB	≤ -28 dB	≤ -28 dB	≤ -28 dB
390 Ω	560 Ω	560 Ω	390 Ω	560 Ω
390 Ω	560 Ω	560 Ω	390 Ω	560 Ω
10 μH	18 μH	18 μH	10 μH	18 μH
10 μH	18 μH	18 μH	10 μH	18 μH
233	237	237	237	241

* Spurious signals measured in frequency range 3,9 to 4,75 MHz.

GLASS DELAY LINES/COMB FILTERS

type	DL752	DL872	DL875	DL876	CF873
catalogue number	4322 027 84882	4322 027 84841	4322 027 84501	4322 027 84511	4322 027 84581
application	VCR comb filter	VCR comb filter	VCR comb filter	VCR comb filter	VCR comb filter
system	NTSC	PAL-Europe	PAL-Brazil	PAL-Argentina	PAL-Europe
nominal frequency	3,579545 MHz	4,433619 MHz	3,575611 MHz	3,582056 MHz	4,433619 MHz
-3 dB lower limit	3,08 MHz	3,93 MHz	3,08 MHz	3,08 MHz	3,93 MHz
-3 dB upper limit	4,08 MHz	4,93 MHz	4,08 MHz	4,08 MHz	4,93 MHz
insertion loss	10 ± 3 dB	18 ± 3 dB	18 ± 3 dB	18 ± 3 dB	18 ± 3 dB
delay time	64 μs	128 μs	128 μs	128 μs	128 μs
spurious (2τ)	≤ -20 dB	≤ -12 dB	≤ -15 dB	≤ -15 dB	≤ -18 dB
spurious (3τ)	≤ -18 dB				
spurious ('others')	≤ -26 dB	≤ -23 dB	≤ -20 dB	≤ -20 dB	≤ -23 dB
comb depth at f_0	≥ 24 dB	≥ 20 dB	≥ 18 dB	≥ 18 dB	≥ 20 dB
comb depth at f_+	≥ 10 dB	≥ 10 dB	≥ 10 dB	≥ 10 dB	≥ 12 dB
comb depth at f_-	≥ 10 dB	≥ 10 dB	≥ 10 dB	≥ 10 dB	≥ 12 dB
page	245	249	253	257	261

Note: f_0 = 4,42971 MHz

f_+ = 4,92971 MHz

f_- = 3,92971 MHz

DEGAUSSING COILS

Screen diagonal of picture tube	10 inch 11 inch 12 inch	14 inch	16 inch	20 inch	20 inch	20 inch 22 inch	26 inch
Degaussing system	single coil	single coil	single coil	single coil	double coil	double coil	double coil
Mounting	twisted loop	asymmetrical	asymmetrical	asymmetrical	top + bottom	top + bottom	top + bottom
Ampere-turns	500	600	600	700	2 x 300	2 x 300	2 x 300
Catalogue number of degaussing coil 3122 138 single insulation double insulation	56310	99840 51860	99850 51850	56070 56170	55920	55220 56320	55230 56310
Diameter	435 mm	300 mm	330 mm	435 mm	385 mm	385 mm	435 mm
Mains voltage	220/240 V	220/240 V	220/240 V	220/240 V	110/220 V	110/220 V	110/220 V
Resistance	8,6 Ω^*	21,7 Ω	26,3 Ω	19,5 Ω	11,4 Ω	11,5 Ω	8,6 Ω
Number of turns	52	97	107	120	65	49	52

* Resistor 10 Ω to be connected in series.

LINE OUTPUT TRANSFORMERS

DIODE-SPLIT LINE OUTPUT TRANSFORMER

- Three-layer e.h.t. coil, focus tap for hi-bi
- Aluminium foil primary winding
- Piggy-back type
- For Data Graphic Displays

QUICK REFERENCE DATA

For transistor line output stages

	deflection angle	110°	90°
I_{eht}		max. 1,5 mA	max. 1 mA
E.H.T.		25 kV	25 kV
$R_i(\text{eht})$		1,86 M Ω	2,45 M Ω
$I_{\text{p-p}}$ deflection (incl. 6% overscan)		5,3 A	2,85 A
Supply voltage ($V_{\text{B}'}$)		151 V	151,5 V
Supply current (I_{average}) at		477 mA ($I_{\text{eht}} = 1,5$ mA)	291 mA ($I_{\text{beam}} = 1$ mA)
Voltages of primary windings *		$V_{\text{p}} = +114, +520$ $+1060, +1090$	$+112, +515$ $+1050, +1080$
Voltages of auxiliary windings		$V_{\text{p}} = -280, -149, +64,$ $+227, +326$	$-275, -146, +62$ $+223, +322$
		picture tube heater voltage	

APPLICATION

This transformer has been designed to provide the required scanning amplitude for 110° and 90° colour picture tubes in transistor equipped receivers presenting 625 lines at 50 fields per second (CCIR) or 525 lines at 60 fields per second (USA).

It is intended for use in conjunction with:

	deflection angle	110°	90°
– deflection unit		AT1870, AT1860, AT1850	AT1235/00
– bridge coil		AT4043/68	AT4043/68
– linearity control unit		AT4042/08A or /30	AT4042/04A or /90
– line output transistor		BU508A	BU508A
– screened e.h.t. cable with a length of 1 m; catalogue number 3122 137 58254.			

DESCRIPTION

The magnetic circuit of the transformer comprises 2 Ferroxcube U-cores, screwed together. The primary winding of aluminium foil and the secondary windings are situated on one leg of the core. The e.h.t. winding is moulded in flame retarding polyester, meeting the self-extinguishing requirements of IEC 65, para. 14.4 and UL492, para. 280-SE1. The transformer has 2 M3 screw-studs for mounting.** External circuit connection is made to connecting pins, positioned as indicated in Fig. 1, enabling the unit to be soldered directly into a printed-wiring board (Fig. 2).

* D.C. component on these pulses is $V_{\text{B}'}$ (see Fig. 3).

** For mounting on the printed-wiring board a washer of 20 mm in diameter has to be used. Tightening torque on printed-wiring board: 500 + 100 mNm.

MECHANICAL DATA

Dimensions in mm

Outlines

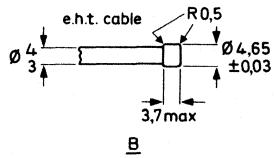
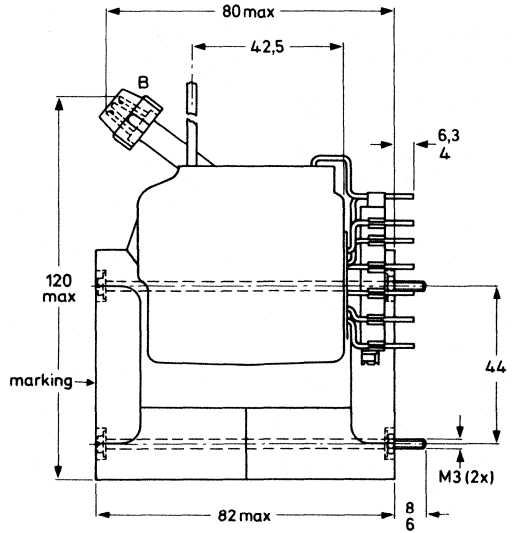
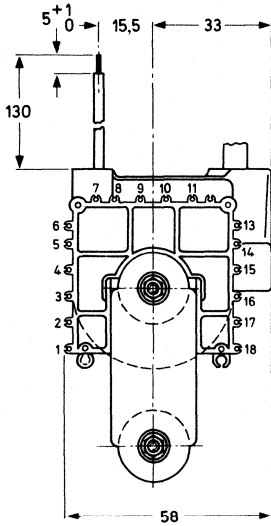

728505L

Fig. 1.

Solderability in accordance with IEC 68, Test T

MOUNTING

The transformer may be mounted on either a printed-wiring board or, under certain conditions, on a metal chassis. Two securing studs (M3) are provided. The fit of the connecting and the mounting pins in a printed-wiring grid with a pitch of 2,54 mm is illustrated in Fig. 2.

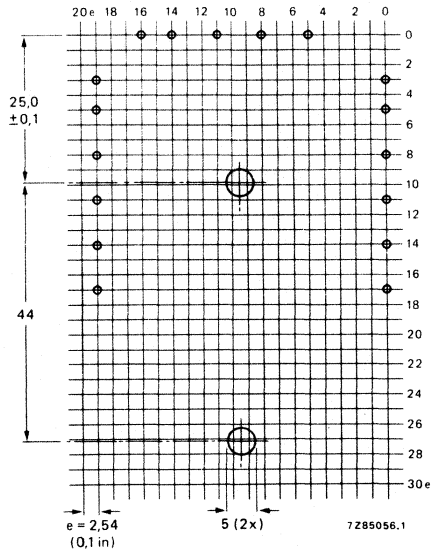

Fig. 2 Hole pattern for mounting on a printed-wiring board (solder side). Grid hole diameter $1,3 \pm 0,1$ mm.

Whether the transformer is board or chassis mounted, **the core must be earthed.**

Temperature

The operating temperature of the e.h.t. coil should not exceed $+85\text{ }^{\circ}\text{C}$ under worst conditions, i.e. taking into account:

- over-voltage on the coils;
- low atmospheric pressure (at high altitudes) implying bad cooling by convection;
- high ambient temperature (up to $45\text{ }^{\circ}\text{C}$).

To satisfy this requirement it is recommended to provide sufficient flow of cool air around the transformer.

Distances

The following minimum distances between the transformer and neighbouring conductive flat surfaces must be maintained:

From the e.h.t. coil radially, 10 mm

From the e.h.t. coil axially, 10 mm

Sharp edges of conductive parts must have greater distances than given above.

The transformer, leads and components carrying high voltage pulses, should be kept free from metal particles, solder drops etc.

ELECTRICAL DATA with 110° COLOUR PICTURE TUBES

E.H.T. supply	I_{eht} e.h.t. $R_{\text{i(eht)}}$	mA kV M Ω	0,03 25,0	1 23,2 -1,86-	1,5 22,2
Power supply	V_{B} $V_{\text{B}'}$	V	158,5	158,5	158,5
			151	147,2	145,0
Output transistor	I_{average} V_{CEM} + I_{CEM}	mA	259	397	477
		V	1240	1210	1190
		A	3,5	3,6	3,65
Deflection	$I_{\text{p-p}}$ t_{flyback} Overscan	A	5,3	5,2	5,15
		μs	11,4	-	-
		%	6	-	6,5
V_{focus}		kV	8,6	8,1	7,8
Auxiliary windings: picture tube heater voltage V_{3-1} (r.m.s.) peak voltages at		V	9,04	8,74	8,54
pin 2	V_2	V	-280		
pin 6	V_6	V	-149		
pin 4	V_4	V	+64		
pin 11	V_{11}	V	+227		
pin 8	V_8	V	+326		
pin 9	V_9 *	V	+114		
pin 14	V_{14} *	V	+520		
pin 16	V_{16} *	V	+1060		
pin 17	V_{17} *	V	+1090		

Above measurements using circuits of Figs 3, 4a and 4b.

An alternative 3-diode modulator circuit is shown in Fig. 4c.

* D.C. component on these pulses is $V_{\text{B}'}$.

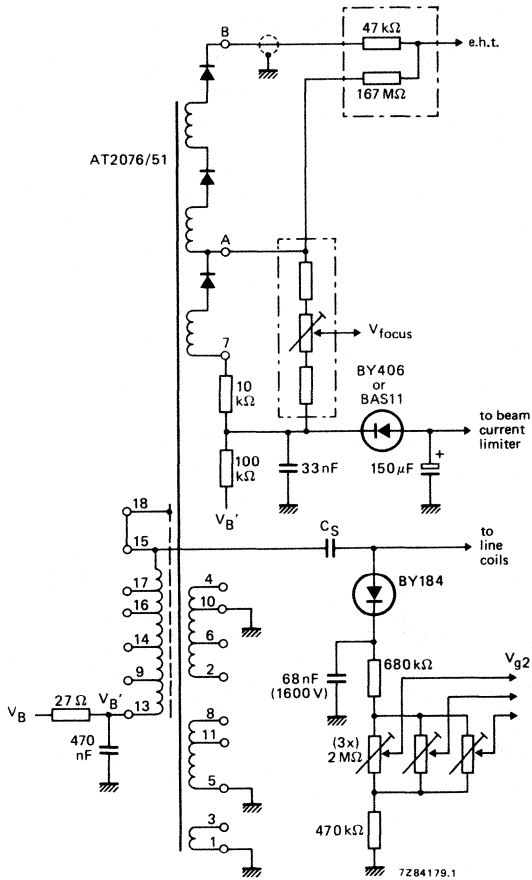

Fig. 3 Circuit diagram of transformer, and e.h.t., focus voltage and V_{g2} circuits.

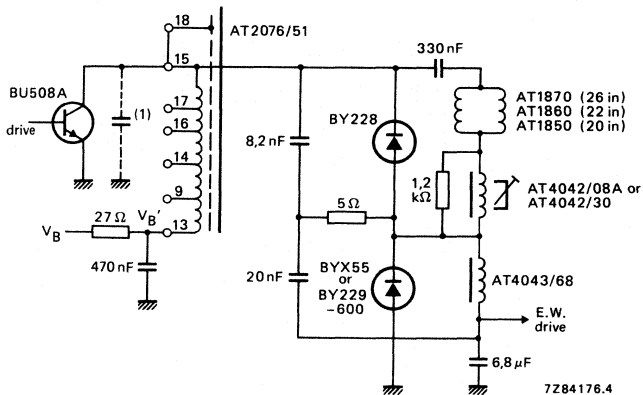

Fig. 4a Diode modulator with split tuning.

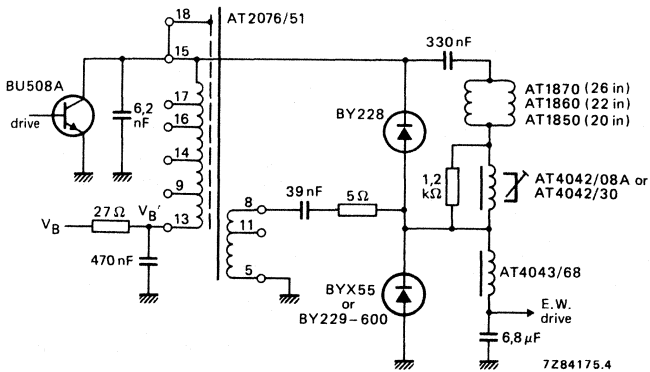

Fig. 4b Diode modulator with tap on transformer.

(1) Transformer stray capacitance.

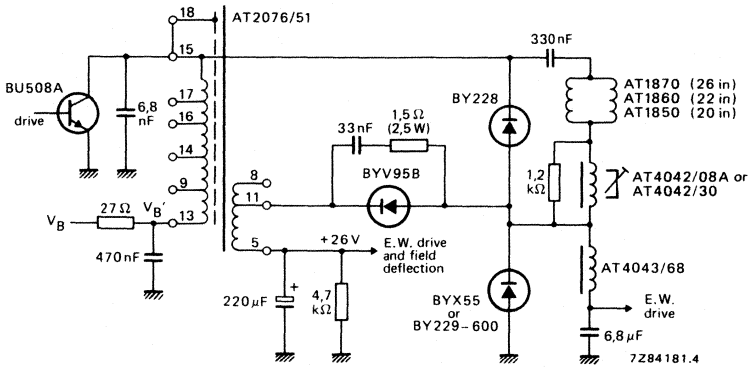

Fig. 4c Three-diode modulator circuit.

ELECTRICAL DATA with 90° COLOUR PICTURE TUBES.

			Figs 3 and 5a $V_B = 154,5 \text{ V}$		Figs 3 and 5b $V_B = 134,3 \text{ V}$	
E.H.T. supply	I_{eht}	mA	0,03	1	0,03	1
	e.h.t.	kV	24,55	22,1	25,0	22,5
	$R_{i(eht)}$	M Ω	-2,45-		-2,5-	
Power supply	$V_{B'}$	V	151,5	148,1	130,0	126,1
	$I_{average}$	mA	168	291	226	375
Output transistor	V_{CEM}	V	1220	1150	1060	995
	$+I_{CEM}$	A	2,0	2,1	2,4	2,5
Deflection	I_{p-p}	A	2,85	2,7	2,9	2,75
	$t_{flyback}$	μs	11,45		11,45	
	Overscan	%	6	7,5	6	7,5
V_{focus}		kV	8,45	7,7	8,6	7,8
Auxiliary windings:						
picture tube heater voltage V_{3-1} (r.m.s.)		V	9,13	8,7	9,30	8,79
peak voltages at						
pin 2	V_2	V	-275		-280	
pin 6	V_6	V	-146		-149	
pin 4	V_4	V	+62		+64	
pin 11	V_{11}	V	+223		+227	
pin 8	V_8	V	+322		+326	
pin 9	V_9^*	V	+112		+114	
pin 14	V_{14}^*	V	+515		+520	
pin 15	V_{15}^*	V			+1240	
pin 16	V_{16}^*	V	+1050			
pin 17	V_{17}^*	V	+1080		+1090	

Above measurements using circuits of Figs 3, 5a and 5b.

* D.C. component on these pulses is $V_{B'}$.

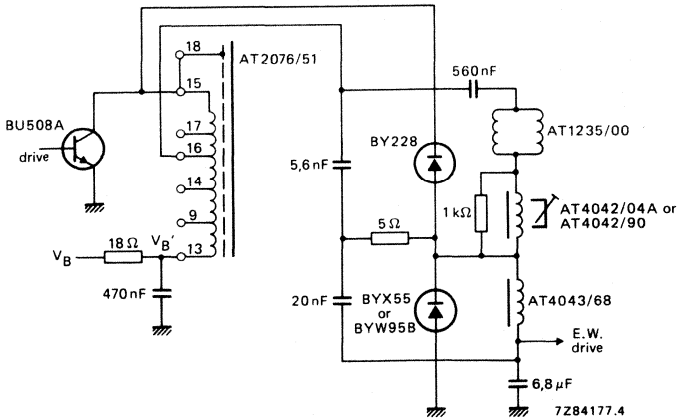

Fig. 5a Diode modulator, $V_B = 154,5 \text{ V}$.

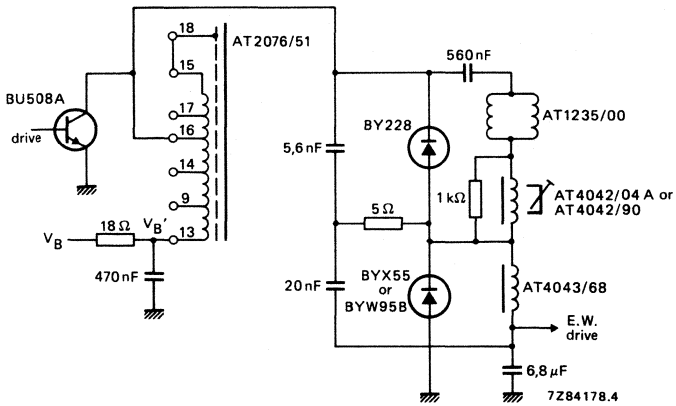

Fig. 5b Diode modulator, $V_B = 134,3 \text{ V}$.

Replaced by AT2076/84

DIODE-SPLIT LINE OUTPUT TRANSFORMER

- Three-layer e.h.t. coil
- Aluminium foil primary winding
- Piggy-back type
- For Data Graphic Displays.

QUICK REFERENCE DATA

For transistor line output stages

	deflection angle	110°	90°
I_{eht}		max. 1,5 mA	max. 1 mA
E.H.T.		25 kV	25 kV
$R_i(\text{eht})$		1,86 M Ω	2,45 M Ω
$I_{\text{p-p}}$ deflection (incl. 6% overscan)		5,3 A	2,85 A
Supply voltage ($V_{\text{B}'}$)		151 V	151,5 V
Supply current (I_{average}) at		477 mA ($I_{\text{eht}} = 1,5$ mA)	291 mA ($I_{\text{beam}} = 1$ mA)
Voltages of primary windings *		$V_{\text{p}} = +114, +520$ $+1060, +1090$	$+112, +515$ $+1050, +1080$
Voltages of auxiliary windings		$V_{\text{p}} = -280, -149, +64,$ $+227, +326$ picture tube heater voltage	$-275, -146, +62$ $+223, +322$

APPLICATION

This transformer has been designed to provide the required scanning amplitude for 110° and 90° colour picture tubes in transistor equipped receivers presenting 625 lines at 50 fields per second (CCIR) or 525 lines at 60 fields per second (USA).

It is intended for use in conjunction with:

	deflection angle	110°	90°
– deflection unit		AT1270/00, AT1260, AT1250	AT1235/00
– bridge coil		AT4043/68	AT4043/68
– linearity control unit		AT4042/08 or /30	AT4042/02 or /90
– line output transistor		BU508A	BU508A
– screened e.h.t. cable with a length of 1 m; catalogue number 3122 137 58254.			

DESCRIPTION

The magnetic circuit of the transformer comprises 2 Ferroxcube U-cores, screwed together. The primary winding of aluminium foil and the secondary windings are situated on one leg of the core. The e.h.t. winding is moulded in flame retarding polyester, meeting the self-extinguishing requirements of IEC65, para. 14.4 and UL492, para. 280-SE1. The transformer has 2 M3 screw-studs for mounting. ** External circuit connection is made to connecting pins, positioned as indicated in Fig. 1, enabling the unit to be soldered directly into a printed-wiring board (Fig. 2).

* D.C. component on these pulses is $V_{\text{B}'}$ (see Fig. 3).

** For mounting on the printed-wiring board a washer of 20 mm in diameter has to be used. Tightening torque on printed-wiring board: 500 + 100 mNm.

MECHANICAL DATA

Dimensions in mm

Outlines

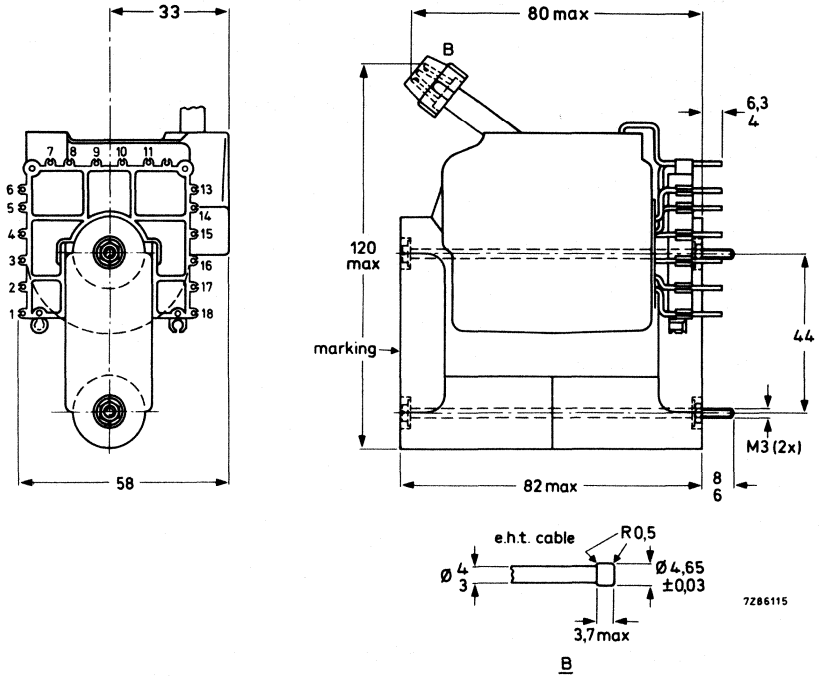

Fig. 1.

Solderability in accordance with IEC68, Test T

MOUNTING

The transformer may be mounted on either a printed-wiring board or, under certain conditions, on a metal chassis. Two securing studs (M3) are provided. The fit of the connecting and the mounting pins in a printed-wiring grid with a pitch of 2,54 mm is illustrated in Fig. 2.

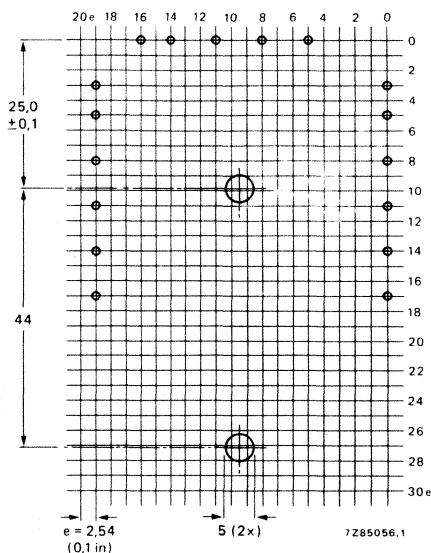

Fig. 2 Hole pattern for mounting on a printed-wiring board (solder side). Grid hole diameter 1,3 ± 0,1 mm.

Whether the transformer is board or chassis mounted, **the core must be earthed.**

Temperature

The operating temperature of the e.h.t. coil should not exceed + 85 °C under worst conditions, i.e. taking into account:

- over-voltage on the coils;
- low atmospheric pressure (at high altitudes) implying bad cooling by convection;
- high ambient temperature (up to 45 °C).

To satisfy this requirement it is recommended to provide sufficient flow of cool air around the transformer.

Distances

The following minimum distances between the transformer and neighbouring conductive flat surfaces must be maintained:

From the e.h.t. coil radially, 10 mm.

From the e.h.t. coil axially, 10 mm.

Sharp edges of conductive parts must have greater distances than given above.

The transformer, leads and components carrying high voltage pulses, should be kept free from metal particles, solder drops etc.

ELECTRICAL DATA with 110° COLOUR PICTURE TUBES

E.H.T. supply	I_{eht} e.h.t. $R_i(\text{eht})$	mA kV MΩ	0,03 25,0	1 23,2 -1,86-	1,5 22,2
Power supply	V_B	V	158,5	158,5	158,5
	$V_{B'}$	V	151	147,2	145,0
	I_{average}	mA	259	397	477
Output transistor	V_{CEM}	V	1240	1210	1190
	$+I_{\text{CEM}}$	A	3,5	3,6	3,65
Deflection	$I_{\text{p-p}}$	A	5,3	5,2	5,15
	t_{flyback}	μs	11,4	-	-
	Overscan	%	6	-	6,5
V_{focus}		kV	8,6	8,1	7,8
Auxiliary windings: picture tube heater voltage V_{3-1} (r.m.s.) peak voltages at		V	9,04	8,74	8,54
pin 2	V_2	V	-280		
pin 6	V_6	V	-149		
pin 4	V_4	V	+64		
pin 11	V_{11}	V	+227		
pin 8	V_8	V	+326		
pin 9	V_{g^*}	V	+114		
pin 14	V_{14^*}	V	+520		
pin 16	V_{16^*}	V	+1060		
pin 17	V_{17^*}	V	+1090		

Above measurements using circuits of Figs 3, 4a and 4b.

An alternative 3-diode modulator circuit is shown in Fig. 4c.

* D.C. component on these pulses is $V_{B'}$.

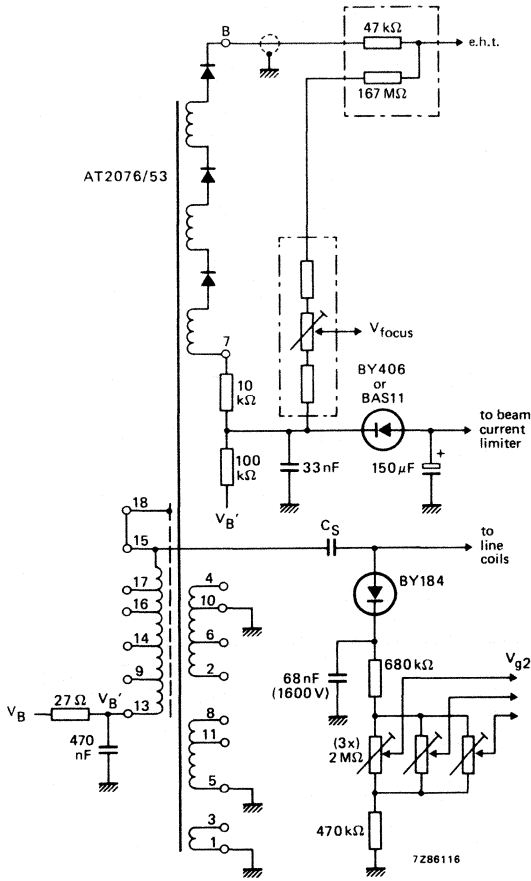

Fig. 3 Circuit diagram of transformer, and e.h.t., focus voltage and V_{g2} circuits.

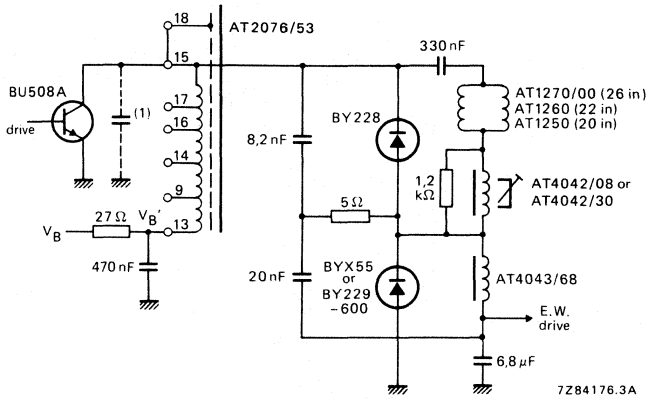

Fig. 4a Diode modulator with split tuning.

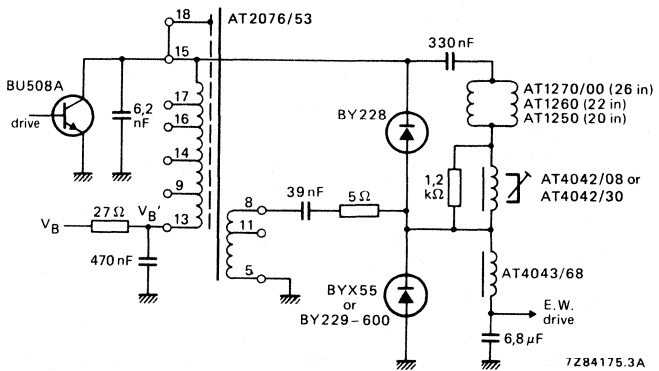

Fig. 4b Diode modulator with tap on transformer.

(1) Transformer stray capacitance.

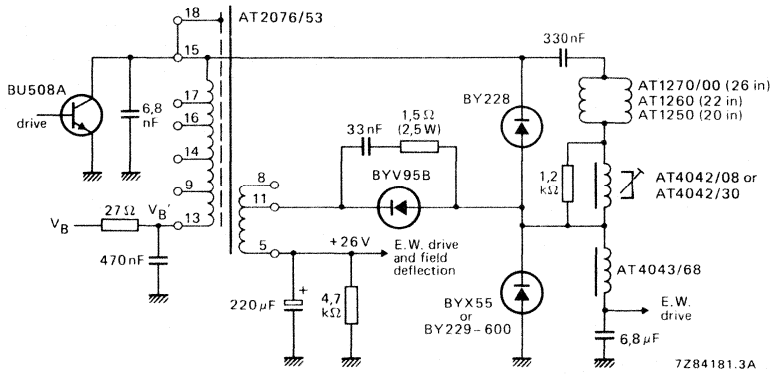

Fig. 4c Three-diode modulator circuit.

ELECTRICAL DATA with 90° COLOUR PICTURE TUBES

			Figs 3 and 5a $V_B = 154,5 \text{ V}$		Figs 3 and 5b $V_B = 134,3 \text{ V}$	
E.H.T. supply	I_{eht}	mA	0,03	1	0,03	1
	e.h.t. $R_{i(\text{eht})}$	kV M Ω	24,55 -2,45-	22,1	25,0 -2,5-	22,5
Power supply	$V_{B'}$	V	151,5	148,1	130,0	126,1
	I_{average}	mA	168	291	226	375
Output transistor	V_{CEM}	V	1220	1150	1060	995
	I_{CEM}	A	2,0	2,1	2,4	2,5
Deflection	$I_{\text{p-p}}$	A	2,85	2,7	2,9	2,75
	t_{flyback}	μs	11,45		11,45	
	Overscan	%	6	7,5	6	7,5
V_{focus}		kV	8,45	7,7	8,6	7,8
Auxiliary windings: picture tube heater voltage $V_{3.1}$ (r.m.s.)		V	9,13	8,7	9,30	8,79
peak voltages at						
pin 2	V_2	V	-275		-280	
pin 6	V_6	V	-146		-149	
pin 4	V_4	V	+62		+64	
pin 11	V_{11}	V	+223		+227	
pin 8	V_8	V	+322		+326	
pin 9	V_{9^*}	V	+112		+114	
pin 14	V_{14^*}	V	+515		+520	
pin 15	V_{15^*}	V			+1240	
pin 16	V_{16^*}	V	+1050			
pin 17	V_{17^*}	V	+1080		+1090	

Above measurements using circuits of Figs 3, 5a and 5b.

* D.C. component on these pulses is $V_{B'}$.

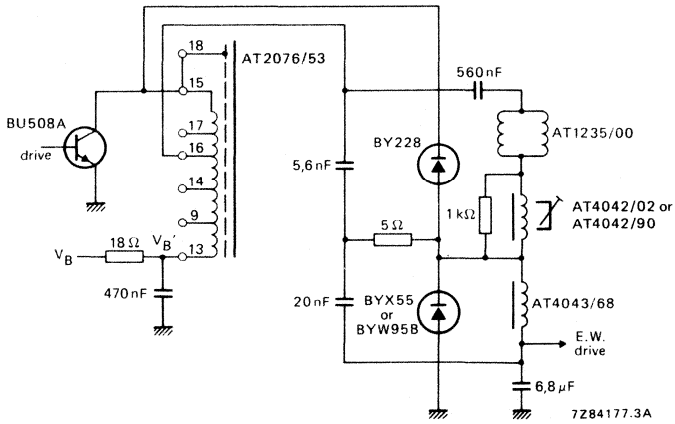

Fig. 5a Diode modulator, $V_B = 154,5\ \text{V}$.

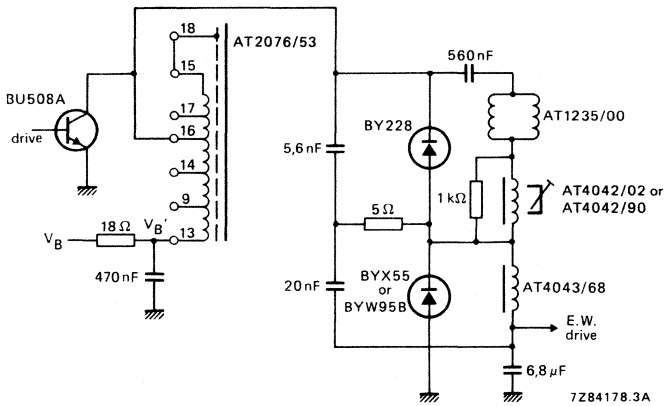

Fig. 5b Diode modulator, $V_B = 134,3\ \text{V}$.

UNIVERSAL DIODE-SPLIT LINE OUTPUT TRANSFORMER

- For monochrome Data Graphic Displays
- Three-layer e.h.t. coil
- Aluminium foil primary winding
- Piggy-back type

QUICK REFERENCE DATA

For transistor line output stages, deflection angle 110° , scan frequency 32 kHz.

I_{eht}	max. 0,5 mA
E.H.T.	17 kV
$R_i(\text{eht})$	1,3 M Ω
$I_{\text{p-p}}$ deflection	3,8 A
Supply voltage (V_B)	129 V
Supply current (I_{average})	210 mA
Flyback time	5,4 μs
Auxiliary voltages	+ 6 V, -6 V, + 11 V, + 26 V, + 41 V, + 52 V, -150 V, heater voltage 9,8 V(r.m.s.)

APPLICATION

This transformer has been designed to provide the required scanning amplitude for 38 cm (15 in)/ 110° monochrome data graphic display tubes, at line scan frequencies of 15,625 kHz, 32 kHz or 64 kHz.

It is intended for use in conjunction with:

- deflection unit AT1039/00 (for 'portrait' scan mode, scan frequency 64 kHz) or AT1039/01 (for 'landscape' scan mode, scan frequency 15,625 kHz or 32 kHz);
- line output transistor BU508A;
- screened e.h.t. cable, length 1 m, catalogue number 3122 137 58254.

DESCRIPTION

The magnetic circuit of the transformer comprises 2 Ferroxcube U-cores, screwed together. The primary winding of aluminium foil and the secondary windings are situated on one leg of the core. The e.h.t. winding is moulded in flame retarding polyester, meeting the self-extinguishing requirements of IEC 65, para. 14.4 and UL492, para. 280-SE1. The transformer has 2 M3 screw-studs for mounting.* External circuit connection is made to connecting pins, positioned as indicated in Fig. 1, enabling the unit to be soldered directly into a printed-wiring board (Fig. 2).

* For mounting on the printed-wiring board a washer of 20 mm in diameter has to be used. Tightening torque on printed-wiring board: 500 + 100 mNm.

MECHANICAL DATA

Dimensions in mm

Outlines

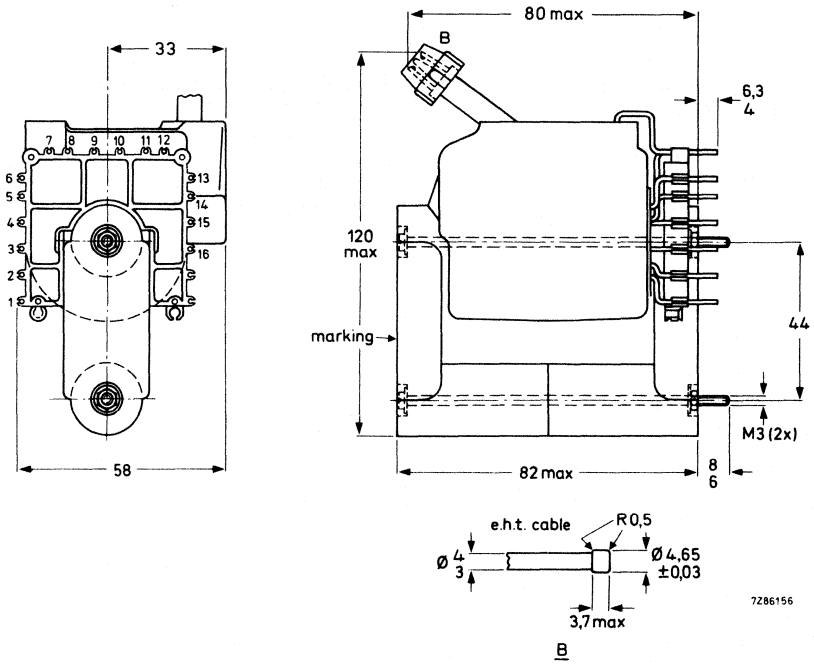

Fig. 1.

Mass approx. 500 g

Solderability in accordance with IEC 68, Test T

MOUNTING

The transformer may be mounted on either a printed-wiring board or, under certain conditions, on a metal chassis. Two securing studs (M3) are provided. The fit of the connecting and the mounting pins in a printed-wiring grid with a pitch of 2,54 mm is illustrated in Fig. 2.

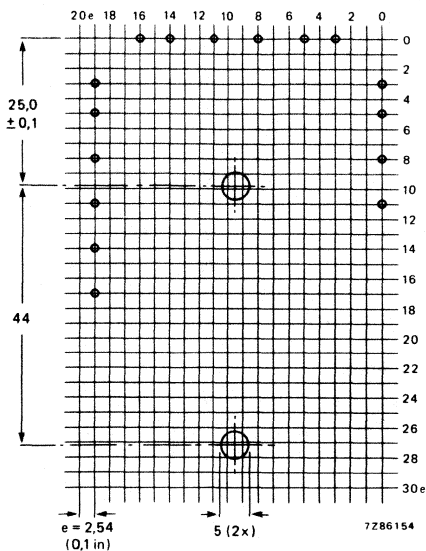

Fig. 2 Hole pattern for mounting on a printed-wiring board (solder side). Grid hole diameter $1,3 \pm 0,1$ mm.

Whether the transformer is board or chassis mounted, **the core must be earthed.**

Temperature

The operating temperature of the e.h.t. coil should not exceed + 85 °C under worst conditions, i.e. taking into account:

- over-voltage on the coils;
- low atmospheric pressure (at high altitudes) implying bad cooling by convection;
- high ambient temperature (up to 45 °C).

To satisfy this requirement it is recommended to provide sufficient flow of cool air around the transformer.

Distances

The following minimum distances between the transformer and neighbouring conductive flat surfaces must be maintained:

From the e.h.t. coil radially, 10 mm.

From the e.h.t. coil axially, 10 mm.

Sharp edges of conductive parts must have greater distances than given above.

The transformer, leads and components carrying high voltage pulses, should be kept free from metal particles, solder drops etc.

ELECTRICAL DATA

Scan frequency		Hz	15625 (Fig. 3)		31250 (Fig. 4)		62500 (Fig. 5)	
E.H.T. supply	I_{eht}	mA	0,035	0,55	0,035	0,55	0,035	0,55
	e.h.t.	kV	17,3	16,8	17,85	17,25	17,6	16,6
	$R_{i(\text{eht})}$	M Ω	1,1		1,3		2,0	
Power supply	$\left\{ \begin{array}{l} V_B \\ I_{\text{average}} \end{array} \right.$	V	68,5	68,5	129	129	100	100
		mA	385	530	210	285	310	410
Output transistor	V_{CEM}	V	560		1120		780	
Deflection	$\left\{ \begin{array}{l} I_{\text{p-p}} \\ I_{\text{flyback}} \end{array} \right.$	A	3,95	3,95	3,75	3,75	5,80	5,80
		μs	11,2	11,2	5,4	5,4	3,0	3,0
Tuning capacitor	C1	nF	20		2,2		1,6	
Auxiliary windings:								
heater voltage (r.m.s.)	V_{4-6}	V	9,53		9,83		9,92	
voltages (d.c.) * at								
pin 15 (V_{g2} , load 1M Ω)	V_{15}	V	+757		+842		+773	
pin 1 **	V_1	V	+49,7		+49,7		+55,4	
pin 3 **	V_3	V	+38,5		+38,5		+42,9	
pin 5 **	V_5	V	+24,5		+24,5		+27,3	
pin 2 (V_{g1} , load 10 k Ω)	V_2	V	-156		-166		-155	
pin 8 **	V_8	V	+10,5		+10,5		+11,8	
pin 11 **	V_{11}	V	+6,4		+6,4		+7,15	
pin 12 **	V_{12}	V	-6,4		-6,4		-7,15	

* Pins 9 and 10 connected to earth.

** Load 1 k Ω .

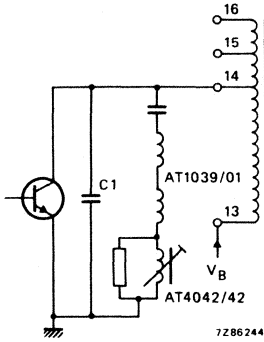

Fig. 3.

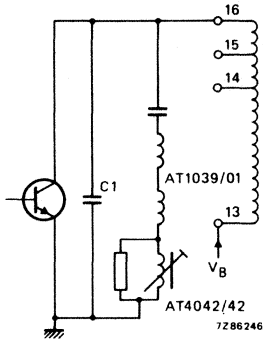

Fig. 4.

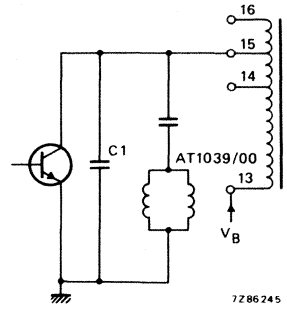

Fig. 5.

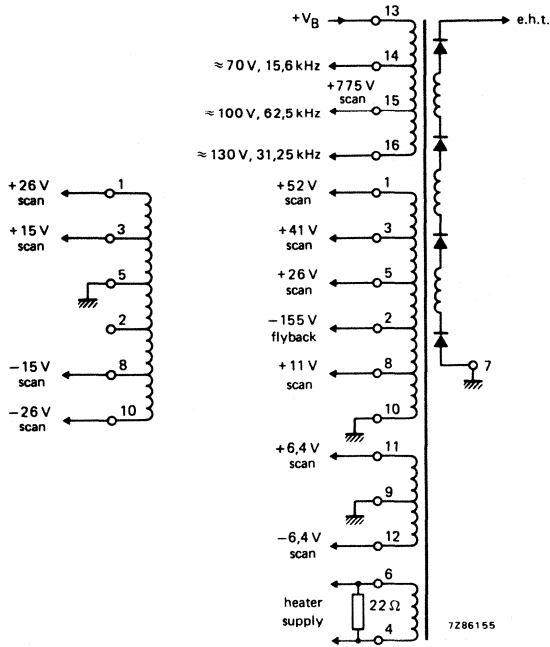

Fig. 6 Application circuit.

ASYNCHRONOUS POWER PACK TRANSFORMER

- For colour Data Graphic Displays
- Mains isolation
- Aluminium foil primary winding and screens

QUICK REFERENCE DATA

E.H.T.	25 kV
I_{eht}	max. 1,6 mA
$R_{i(\text{eht})}$	1 M Ω
Supply voltage (d.c.)	+300 V
current ($I_{\text{eht}} = 1,5 \text{ mA}$)	400 mA
Voltages of auxiliary windings	-9 V, +20 V, +31 V, +42 V, +150 V, +200 V, +225 V

APPLICATION

This transformer has been designed for use as a mains isolated supply transformer in colour monitors. It provides the required stabilized auxiliary voltages including an e.h.t. supply with low internal resistance. The transformer is suitable for 90° and 110° deflection systems using 25 kV e.h.t. It is intended for use in conjunction with:

- mains filter choke AT4043/55;
- mains transformer TS561/2;
- line driver transformer AT4043/87;

and for 110° tubes:

- deflection unit AT1870; AT1860 and AT1850;
- line choke AT4043/53;
- linearity control unit AT4042/08A;
- line driver transformer AT4043/87 (if separate drive of line output stage is required);

and for 90° tubes:

- deflection unit AT1235/00;
- line choke AT4043/53;
- linearity control unit AT4042/04A;

DESCRIPTION

The magnetic circuit of the transformer comprises two Ferroxcube U-cores screwed together. The primary winding of aluminium foil with screens and the e.h.t. winding with incorporated diodes are moulded in flame retarding polyester.

The device is provided with two securing M3 studs. External circuit connection is made to connecting pins, positioned as indicated in Fig. 1, enabling the unit to be soldered directly into a printed-wiring board (Fig. 3).

MECHANICAL DATA

Dimensions in mm

Outlines

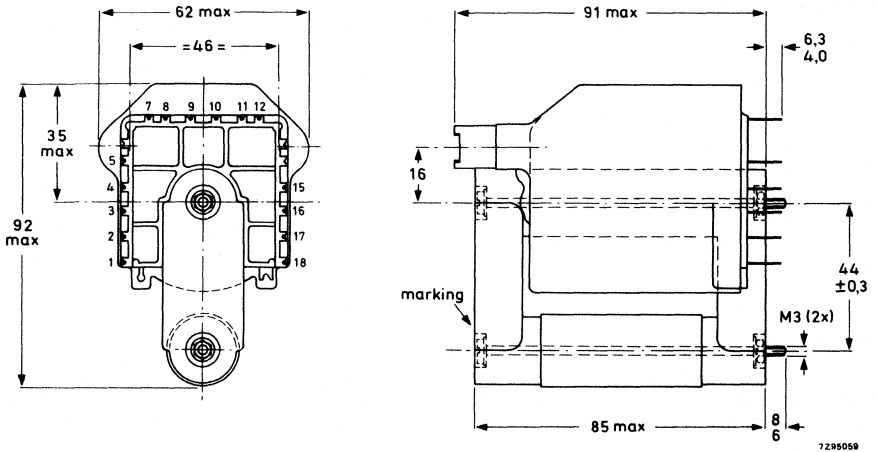

Fig. 1 Transformer AT2076/60.

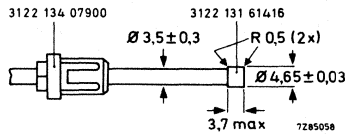

Fig. 2 Plug for connection to e.h.t.

Mass 530 g

Solderability max. 240 °C, max. 2,5 s

Mounting

The transformer may be mounted on either a printed-wiring board or on a metal chassis. Two securing studs (M3) are provided. For mounting on a printed-wiring board, a washer of 20 mm outer diameter has to be used; the tightening torque on the printed-wiring board is $500 + 100$ mNm. The fit of the connecting pins and the studs in a printed-wiring grid with a pitch of 2,54 mm is illustrated in Fig. 3.

Whether the transformer is board or chassis mounted, *the core must be earthed.*

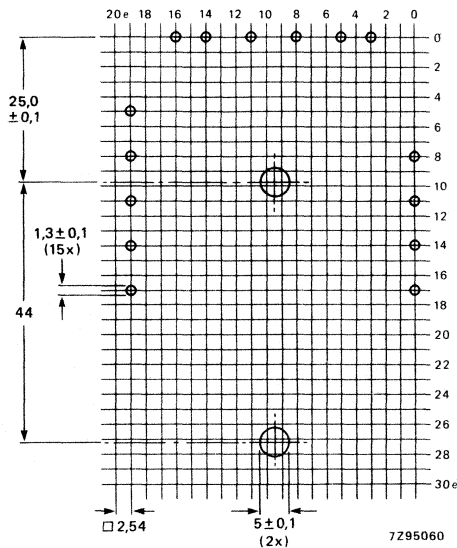

Fig. 3 Hole pattern for mounting on a printed-wiring board (solder side).

Temperature

The ambient temperature in the set should not exceed $+65$ °C under worst conditions, i.e. taking into account:

- maximum output power;
- maximum supply voltage;
- low atmospheric pressure (at high altitudes) implying bad cooling by convection;
- high ambient temperature (up to 45 °C).

To satisfy this requirement it may be necessary to provide an ample cool air flow around the transformer.

Distances

The following minimum distances between the transformer and neighbouring conductive flat surfaces must be maintained (it should be noted that edges of conductive parts must have a greater distance):

from the e.h.t. coil, radially 10 mm, axially 10 mm.

The transformer, and the leads and components carrying high voltage pulses, should be kept free from metal particles, solder drops etc.

ELECTRICAL DATA (measured in circuit of Fig. 4, mains voltage 220 V)

E.H.T. supply	I_{eht} e.h.t. $R_i(\text{eht})$	mA kV M Ω	0,1 25 0,9	1,6 23,7
Power supply	V_B^*	V	300	297
	I_{average}	mA	270	390
Supply transistor (BU208A)	V_{CEM} $+ I_{\text{CM}}$	V A	1000 1,9	1000 2,5
Flyback time		μs	9,5	10,5
Auxiliary windings (typical values **):				
picture tube heater voltage	V_1	V	-9 (6,5 W)	
drive winding	V_{15-16}	V	+100	
field time base	V_9	V	+42 (13 W)	
line time base	V_{10}	V	+150 (20 W)	
	V_4	V	+200 (22 W)	
video output	V_8	V	+225 (9 W)	
audio output	V_2	V	+31 (5 W)	
small signal output	V	V	+20 (10 W)	

* Stabilization range V_B from 215 V d.c. (165 V mains) to 350 V d.c. (265 V mains).

** Values apply to voltages after rectification, and pins 3, 11 and 12 connected to earth.

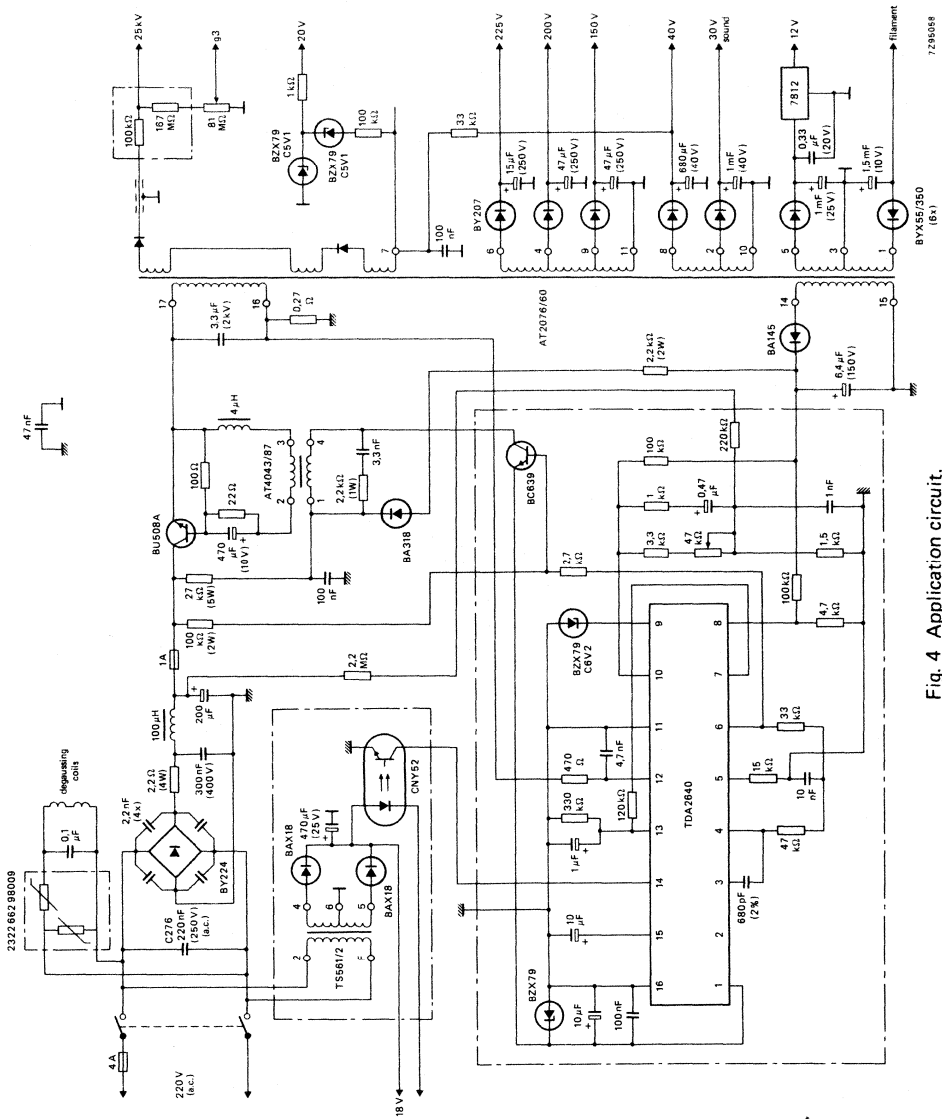

Fig. 4 Application circuit.

SYNCHRONOUS POWER PACK TRANSFORMER

for colour television

- Piggy-back type
- Mains isolation
- Aluminium foil primary winding and screens

QUICK REFERENCE DATA

E.H.T.	25 kV \pm 3%
I_{eht}	max. 1,6 mA
$R_{i(\text{eht})}$	1 M Ω
V_x (see Fig. 3)	6,25 kV \pm 3%
Supply	
voltage d.c.	+ 295 V
current ($I_{\text{eht}} = 1,6$ mA)	450 mA
Voltages of auxiliary windings	
r.m.s.	4,3 V, 8 V
d.c.	7,5 V, 18 V, 25 V, 33 V, 150 V, 205 V

APPLICATION

This transformer has been designed for use as a mains isolated supply transformer in colour television sets. It provides the required stabilized auxiliary voltages including an e.h.t. supply with low internal resistance. The transformer is suitable for 90° and 110° deflection systems using 25 kV e.h.t. It is intended for use in conjunction with:

- mains filter choke AT4043/55;
- mains transformer TS561/2;
- current sensing transformer AT4043/46;
- driver transformer AT4043/45;
- supply choke AT4043/52;

and for 110° 20, 22 and 26 inch tubes:

- deflection unit AT1870, AT1860, and AT1850;
- line choke AT4043/53;
- linearity control unit AT4042/08A or AT4042/30;
- line driver transformer AT4043/87 (if separate drive of line output stage is required);

and for 90° 20 inch tubes:

- deflection unit AT1235/00;
- line choke AT4043/53;
- linearity control unit AT4042/04A or AT4042/90.

DESCRIPTION

The magnetic circuit of the transformer comprises two Ferroxcube U-cores screwed together. The primary winding of aluminium foil with screens and the e.h.t. winding with incorporated diodes are moulded in flame retarding polyester.

The device is provided with two securing M3 studs. External circuit connection is made to connecting pins, positioned as indicated in Fig. 1, enabling the unit to be soldered directly into a printed-wiring board (Fig. 2).

MECHANICAL DATA

Dimensions in mm

Outlines

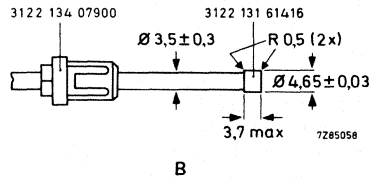
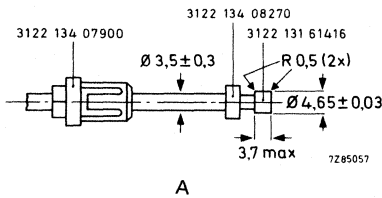
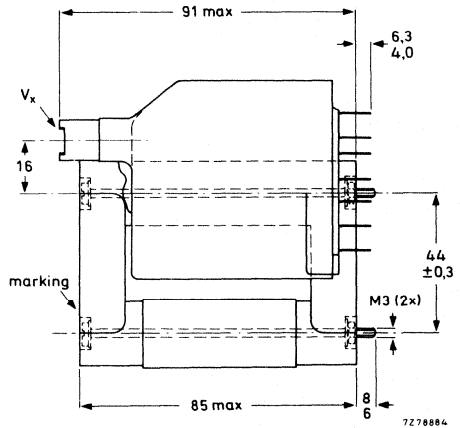
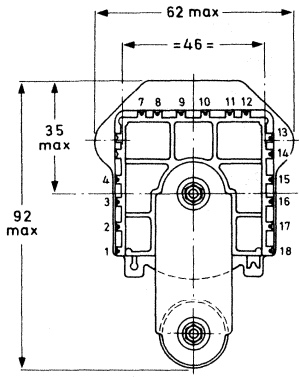

Fig. 1 A is plug for connection to V_x , B is plug for connection to e.h.t.

Mass 540 g

Solderability max. 240 °C, max. 2,5 s

Mounting

The transformer may be mounted on either a printed-wiring board or, on a metal chassis. Two securing studs (M3) are provided. For mounting on a printed-wiring board, a washer of 20 mm outer diameter has to be used. Tightening torque on printed-wiring board 500 ± 100 mNm. The fit of the connecting pins and the studs in a printed-wiring grid with a pitch of 2,54 mm is illustrated in Fig. 2.

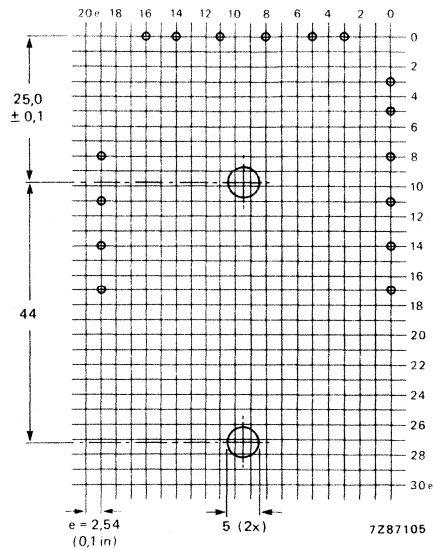

Fig. 2 Hole pattern for mounting on a printed-wiring board (solder side). Grid hole diameter $1,3 \pm 0,1$ mm.

Whether the transformer is board or chassis mounted, the core must be earthed.

Temperature

The ambient temperature in the set should not exceed $+65$ °C under worst conditions, i.e. taking into account:

- maximum output power;
- maximum supply voltage;
- low atmospheric pressure (at high altitudes) implying bad cooling by convection;
- high ambient temperature (up to 45 °C).

To satisfy this requirement it may be necessary to provide an ample cool air flow around the transformer.

Distances

The following minimum distances between the transformer and neighbouring **conductive flat surfaces** must be maintained (it should be noted that edges of conductive parts must have a greater distance):

from the e.h.t. coil, radially 10 mm, axially 10 mm.

The transformer, and the leads and components carrying high voltage pulses, should be kept free from metal particles, solder drops etc.

ELECTRICAL DATA (measured in circuit of Fig. 3, mains voltage 220 V)

E.H.T. supply	I_{eht} e.h.t. $R_{i(\text{eht})}$	mA kV M Ω	0,15 25,2 1,0	1,6 23,7
Power supply	V_B * I_{average}	V mA	297 230	292 450
$V_{O \text{ prim}}$		V	150	150,5
Supply transistor (BU208A)	V_{CEM} $+ I_{\text{CM}}$	V A	1250 2,8	1260 3,1
Flyback time		μs	14,8	15,0
V_x		kV	6,25	—
Auxiliary windings (typical value):				
picture tube heater voltage	V_{18} (r.m.s.)	V	8,0 (730 mA)	
drive winding	V_{15-17} (r.m.s.)	V	4,3 (1 A)	
Voltages after rectification, pins 10 and 11 to earth:				
field time base	V_8	V	33 (325 mA)	
line time base	V_9	V	150 (125 mA)	
	V_{12}	V	7,5 (1000 mA)	
video output	V_{13}	V	205 (10 mA)	
audio output	V_{14}	V	24,6 (500 mA)	
audio output	V_{16}	V	17,8 (530 mA)	

Note: The power pack is capable of supplying 45 W extra output power if required, e.g. higher audio output power from pin 14.

* Stabilization range V_B from 215 V d.c. (165 V mains) to 350 V d.c. (265 V mains).

APPLICATION CIRCUIT

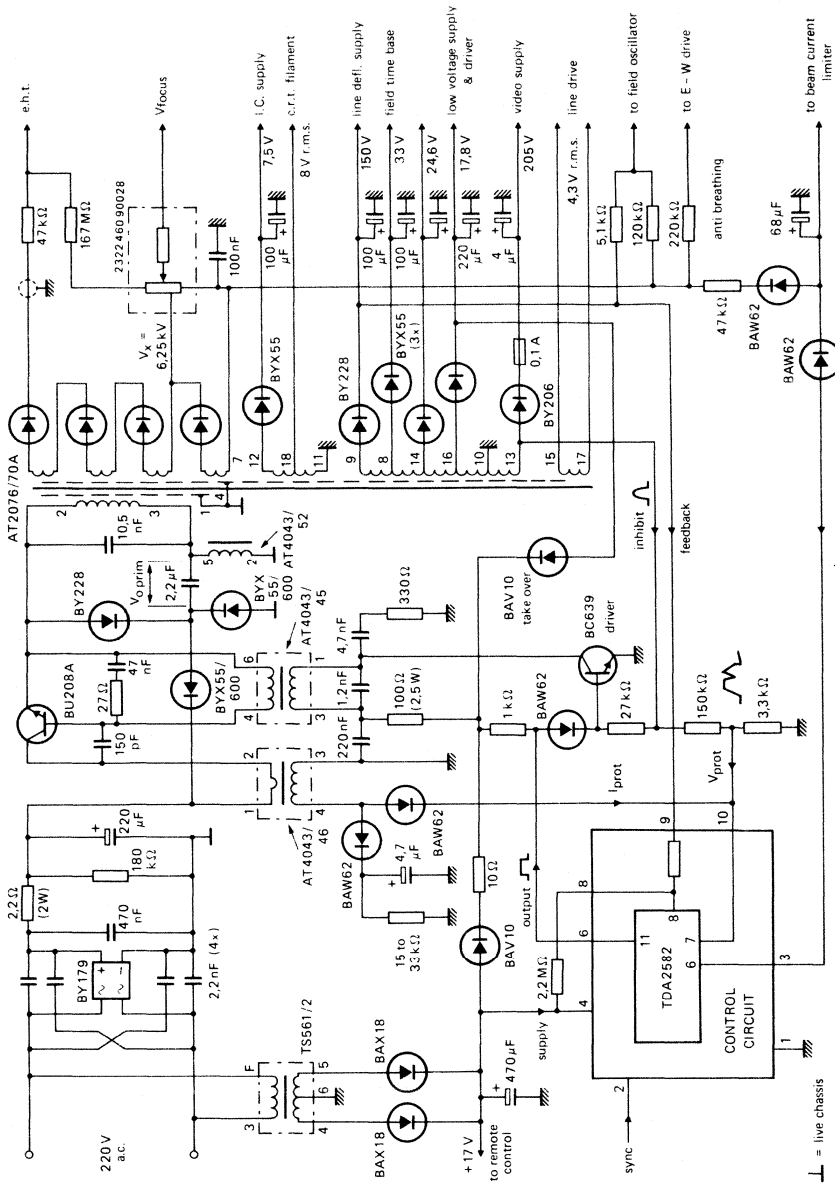

Fig. 3.

⊥ = live chassis
 ≡ = mains isolated chassis

MINIATURE DIODE-SPLIT LINE OUTPUT TRANSFORMER

- For 90° colour TV and colour monitors
- Three-layer e.h.t. coil, focus tap for hi-bi
- Aluminium foil primary winding
- Simplified synchronous power pack system
- Raster correction free

QUICK REFERENCE DATA

For transistor line output stages; 90° deflection angle

I_{eht}	0 mA	0,6 mA	
E.H.T.	23,0 kV	21,2 kV	
$R_i(\text{eht})$		2,6 M Ω	
$I_{\text{p-p}}$ deflection	3,2 A	3,12 A	
Supply voltage (V_B)	111 V	109,6 V	
Supply current (I_{average})	350 mA	460 mA	
Auxiliary voltages	7,9 V(r.m.s.), -210 V(p-p), +28 V(p-p),	-500 V(p-p), -124 V(p-p), +210 V(p-p),	-420 V(p-p), -14 V(p-p), +440 V(p-p)

APPLICATION

This transformer has been designed to provide the required scanning amplitude for 90° colour picture tubes in transistor or gate turn-off thyristor equipped television receivers presenting 625 lines at 50 fields per second (CCIR) or 525 lines at 60 fields per second (USA). The transformer may also be used in colour monitors.

It is intended for use in conjunction with:

- deflection unit AT1206/20, AT1216/20 or AT1236/20,
- input choke AT4043/81;
- driver transformer AT4043/82;
- sensing transformer AT4043/46;
- line output transistor BU508A;
- screened e.h.t. cable, length 1 m; catalogue number 3122 137 63370;
- focus cable, length 31 cm; catalogue number 3122 131 00732.

Note: Types AT2076/80 and AT2076/80A differ only in manufacturing technique; apart from this the transformers are identical.

DESCRIPTION

The magnetic circuit of the transformer comprises 2 Ferroxcube U-cores, screwed together. The primary winding of aluminium foil and the secondary windings are situated on one leg of the core. The primary winding together with its e.h.t. winding are moulded in flame retarding polyester, meeting the self-extinguishing requirements of IEC 65, para. 14.4 and UL492, para. 280-SE1. The transformer has 2 M3 screw-studs for mounting. External circuit connection is made to connecting pins, positioned as indicated in Fig. 1, enabling the unit to be soldered directly into a printed-wiring board (Fig. 2).

MECHANICAL DATA

Dimensions in mm

Outlines

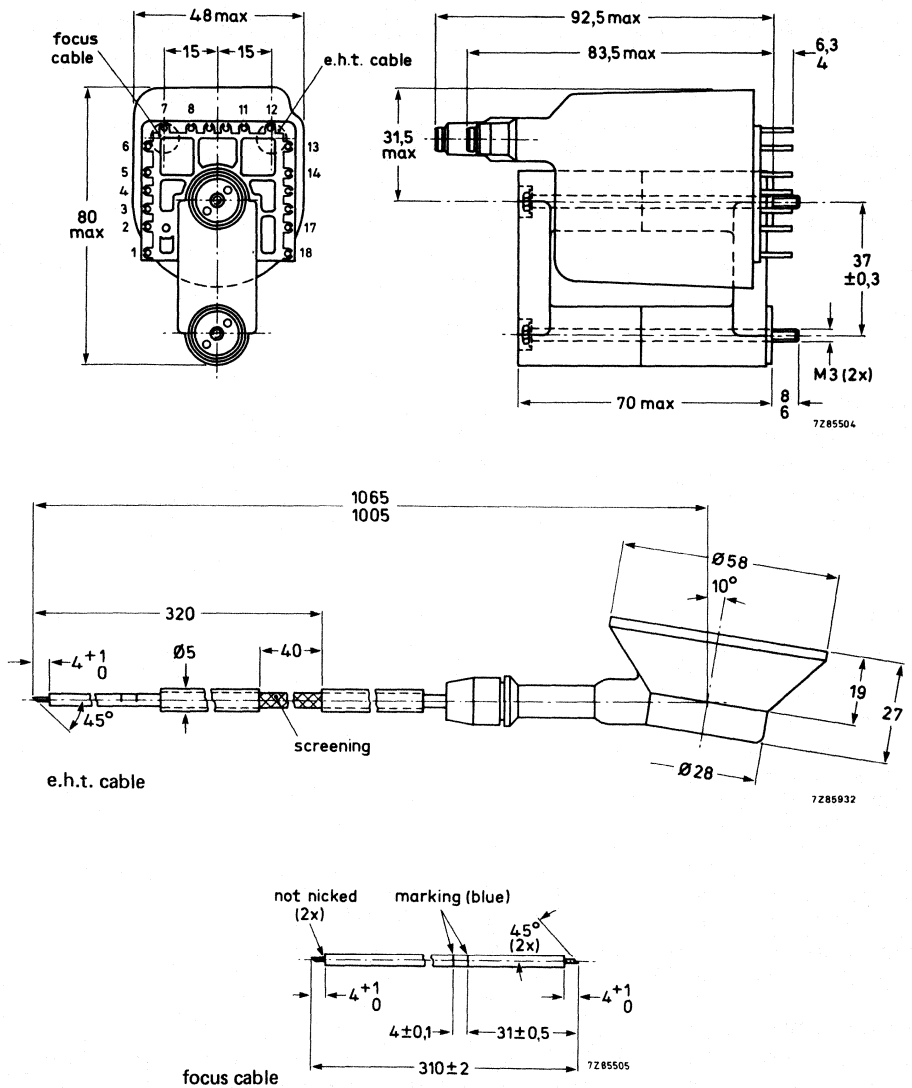

Fig. 1.

Mass 325 g

Solderability in accordance with IEC 68, test T

Mounting

The transformer may be mounted on either a printed-wiring board or, under certain conditions, on a metal chassis. Two securing studs (M3) are provided. For mounting on a printed-wiring board a washer of 20 mm outer diameter has to be used; the tightening torque on the printed-wiring board is $500 + 100$ mNm. The fit of the connecting pins and the studs in a printed-wiring grid with a pitch of 2,54 mm is illustrated in Fig. 2.

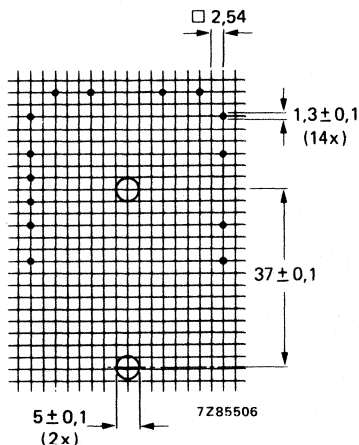

Fig. 2 Hole pattern for mounting on a printed-wiring board (solder side).

Whether the transformer is board or chassis mounted, **the core must be earthed.**

Temperature

The operating temperature of the e.h.t. coil should not exceed $+ 85$ °C under worst conditions, i.e. taking into account:

- over-voltage on the coils;
- low atmospheric pressure (at high altitudes) implying bad cooling by convection;
- high ambient temperature (up to 45 °C).

To satisfy this requirement it is recommended to provide sufficient flow of cool air around the transformer.

Distances

The following minimum distances between the transformer and neighbouring conductive flat surfaces must be maintained:

From the e.h.t. coil radially, 10 mm

From the e.h.t. coil axially, 10 mm

Sharp edges of conductive parts must have greater distances than given above.

The transformer, leads and components carrying high voltage pulses, should be kept free from metal particles, solder drops, etc.

ELECTRICAL DATA with 90° COLOUR PICTURE TUBES

E.H.T. supply	I_{eht} e.h.t. $R_{\text{i(eht)}}$	mA kV MΩ	0 23,0 2,6	0,6 21,2
Power supply	V_{B} I_{average}	V mA	111 350	109,6 460
Output transistor	V_{CEM} + I_{CEM}	V A	1285 2,95	1280 2,95
Deflection	$I_{\text{p-p}}$ t_{flyback} Overscan	A μs %	3,2 12,0 6	3,12 12,0 —
V_{focus}		kV	7,65	7,05
Auxiliary windings:				
picture tube heater voltage (r.m.s. value)		V	7,97	7,72
Voltages (peak-to-peak values) at				
pin 1	V_1	V	+440	
pin 17	V_{17}	V	-420	
pin 6	V_6	V	-500	
pin 2	V_2	V	-210	
pin 5	V_5	V	-124	
pin 8	V_8	V	+28	
pin 4	V_4	V	+210	
pin 14	V_{14}	V	-14	

Above measurements using circuit of Fig. 3.

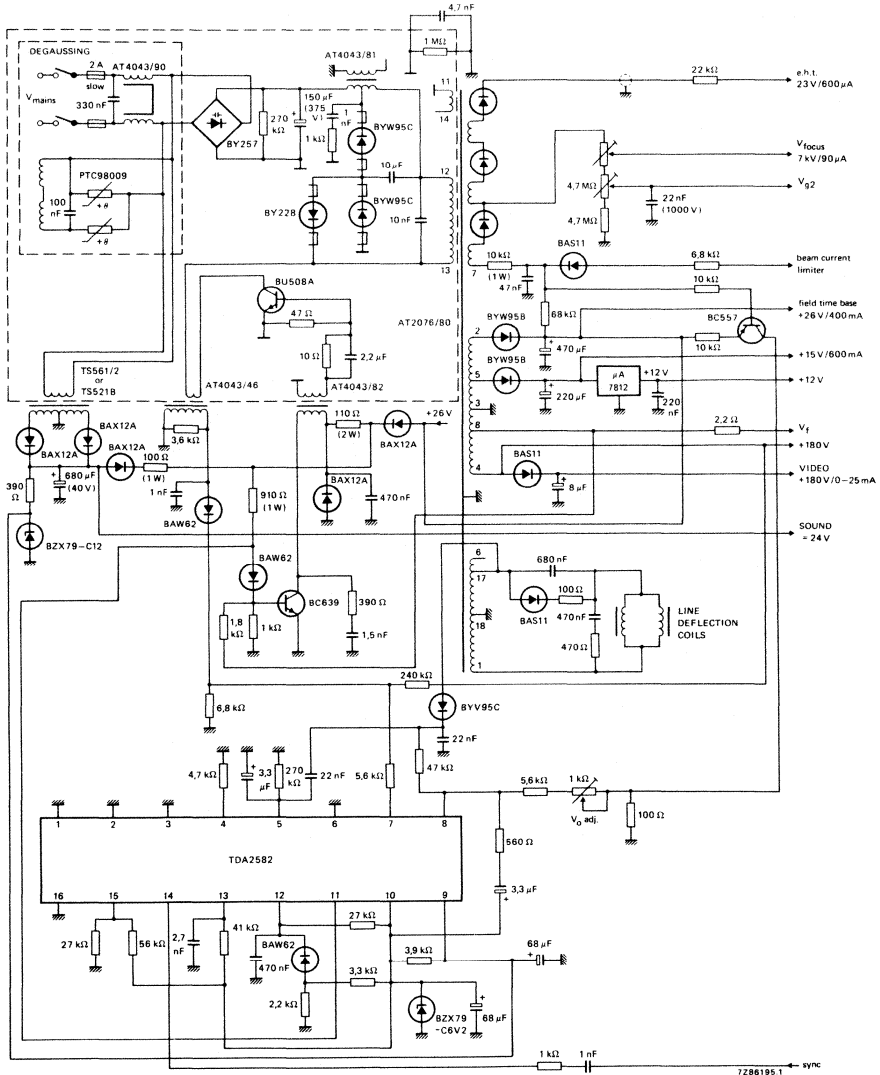

Fig. 3 Application circuit.

MINIATURE DIODE-SPLIT LINE OUTPUT TRANSFORMER

- For 90° and 110° colour TV and colour monitors
- Three-layer e.h.t. coil, focus tap for hi-bi
- Aluminium foil primary winding
- Reduced dimensions, reduced mass

QUICK REFERENCE DATA

For transistor line output stages

	110° deflection angle	90° deflection angle
I_{eht}	max. 1,5 mA	max. 1 mA
E.H.T.	25 kV	25 kV
$R_{i(eht)}$	1,6 M Ω	2,9 M Ω
I_{p-p} deflection (incl. 6% overscan)	5,3 A	2,85 A
Supply voltage ($V_{B'}$)	150 V	148,1 V
Supply current ($I_{average}$)	466 mA	299 mA
Voltages of primary windings*	+ 98 V_p , + 530 V_p , + 960 V_p , + 1060 V_p	+ 100 V_p , + 514 V_p , + 930 V_p , + 1030 V_p , + 1190 V_p
Voltages of auxiliary windings	-290 V_p , -230 V_p , -148 V_p , + 62 V_p , + 105 V_p	-270 V_p , -222 V_p , -141 V_p , + 60 V_p , + 105 V_p

picture tube heater voltage

APPLICATION

This transformer has been designed to provide the required scanning amplitude for 110° and 90° colour picture tubes in transistor or gate turn-off thyristor equipped television receivers presenting 625 lines at 50 fields per second (CCIR) or 525 lines at 60 fields per second (USA). The transformer may also be used in colour monitors and monochrome monitors at 17 kV e.h.t.

It is intended for use in conjunction with:

	110° deflection angle	90° deflection angle
- deflection unit	AT1870, AT1860, AT1850	AT1235/00, AT1235/40
- bridge coil	AT4043/68	AT4043/68
- linearity control unit	AT4042/08A, AT4042/30	AT4042/04A, AT4042/90
- line output transistor	BU508A	BU508A
- screened e.h.t. cable, length 1 m; catalogue number 3122 137 63370.		
- focus cable, length 31 cm; catalogue number 3122 131 00732.		

Note: Types AT2076/81 and AT2076/81A differ only in manufacturing technique; apart from this the transformers are identical.

DESCRIPTION

The magnetic circuit of the transformer comprises 2 Ferroxcube U-cores, screwed together. The primary winding of aluminium foil and the secondary windings are situated on one leg of the core. The primary winding together with its e.h.t. winding are moulded in flame retarding polyester, meeting the self-extinguishing requirements of IEC65, para. 14.4 and UL492, para. 280-SE1. The transformer has 2 M3 screw-studs for mounting. External circuit connection is made to connecting pins, positioned as indicated in Fig. 1, enabling the unit to be soldered directly into a printed-wiring board (Fig. 2).

* D.C. component on these pulses is $V_{B'}$ (see Fig. 3).

MECHANICAL DATA

Dimensions in mm

Outlines

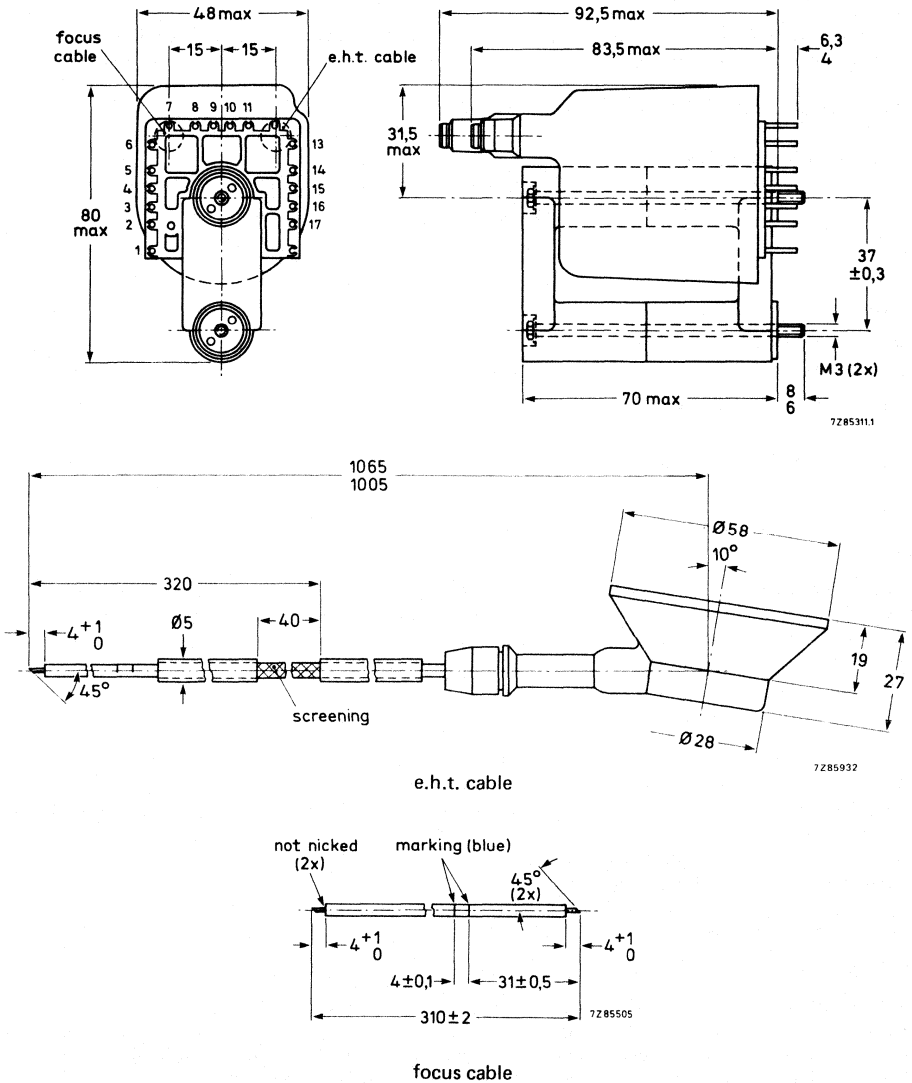

Fig. 1.

Mass 325 g

Solderability in accordance with IEC 68, test T

Mounting

The transformer may be mounted on either a printed-wiring board or, under certain conditions, on a metal chassis. Two securing studs (M3) are provided. For mounting on a printed-wiring board a washer of 20 mm outer diameter has to be used; the tightening torque on the printed-wiring board is $500 + 100$ mNm. The fit of the connecting pins and the studs in a printed-wiring grid with a pitch of 2,54 mm is illustrated in Fig. 2.

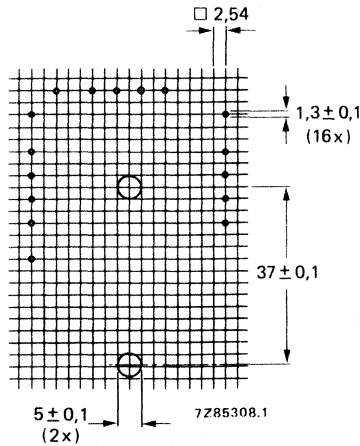

Fig. 2 Hole pattern for mounting on a printed-wiring board (solder side).

Whether the transformer is board or chassis mounted, **the core must be earthed.**

Temperature

The operating temperature of the e.h.t. coil should not exceed $+ 85$ °C under worst conditions, i.e. taking into account:

- over-voltage on the coils;
- low atmospheric pressure (at high altitudes) implying bad cooling by convection;
- high ambient temperature (up to 45 °C).

To satisfy this requirement it is recommended to provide sufficient flow of cool air around the transformer.

Distances

The following minimum distances between the transformer and **neighbouring conductive flat surfaces** must be maintained:

From the e.h.t. coil radially, 10 mm

From the e.h.t. coil axially, 10 mm

Sharp edges of conductive parts must have greater distances than given above.

The transformer, leads and components carrying high voltage pulses, should be kept free from metal particles, solder drops, etc.

ELECTRICAL DATA with 110° COLOUR PICTURE TUBES

E.H.T. supply	I_{eht} e.h.t. $R_{i(eht)}$	mA kV MΩ	0,03 25,0 1,6	1 23,4 1,6	1,5 22,6 1,6
Power supply	V_B $V_{B'}$ $I_{average}$	V	157,8	157,8	157,8
		V	150,2	145,7	143,3
		mA	242	393	466
Output transistor	V_{CEM} $+ I_{CEM}$	V	1240	1220	1200
		A	3,6	3,7	3,7
Deflection	I_{p-p} $t_{flyback}$ Overscan	A	5,3	5,1	5,0
		μs	11,4	—	—
		%	6	—	—
V_{focus}		kV	8,1	7,9	7,8
Auxiliary windings: picture tube heater voltage V_{3-1} (r.m.s.) peak voltages at		V	8,3	8,0	7,8
pin 2	V_2	V	-290		
pin 6	V_6	V	-148		
pin 4	V_4	V	+ 62		
pin 5	V_5	V	-230		
pin 8	V_8	V	+ 105		
pin 9	V_9^*	V	+ 98		
pin 14	V_{14}^*	V	+ 530		
pin 17	V_{17}^*	V	+ 960		
pin 16	V_{16}^*	V	+ 1060		

Above measurements using circuits of Figs 3, 4a and 4b.

An alternative 3-diode modulator circuit is shown in Fig. 4c.

* D.C. component on these pulses is $V_{B'}$.

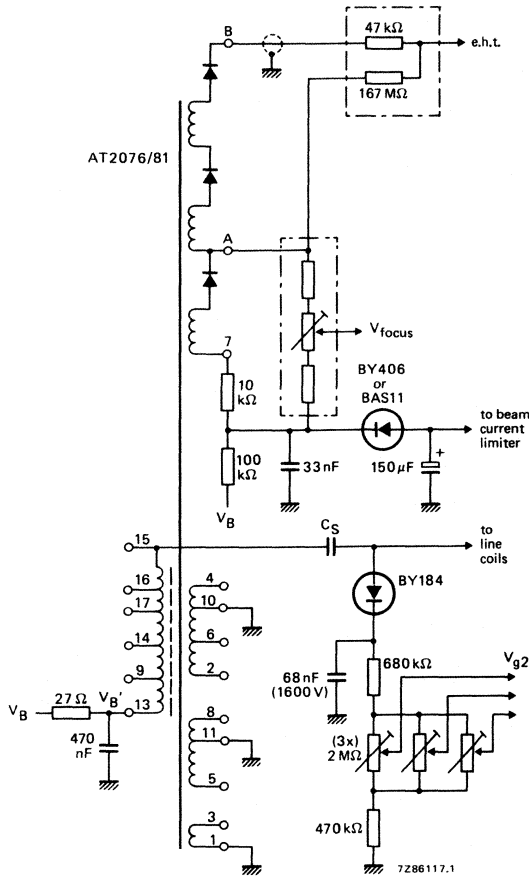

Fig. 3 Circuit diagram of transformer, and e.h.t., focus voltage and V_{g2} circuits.

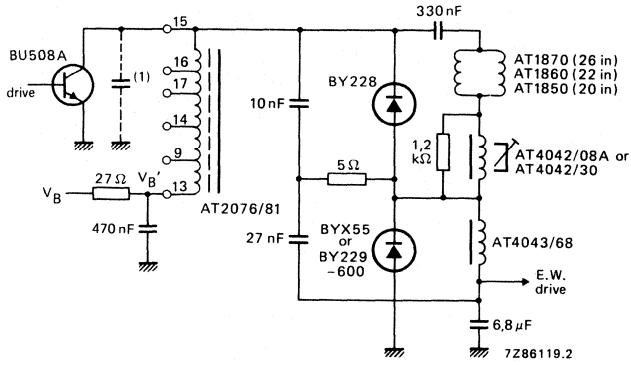

Fig. 4a Diode modulator with split tuning.

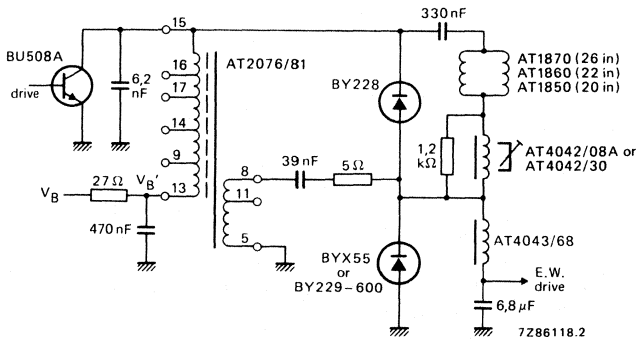

Fig. 4b Diode modulator with tap on transformer.

(1) Transformer stray capacitance.

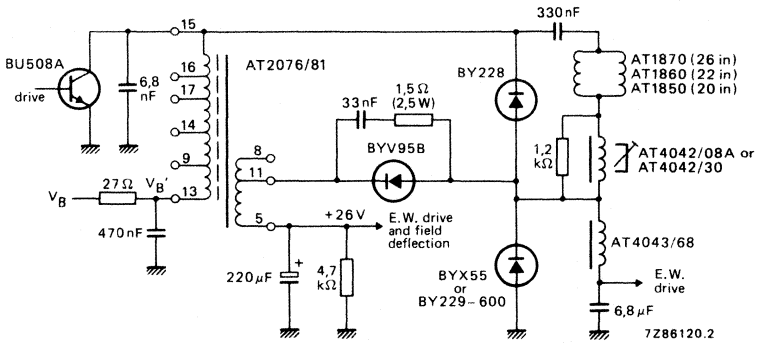

Fig. 4c Three-diode modulator circuit.

ELECTRICAL DATA with 90° COLOUR PICTURE TUBES

		Figs 3 and 5a $V_B = 154,5 \text{ V}$		Figs 3 and 5b $V_B = 134,3 \text{ V}$		
E.H.T. supply	I_{eht}	mA	0,03	1	0,03	1
	e.h.t.	kV	25,0	22,1	25,0	22,0
	$R_{i(eht)}$	M Ω	2,9		3	
Power supply	$V_{B'}$	V	151,5	148,1	130,0	126,1
	$I_{average}$	mA	173	299	245	389
Output transistor	V_{CEM}	V	1220	1150	1060	995
	$+ I_{CEM}$	A	2,0	2,2	2,4	2,6
Deflection	I_{p-p}	A	2,90	2,78	2,92	2,89
	$t_{flyback}$	μs	11,45		11,45	
	Overscan	%	6	7,0	6	7,0
V_{focus}		kV	8,45	7,40	8,6	7,65
Auxiliary windings: picture tube heater voltage V_{3-1} (r.m.s.) peak voltages at		V	8,11		8,15	
pin 2	V_2	V	-270		-274	
pin 6	V_6	V	-141		-144	
pin 4	V_4	V	+ 60		+61	
pin 5	V_5	V	-222		-225	
pin 8	V_8	V	+ 105		+ 105	
pin 9	V_9^*	V	+ 100		+ 102	
pin 14	V_{14}^*	V	+ 514		+ 520	
pin 15	V_{15}^*	V	+ 1190		+ 1200	
pin 16	V_{16}^*	V	+ 1030		+ 1040	
pin 17	V_{17}^*	V	+ 930		+ 940	

Above measurements using circuits of Figs 3, 5a and 5b.

* D.C. component on these pulses is $V_{B'}$.

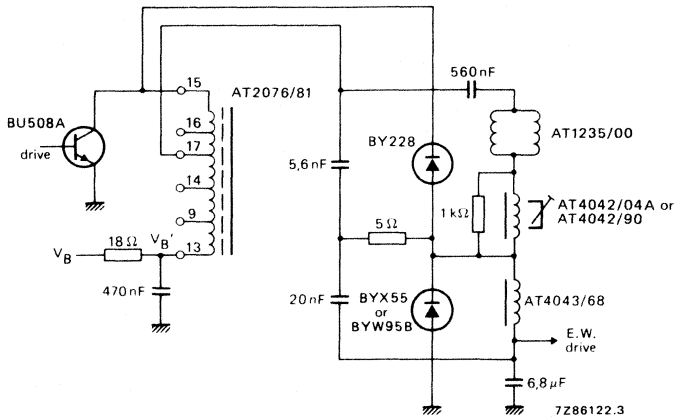

Fig. 5a Diode modulator, $V_{B'} = 150$ V.

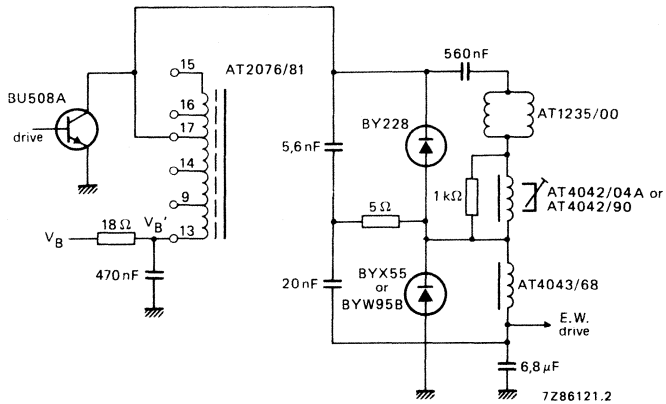

Fig. 5b Diode modulator, $V_{B'} = 130$ V.

UNIVERSAL DIODE-SPLIT LINE OUTPUT TRANSFORMER

- For monochrome Data Graphic Displays
- Three-layer e.h.t. coil
- Aluminium foil primary winding
- Piggy-back type

QUICK REFERENCE DATA

For transistor line output stages, deflection angle 110°

	landscape	portrait
$I_{e.h.t.}$	max. 0,5 mA	
E.H.T. at $I_B = 0$ mA	17 kV	
$R_i(e.h.t.)$	1,2 M Ω	
Flyback time	4 to 9 μ s	3 to 8 μ s
Line scan frequency range	15 to 50 kHz	15 to 70 kHz
Primary voltages	+ 94 V _(p-p) , + 188 V _(p-p) , + 540 V _(p-p) , + 730 V _(p-p) , + 990 V _(p-p)	
Auxiliary voltages	+ 85 V _p , -85 V _p , + 24 V _p , + 55 V _p , -150 V _p , heater voltage	

APPLICATION

This transformer has been designed to provide the required scanning amplitude and e.h.t. for 110° monochrome data graphic display tubes, at line scan frequencies of 15 to 70 kHz in both landscape and portrait scan mode. A choice can be made from different flyback times.

The transformer is intended for use in conjunction with:

- deflection unit AT1039 series at line scan frequencies of 15 to 70 kHz (portrait scan mode) or of 15 to 50 kHz (landscape scan mode);
- line output transistor BUW12A;
- linearity control unit AT4042/08A or AT4042/33A
- screened e.h.t. cable, length 1 m; catalogue number 3122 137 63370.

DESCRIPTION

The magnetic circuit of the transformer comprises 2 Ferroxcube U-cores, screwed together. The primary winding of aluminium foil and the secondary windings are situated on one leg of the core. The transformer is moulded in flame retarding polyester, meeting the self-extinguishing requirements of IEC 65, para. 14.4 and UL492, para. 280-SE1. The transformer has 2 M3 screw-studs for mounting. External circuit connection is made to connecting pins, positioned as indicated in Fig. 1, enabling the unit to be soldered directly into a printed-wiring board (Fig. 3).

MECHANICAL DATA

Dimensions in mm

Outlines

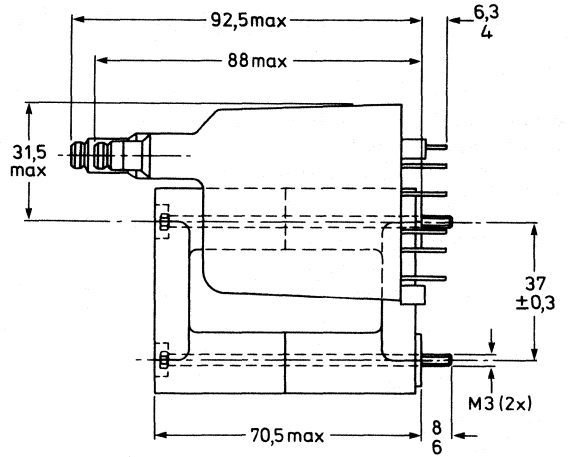
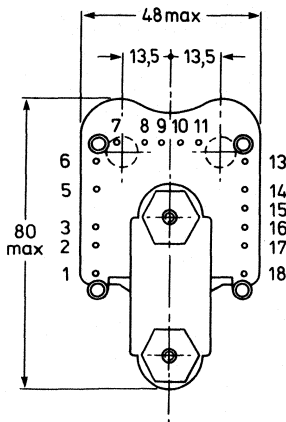

Fig. 1 Line output transformer AT2076/84.

7291248.1

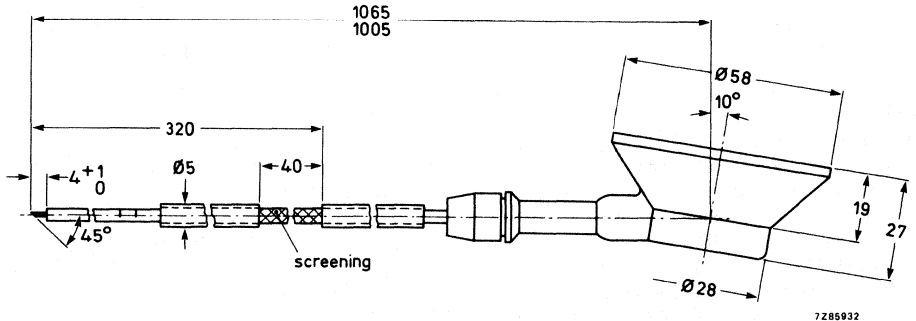

Fig. 2 E.H.T. cable 3122 137 63370.

7285932

Mass approx. 325 g

Solderability in accordance with IEC 68-2-20, test Ta.

Mounting

The transformer may be mounted on either a printed-wiring board or, under certain conditions, on a metal chassis. Two securing studs (M3) are provided. For mounting on a printed-wiring board a washer of 20 mm outer diameter has to be used; the tightening torque on the printed-wiring board is 500 + 100 mNm. The fit of the connecting pins and the studs in a printed-wiring grid with a pitch of 2,54 mm is illustrated in Fig. 3.

Whether the transformer is board or chassis mounted, **the core must be earthed.**

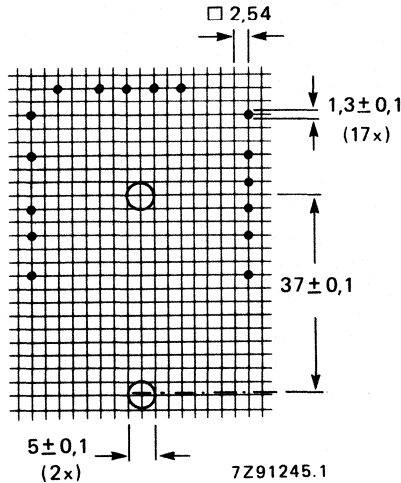

Fig. 3 Hole pattern for mounting on a printed-wiring board (solder side).

Temperature

The operating temperature of the e.h.t. coil should not exceed + 65 °C under worst conditions, i.e. taking into account:

- over-voltage on the coils;
- low atmospheric pressure (at high altitudes) implying bad cooling by convection;
- high ambient temperature (up to 45 °C).

To satisfy this requirement it is recommended to provide sufficient flow of cool air around the transformer.

Distances

The following minimum distances between the transformer and neighbouring conductive flat surfaces must be maintained:

- From the e.h.t. coil radially, 10 mm.
- From the e.h.t. coil axially, 10 mm.

Sharp edges of conductive parts must have greater distances than given above.

The transformer, leads and components carrying high voltage pulses, should be kept free from metal particles, solder drops etc.

ELECTRICAL DATA (see also Figs 4 and 5)**Landscape scan mode**

Line scan frequency range

15 to 50 kHz

	line deflection coils parallel connected			line deflection coils series connected		
	13/17	14/17	15/17	15/18	13/17	14/17
Taps of primary winding to be used	13/17	14/17	15/17	15/18	13/17	14/17
Flyback time	4,0 μ s	4,8 μ s	5,9 μ s	7,0 μ s	8,0 μ s	9,0 μ s
Flyback capacitor (C1)	7,5 nF	10 nF	18 nF	7,5 nF	10 nF	15 nF
Deflection current	8,4 A _(p-p)	8,4 A _(p-p)	8,4 A _(p-p)	4,2 A _(p-p)	4,2 A _(p-p)	4,2 A _(p-p)
Deflection voltage	730 V _(p-p)	630 V _(p-p)	540 V _(p-p)	800 V _(p-p)	730 V _(p-p)	630 V _(p-p)

Portrait scan mode

Line scan frequency range

15 to 70 kHz

	line deflection coils parallel connected			line deflection coils series connected		
	13/17	14/17	15/17	15/18	13/17	14/17
Taps of primary winding to be used	13/17	14/17	15/17	15/18	13/17	14/17
Flyback time	3,1 μ s	4,2 μ s	4,9 μ s	5,9 μ s	6,6 μ s	7,9 μ s
Flyback capacitor (C1)	3,3 nF	6,8 nF	10 nF	4,7 nF	5,6 nF	10 nF
Deflection current	6,2 A _(p-p)	6,2 A _(p-p)	6,2 A _(p-p)	3,1 A _(p-p)	3,1 A _(p-p)	3,1 A _(p-p)
Deflection voltage	730 V _(p-p)	630 V _(p-p)	540 V _(p-p)	800 V _(p-p)	730 V _(p-p)	630 V _(p-p)

Primary voltages (peak-to-peak values)

Pins 13/14	+ 94 V
Pins 13/15	+ 188 V
Pins 13/16	+ 540 V
Pins 13/17	+ 730 V
Pins 13/18	+ 990 V

Auxiliary voltages (peak values)

Pins 5/8	heater voltage
Pin 1	+ 55 V (video supply)
Pin 2	- 150 V (V_{g1})
Pin 3	+ 24 V (field time base)
Pin 10	- 85 V
Pin 11	+ 85 V

V_{g2} -circuit supply should be taken from pin 17 or 18 by means of peak rectification.

Note: For detailed information see Technical Publication 115.

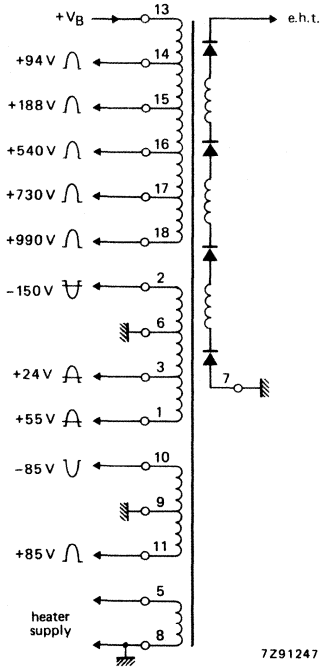

Fig. 4.

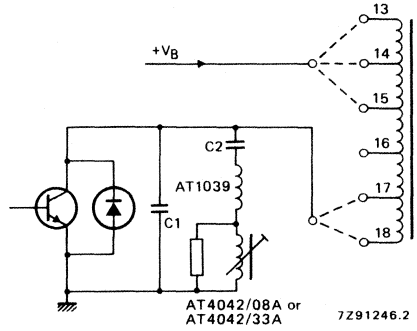

Fig. 5.

DIODE-SPLIT-BOX LINE OUTPUT TRANSFORMER

- For 90° colour TV with single switch power pack system (S²P²)
- Three-layer e.h.t. coil
- Aluminium foil primary winding
- Incorporated potentiometers for focusing and V_{g2} adjustment
- Mains insulation

QUICK REFERENCE DATA

For transistor line output stages; 90° deflection angle

I _{eht}	0 mA
E.H.T.	23 kV
R _i (eht)	≤ 2,4 MΩ
I _{p-p} deflection	3,0 A
Supply voltage (V _B)	112 V
Supply current at I _{eht} = 0,6 mA	460 mA
Focusing voltage control	5,1 to 7,6 kV
Grid 2 voltage adjustment	230 to 830 V
Auxiliary voltages	6,3 V (heater supply) 200 V (video supply) 26 V (frame) 16 V (small signal)

APPLICATION

This transformer has been designed to provide the required scanning amplitude for 90° colour picture tubes in transistor equipped television receivers presenting 625 lines at 50 fields per second (CCIR) or 525 lines at 60 fields per second (USA). The transformer may also be used in colour monitors.

It is intended for use in conjunction with:

- input choke AT4043/81;
- driver transformer AT4043/82;
- sensing transformer AT4043/46;
- mains transformer TS561/2 or TS521B;
- mains filter choke AT4043/90;
- linearity corrector AT4042/90 (for narrow neck tubes), or AT4042/91 (for mini neck tubes);
- screened e.h.t. cable, length 1 m; catalogue number 3122 137 63370;
- focus cable, length 31 cm; catalogue number 3122 131 00732.

DESCRIPTION

The magnetic circuit of the transformer comprises 2 Ferroxcube cores, glued together. The primary winding of aluminium foil and the secondary windings are situated on one leg of the core. The primary winding together with its e.h.t. winding and e.h.t. diodes are encapsulated with epoxy resin in a pre-moulded case. The transformer has potentiometers for focusing control and V_{g2} adjustment. The transformer case has 3 holes that enables fixing to a printed-wiring board with self-tapping screws. External circuit connection is made to connecting pins, positioned as indicated in Fig. 1, enabling the unit to be soldered directly into a printed-wiring board (Fig. 4).

MECHANICAL DATA
Outlines

Dimensions in mm

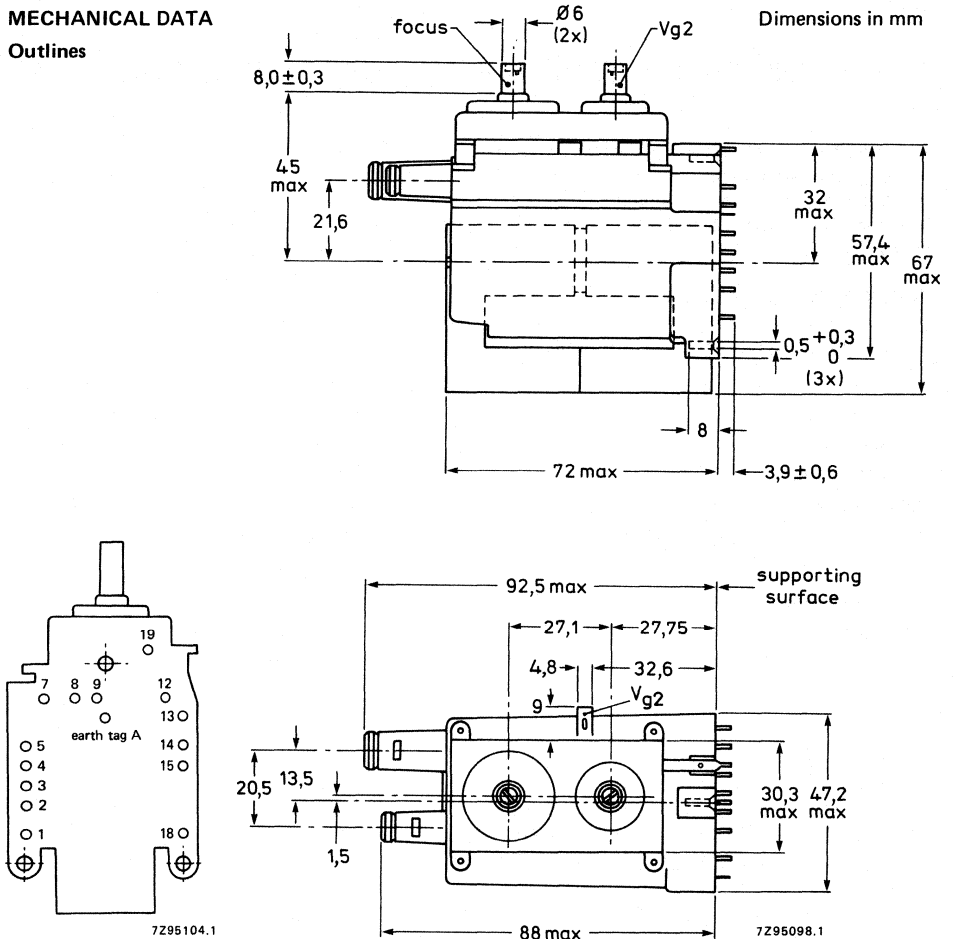

Fig. 1 Line output transformer AT2077/80.

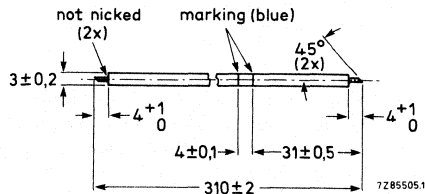

Fig. 2 Focus cable 3122 131 00732.

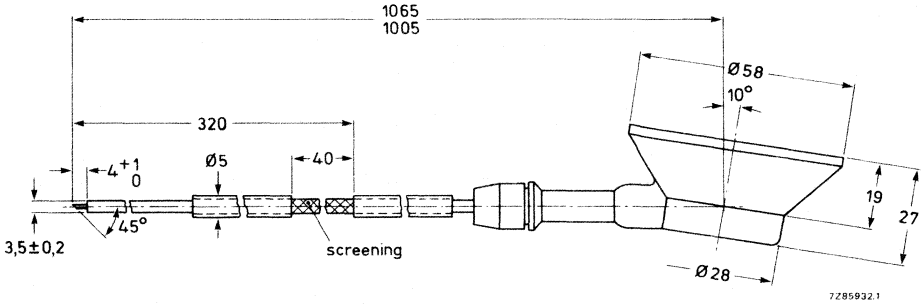

Fig. 3 E.H.T. cable 3122 137 63370.

- Mass** approx. 375 g
- Solderability** in accordance with IEC 68, test T
- Packing** 27 transformers per box
- Mounting**

The transformer may be mounted on a printed-wiring board. It can be secured with 3 self-tapping screws; the tightening torque on the board is $500 + 300$ mNm. The fit of the connecting pins in a printed-wiring grid with a pitch of 2,54 mm is illustrated in Fig. 4. The transformer core must be earthed via the earth tag (see Fig. 1).

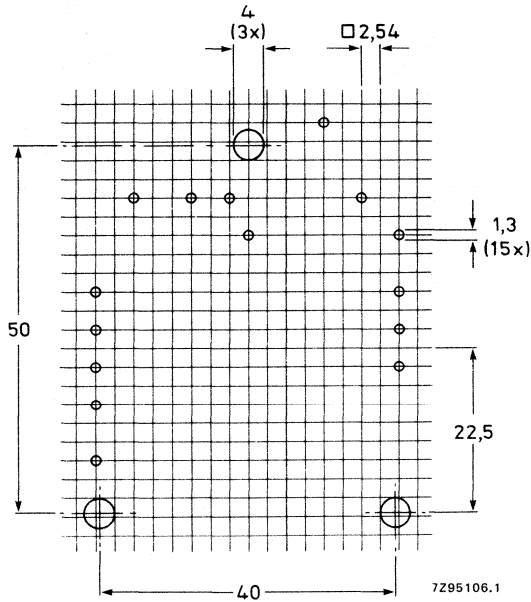

Fig. 4 Hole pattern for mounting on a printed-wiring board (solder side).

Temperature

The operating temperature of the e.h.t. coil should not exceed + 60 °C under worst conditions, i.e. taking into account:

- over-voltage on the coils;
- low atmospheric pressure (at high altitudes) implying bad cooling by convection;
- high ambient temperature (up to 45 °C).

To satisfy this requirement it is recommended to provide sufficient flow of cool air around the transformer.

Distances

The following minimum distances between the transformer and neighbouring conductive flat surfaces must be maintained:

- From the e.h.t. coil radially, 10 mm
- From the e.h.t. coil axially, 10 mm

Sharp edges of conductive parts must have greater distances than given above.

The transformer leads and components carrying high-voltage pulses, should be kept free from metal particles, solder drops, etc.

ELECTRICAL DATA with 90° colour picture tubes

E.H.T. supply	I_{eht} $e.h.t.$ $R_{\text{i}}(eht)$	mA kV M Ω	0 23,0	0,1 22,4 2,4	0,6 21,2
Power supply	V_{B} I_{average}	V mA	112 350		108,5 460
Output transistor	V_{CEM} $+ I_{\text{CEM}}$	V A	1285 2,55		1270 2,60
Deflection	deflection current flyback time overscan	A(p-p) μs %	3,0 11,95 6		2,88 11,95
Focusing voltage	min. max.	kV kV	5,1 7,6		
Grid 2 voltage (V_{g2})	min. max.	V V	230 830		
Auxiliary voltages*	heater voltage pin 2 pin 3 pin 4 pin 5 pin 8 pin 9 pin 12	V(r.m.s.) V(p-p) V(p-p) V(p-p) V(p-p) V(p-p) V(p-p) V(p-p) V(p-p)	8,0 + 190 -208 + 27,5 -138 + 845 + 920 + 70		7,7

* Pins 1 and 18 connected to earth.

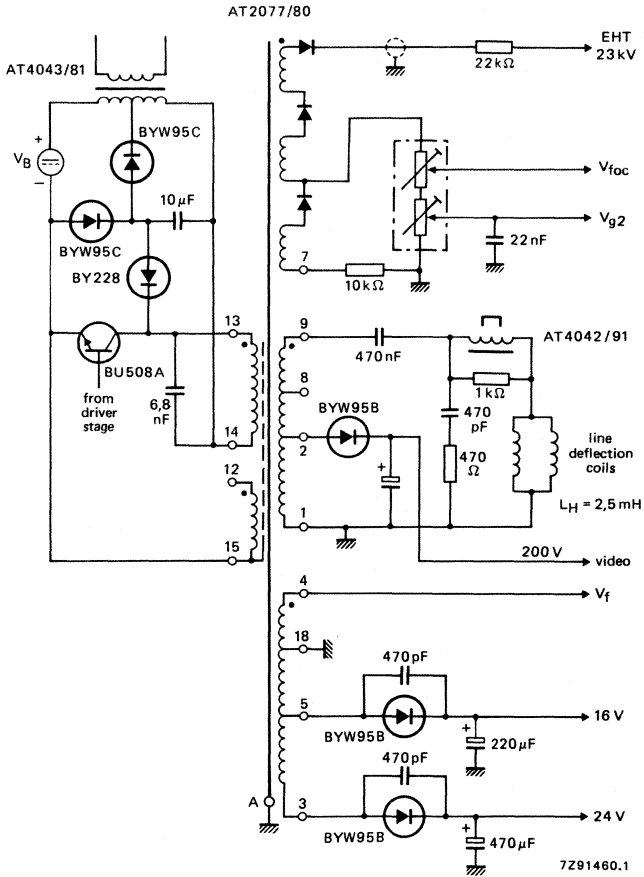

Fig. 5 Application circuit.

DIODE-SPLIT-BOX LINE OUTPUT TRANSFORMER

- For 90° and 110° colour TV and colour monitors with separate power supply
- Three-layer e.h.t. coil
- Aluminium foil primary winding
- Incorporated potentiometers for focusing and V_{g2} adjustment

QUICK REFERENCE DATA

For transistor line output stages; 90° and 110° deflection angle

I_{eht}	0 mA
E.H.T.	25 kV
$R_i(eht)$	$\leq 1,8 \text{ M}\Omega$
I_{p-p} deflection (6% overscan)	4,4 A
Supply voltage (V_B)	152 V
Voltages of primary windings (peak-to-peak values)*	+ 110 V, + 524 V, + 960 V, + 1064 V
Voltages of auxiliary windings (peak-to-peak values)	-283 V, -226 V, -149 V, + 59 V, + 104 V
heater voltage (r.m.s. value)	8,2 V

APPLICATION

This transformer has been designed to provide the required scanning amplitude for 90° and 110° colour picture tubes in transistor equipped television receivers presenting 625 lines at 50 fields per second (CCIR) or 525 lines at 60 fields per second (USA). The transformer may also be used in colour monitors.

It is intended for use in conjunction with:

- linearity corrector AT4042/90 or /08A;
- bridge coil AT4043/100;
- screened e.h.t. cable, length 1 m; catalogue number 3122 137 63370, or unscreened e.h.t. cable, length 59 cm; catalogue number 3122 137 63260;
- focus cable, length 31 cm; catalogue number 3122 131 00732;
- V_{g2} cable, length 30 cm; catalogue number 3122 137 64570.

DESCRIPTION

The magnetic circuit of the transformer comprises 2 Ferroxcube cores, glued together. The primary winding of aluminium foil and the secondary windings are situated on one leg of the core. The primary winding together with its e.h.t. winding and e.h.t. diodes are encapsulated with epoxy resin in a pre-moulded case. The transformer has potentiometers for focusing control and V_{g2} adjustment. The transformer case has 3 holes that enables fixing to a printed-wiring board with self-tapping screws. External circuit connection is made to connecting pins, positioned as indicated in Fig. 1, enabling the unit to be soldered directly into a printed-wiring board (Fig. 4).

* D.C. component on these pulses is V_B' (see Fig. 5).

MECHANICAL DATA
Outlines

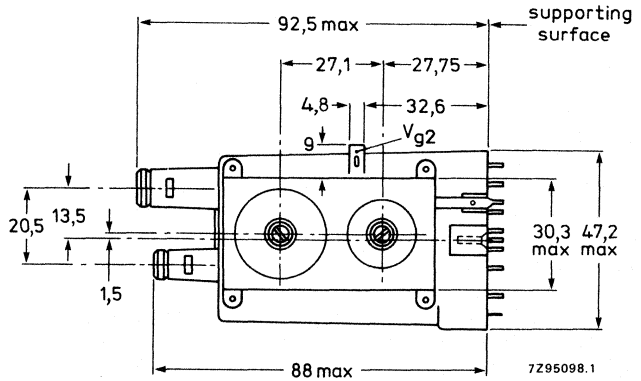
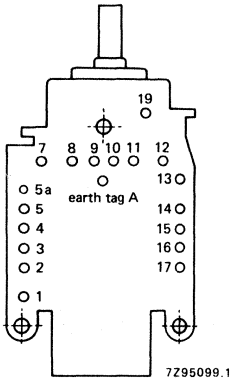
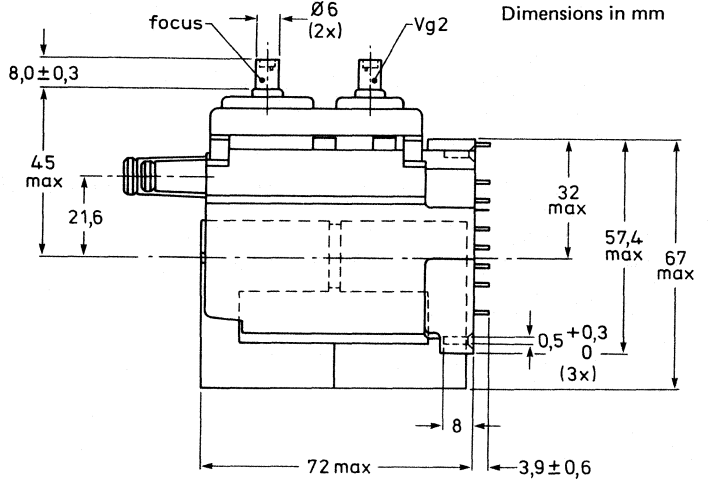

Fig. 1 Line output transformer AT2077/81.

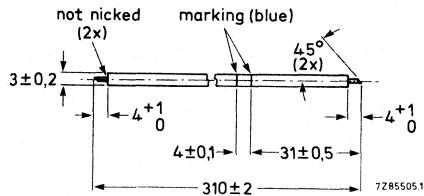

Fig. 2 Focus cable 3122 131 00732.

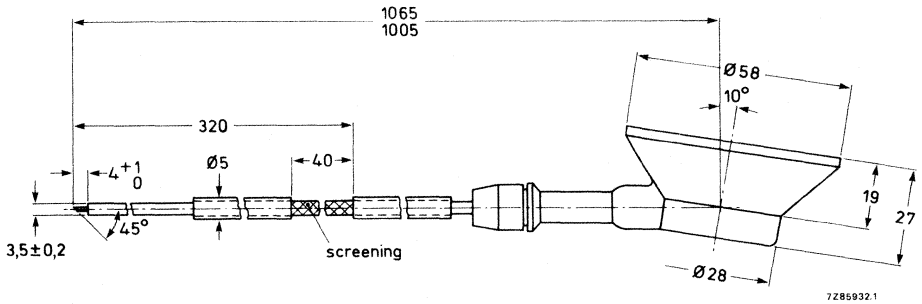

Fig. 3 E.H.T. cable 3122 137 63370.

- Mass** approx. 375 g
- Solderability** in accordance with IEC 68, test T
- Packing** 27 transformers per box

Mounting

The transformer may be mounted on a printed-wiring board. It can be secured with 3 self-tapping screws; the tightening torque on the board is $500 + 300$ mNm. The fit of the connecting pins in a printed-wiring grid with a pitch of 2,54 mm is illustrated in Fig. 4. The transformer core must be earthed via the earth pin (see Fig. 1).

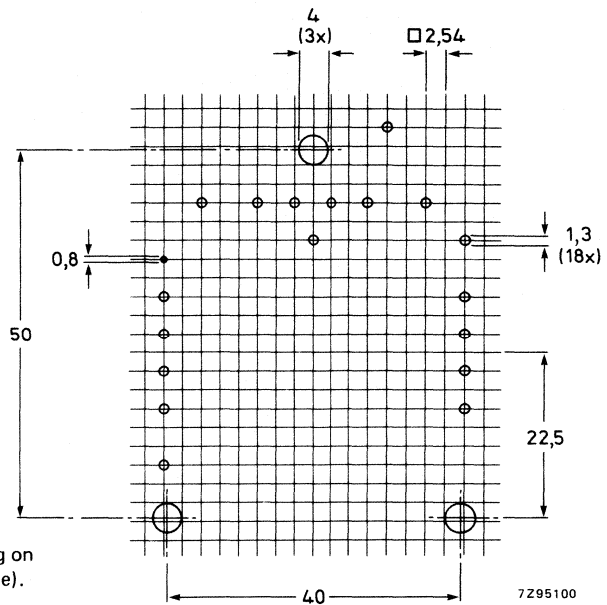

Fig. 4 Hole pattern for mounting on a printed-wiring board (solder side).

Temperature

The operating temperature of the e.h.t. coil should not exceed +60 °C under worst conditions, i.e. taking into account:

- over-voltage on the coils;
- low atmospheric pressure (at high altitudes) implying bad cooling by convection;
- high ambient temperature (up to 45 °C).

To satisfy this requirement it is recommended to provide sufficient flow of cool air around the transformer.

Distances

The following minimum distances between the transformer and neighbouring conductive flat surfaces must be maintained:

- From the e.h.t. coil radially, 10 mm
- From the e.h.t. coil axially, 10 mm

Sharp edges of conductive parts must have greater distances than given above.

The transformer leads and components carrying high-voltage pulses, should be kept free from metal particles, solder drops, etc.

→ **ELECTRICAL DATA**; for use with 110° colour picture tubes, see Fig. 5.

E.H.T. supply	I_{eht} e.h.t. $R_{i(\text{eht})}$	mA kV MΩ	0 25,6	0,5 24,7	1 23,8	1,5 23,7
					1,8	
Power supply	V_B $V_{B'}$ I_B	V	152	152	152	152
		V	148	146,9	144,6	142,6
		mA	250	330	435	458
Output transistor	V_{CEM} $+ I_{\text{CEM}}$	V	1200	1185	1180	1175
		A	3,2	3,3	3,4	3,5
Deflection	deflection current flyback time overscan	A(p-p)	4,4	4,35	4,3	4,25
		μs	11,55	11,55	11,55	11,75
		%	6			
Focusing voltage	min. max.	kV	0,24 x e.h.t.			
		kV	0,36 x e.h.t.			
Grid 2 voltage (V_{g2})	min. max.	V	0,014 x e.h.t.			
		V	0,04 x e.h.t.			
Primary voltages*	pin 9	$V_{(p-p)}$	+ 110			
	pin 14	$V_{(p-p)}$	+ 524			
	pin 16	$V_{(p-p)}$	+ 1064			
	pin 17	$V_{(p-p)}$	+ 960			
Auxiliary voltages	heater voltage (V_{1-3})	$V_{(r.m.s.)}$	8,2	8,0	7,9	7,8
	pin 1	$V_{(p-p)}$	+ 30			
	pin 2	$V_{(p-p)}$	– 283			
	pin 4	$V_{(p-p)}$	+ 59			
	pin 5	$V_{(p-p)}$	– 226			
	pin 7	$V_{(d.c.)}$	1265	1240	1215	1200
	pin 8	$V_{(p-p)}$	+ 104			
	pin 12	$V_{(p-p)}$	– 149			

* D.C. component on these pulses is $V_{B'}$.

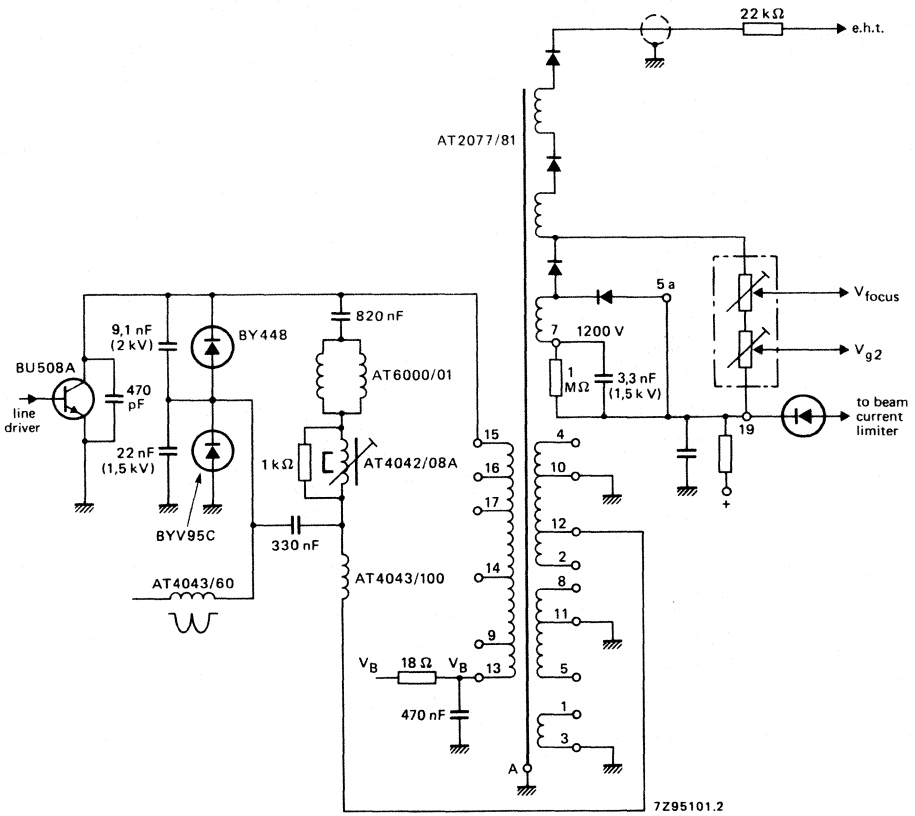

Fig. 5 Application circuit.

→ ELECTRICAL DATA; for use with 51 cm, 90° Flat Square colour picture tube, see Fig. 6.

E.H.T. supply	I_{eh}	mA	0	0,5	1
	e.h.t.	kV	25,4	24,3	23,8
	$R_{i(eht)}$	MΩ		1,8	
Power supply	V_B	V	148,5	148,2	148,0
	$V_{B'}$	V	145	142,9	140,9
	I_B	mA	230	315	400
Output transistor	V_{CEM}	V	1200	1180	1190
	+ I_{CEM}	A	2,38	2,43	2,5
Deflection	deflection current	A(p-p)	3,05	3,0	2,95
	flyback time	μs	10,6	10,7	10,8
	overscan	%	6		
Focusing voltage	min.	kV	0,24 x e.h.t.		
	max.	kV	0,36 x e.h.t.		
Grid 2 voltage (V_{g2})	min.	V	0,014 x e.h.t.		
	max.	V	0,04 x e.h.t.		
Auxiliary voltages	pin 9* (video)	V	230	226	223
	pin 5**	V(d.c.)	55	54	53
	heater voltage	V(r.m.s.)	8,2	8,0	7,9
	pin 4	V(p-p)	+ 59		
	pin 12	V(p-p)	- 149		
	pin 2	V(p-p)	- 283		
	pin 14	V(p-p)	- 253		

* Values apply to voltages after rectification.

** Field time base; approx. 9 W.

DIODE-SPLIT-BOX LINE OUTPUT TRANSFORMER

- For 110° deflection colour TV with twin switch power pack system (TSP²)
- Three-layer e.h.t. coil, with tap for focusing voltage of 26 to 34% of e.h.t. voltage
- Aluminium foil primary winding
- Incorporated focusing potentiometer
- Main insulation

QUICK REFERENCE DATA

For transistor line output stages; 110° deflection angle

I_{eht}	0 mA	
E.H.T.	25 kV	
$R_{\text{i}}(\text{eht})$	$\leq 1 \text{ M}\Omega$	
$I_{\text{p-p}}$ deflection	4,3 A	←
Supply current at $I_{\text{eht}} = 1,1 \text{ mA}$	850 mA \pm 10%	←
Auxiliary voltages	8,2 V (heater supply)	←
	210 V (video supply)	←
	26 V (frame)	
	12 V (small signal)	←
	5 V (teletext)	←
	150 V (scan voltage)	

APPLICATION

This transformer has been designed to provide the required scanning amplitude for 110° colour picture tubes in transistor equipped television receivers presenting 625 lines at 50 fields per second (CCIR) or 525 lines at 60 fields per second (USA). The transformer may also be used in colour monitors.

It is intended for use in conjunction with:

- input choke AT4043/16A;
- driver transformer AT4043/29;
- pulse transformer AT4043/76;
- mains filter choke AT4043/90;
- audio choke AT4043/96;
- screened e.h.t. cable, length 1 m; catalogue number 3122 137 63370;
- focus cable, length 31 cm; catalogue number 3122 131 00732.

DESCRIPTION

The magnetic circuit of the transformer comprises 2 Ferroxcube cores, glued together. The primary winding of aluminium foil and the secondary windings are situated on one leg of the core. The primary winding together with its e.h.t. winding and e.h.t. diodes are encapsulated with epoxy resin in a pre-moulded case. The transformer is provided with a focusing control potentiometer. The transformer case has 3 holes that enables fixing to a printed-wiring board with self-tapping screws. External circuit connection is made to connecting pins, positioned as indicated in Fig. 1, enabling the unit to be soldered directly into a printed-wiring board (Fig. 2).

MECHANICAL DATA

Outlines

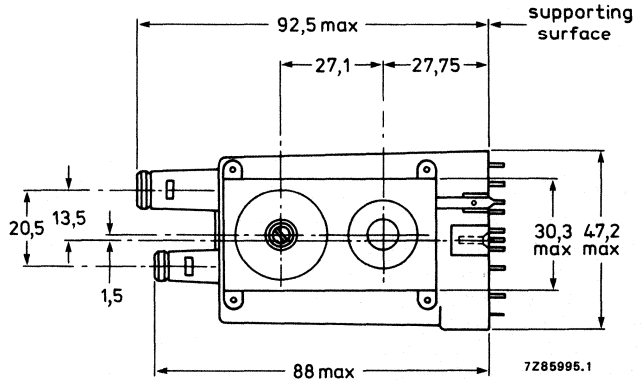
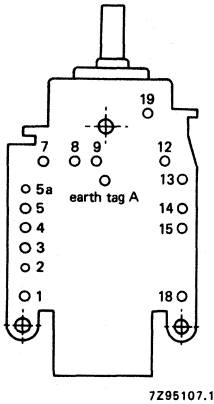
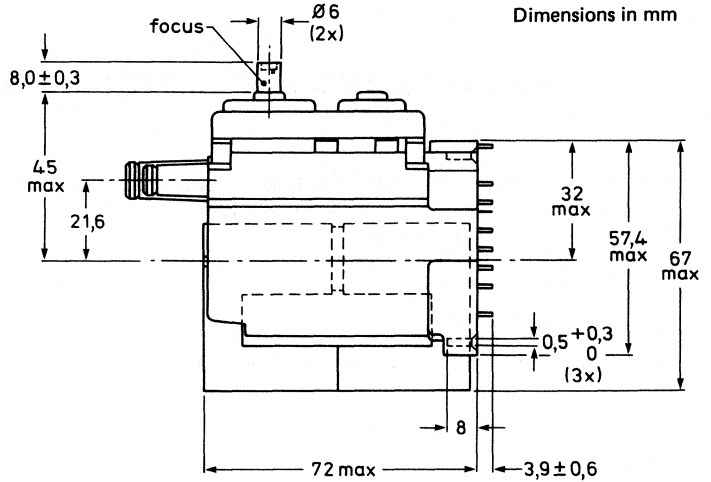

Fig. 1 Line output transformer AT2077/82.

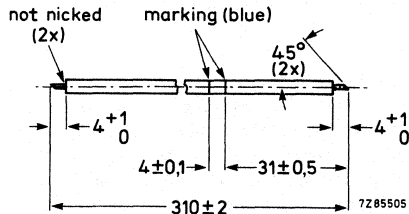

Fig. 2 Focus cable 3122 131 00732.

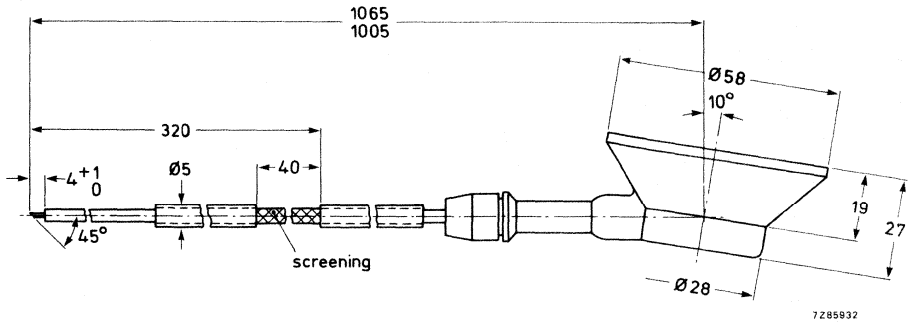

Fig. 3 E.H.T. cable 3122 137 63370.

- Mass** approx. 325 g
- Solderability** in accordance with IEC 68, test T
- Packing** 27 transformers per box
- Mounting**

The transformer may be mounted on a printed-wiring board. It can be secured with 3 self-tapping screws; the tightening torque on the board is 500 + 300 mNm. The fit of the connecting pins in a printed-wiring grid with a pitch of 2,54 mm is illustrated in Fig. 4. The transformer core must be earthed via the earth pin (see Fig. 1).

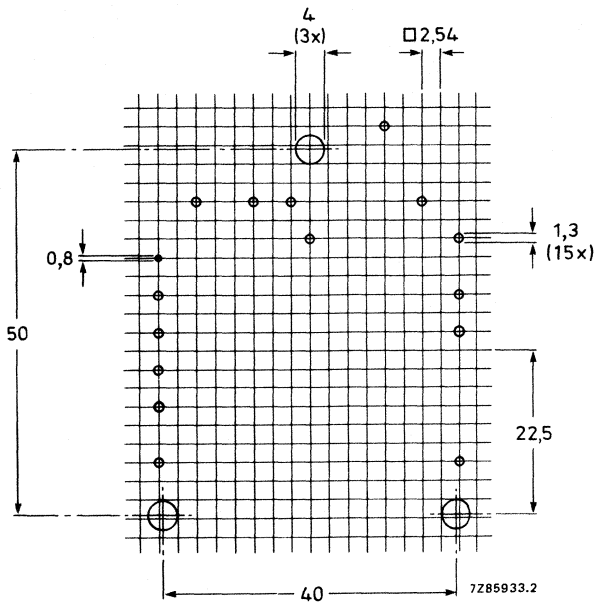

Fig. 4 Hole pattern for mounting on a printed-wiring board (solder side).

Temperature

The operating temperature of the e.h.t. coil should not exceed + 60 °C under worst conditions, i.e. taking into account:

- over-voltage on the coils;
- low atmospheric pressure (at high altitudes) implying bad cooling by convection;
- high ambient temperature (up to 45 °C).

To satisfy this requirement it is recommended to provide sufficient flow of cool air around the transformer.

Distances

The following minimum distances between the transformer and **neighbouring conductive flat surfaces** must be maintained:

From the e.h.t. coil radially, 10 mm

From the e.h.t. coil axially, 10 mm

Sharp edges of conductive parts must have greater distances than given above.

The transformer leads and components carrying high-voltage pulses, should be kept free from metal particles, solder drops, etc.

ELECTRICAL DATA with 110° colour picture tubes

E.H.T. supply	I_{eht}	mA	0,1	1,1	1,6
	e.h.t.	kV	25,0	24,1	23,65
	$R_{\text{i}}(\text{eht})$	MΩ		0,9	
Power supply	V_{B}	V	100	101	101,5
	V_{CEM}^*	V	1260	1270	1290
	I_{CEM}	A	1,7	2,1	2,15
Deflection	Overscan	%	6		6
	V_{g}	V	150	150	150
	Flyback time	μs	11,5	11,5	11,5
	V_{CEM}	V	1220	1230	1235
	I_{CEM}	A	3,45	3,65	3,8
	Deflection current	A (p-p)	4,3	4,3	4,3
Focusing voltage	min.	kV	5,6		
	max.		9,1		
Auxiliary windings:					
picture tube heater voltage, V_4	$V_{\text{(r.m.s.)}}$		8,2	8,2	8,2
Voltages (peak-to-peak values)** at					
pin 1	V_1	V (d.c.)	+ 1220		
pin 2	V_2	V	+ 87 to + 139		
pin 3	V_3	V	-218		
pin 4	V_4	V	+ 29		
pin 5	V_5	V	-129		
pin 7	V_7	V	+ 1145		
pin 8	V_8	V	-74		
pin 9	V_9	V (d.c.)	+ 150		
pin 15	V_{15}	$V_{\text{(p-p)}}$	-80		

* At mains voltage 220 V.

** Pin 18 connected to earth.

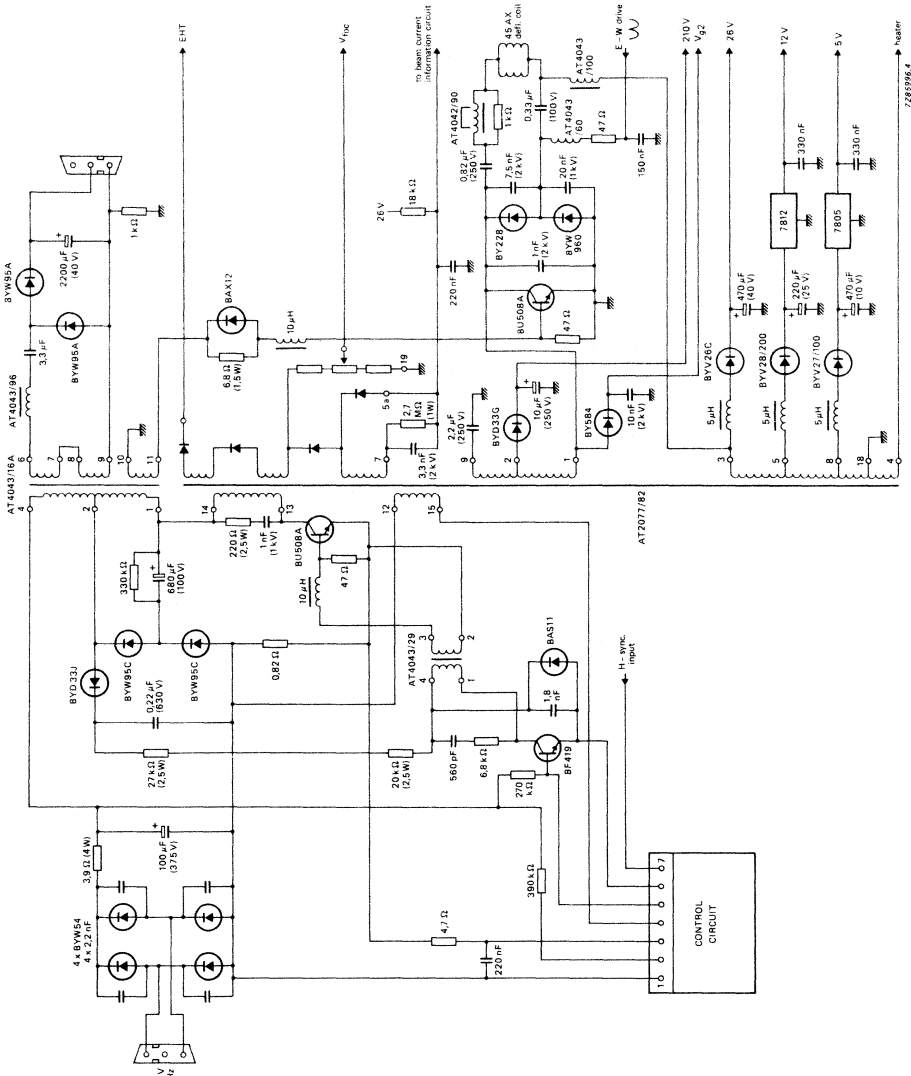

Fig. 5 Application circuit.

LINE OUTPUT TRANSFORMER

"Micro slot"

- For 90° colour TV and colour monitors
- Incorporated potentiometers and cables for focusing and V_{g2} adjustment

QUICK REFERENCE DATA

For transistor line output stages; 90° deflection angle

I_{eht}	≤ 1 mA
E.H.T.	23 kV
$R_{i(eht)}$	≤ 2 MΩ
I_{p-p} deflection	2,2 A
Supply voltage (V_B)	112 V
Supply current at $I_{eht} = 0,9$ mA	480 mA
Focusing voltage control	25 to 34,5% of E.H.T.
Grid 2 voltage control	110 to 1000 V
Auxiliary voltages	7,2 V (r.m.s.) (heater supply) + 178 V (video supply) + 27,2 V (frame) + 13,4 V (small signal) 140 V (p-p) (reference pulse)

APPLICATION

This transformer has been designed to provide the required scanning amplitude for 90° colour picture tubes in transistor equipped television receivers presenting 625 lines at 50 fields per second (CCIR) or 525 lines at 60 fields per second (USA). The transformer may also be used in colour monitors.

DESCRIPTION

The magnetic circuit of the transformer comprises 2 Ferroxcube cores, glued together. The primary winding and the secondary windings are situated on one leg of the core. The primary winding together with its e.h.t. winding and e.h.t. diodes are encapsulated with epoxy resin in a pre-moulded case. The transformer has potentiometers for focusing control and V_{g2} adjustment. External circuit connection is made to connecting pins, positioned as indicated in Fig.1, enabling the unit to be soldered directly into a printed-wiring board.

For mechanized mounting this line output transformer can also be supplied without cables.

Dimensions in mm

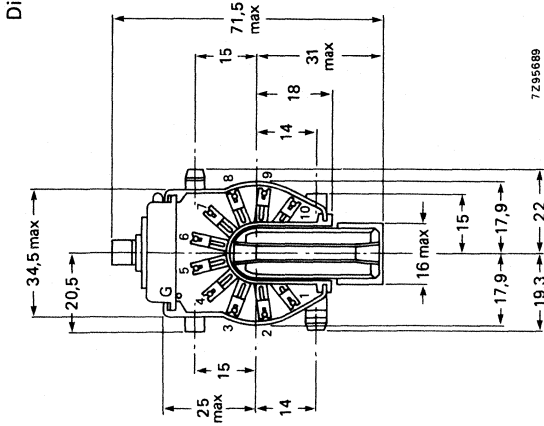

7295689

MECHANICAL DATA
Outlines

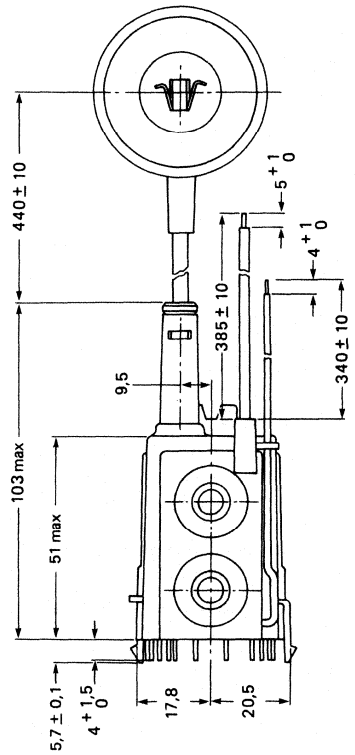
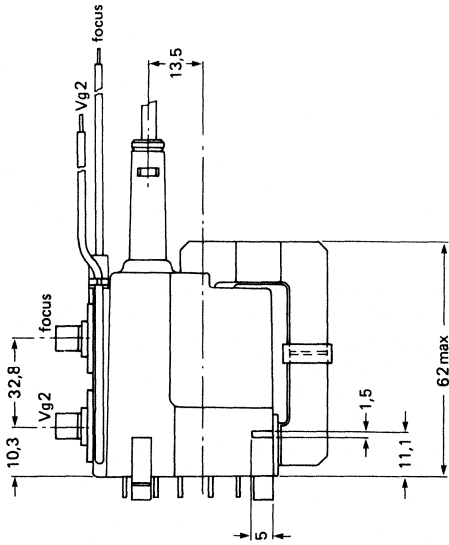

Fig. 1.

- Mass** approx. 190 g
- Solderability** in accordance with IEC 68, test Ta
- Packing** 24 transformers per box
- Mounting**

For mounting hole pattern see Fig. 2. The transformer core must be earthed via the earth tag (G, Fig. 1).

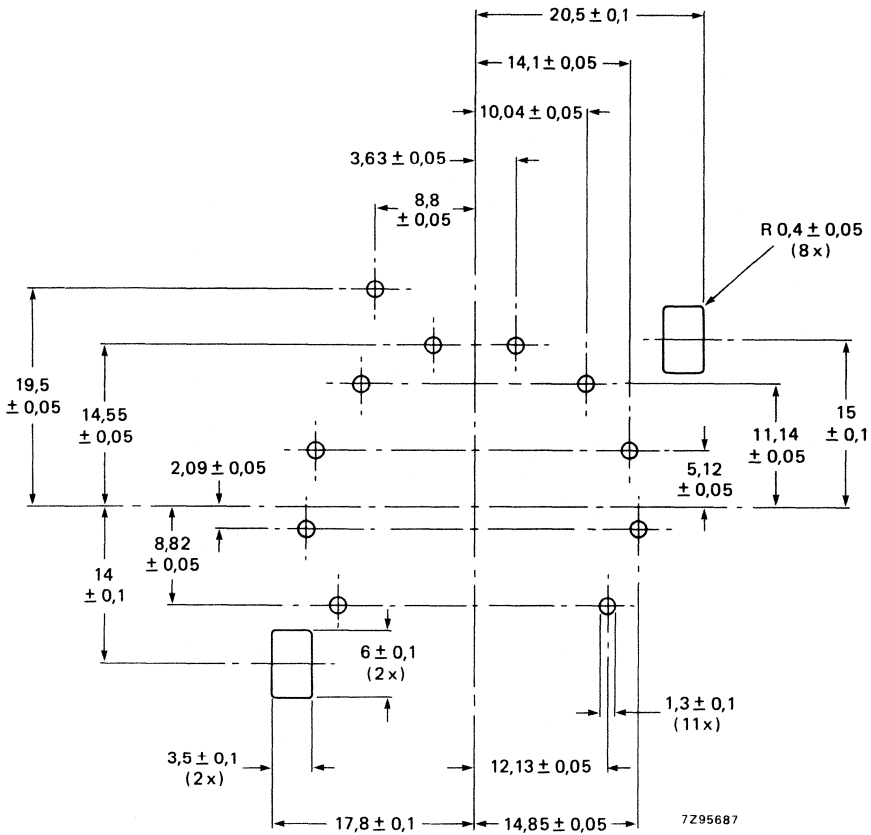

Fig. 2 Mounting hole pattern (solder side).

MECHANICAL DATA (continued)**Temperature**

The operating temperature of the e.h.t. coil should not exceed + 60 °C under worst conditions, i.e. taking into account:

- over-voltage on the coils;
- low atmospheric pressure (at high altitudes) implying bad cooling by convection;
- high ambient temperature (up to 45 °C).

To satisfy this requirement it is recommended to provide sufficient flow of cool air around the transformer.

Distances

The minimum distance between the e.h.t. coil and neighbouring conductive flat surfaces is 10 mm.

Sharp edges of conductive parts must have greater distances.

The transformer leads and components carrying high-voltage pulses, should be kept free from metal particles, solder drops, etc.

ELECTRICAL DATA

E.H.T. supply	I_{eht} E.H.T. $R_{\text{i(eht)}}$	$\leq 0,9$ mA 23 kV ≤ 2 M Ω
Power supply	V_{B} I_{average}	112 V 480 mA
Output transistor	V_{CEM} $+ I_{\text{CEM}}$	970 V 1,9 A
Deflection	deflection current (p-p) flyback time line frequency deflection coil inductance	2,2 A 10,9 μ s 15625 Hz 2,7 mH
Focusing voltage	min.	25% of E.H.T.
Focusing current	max.	34,5% of E.H.T. 120 μ A
Grid 2 voltage (V_{g2})	min. (d.c.) max. (d.c.)	110 V 1000 V
Auxiliary voltages	pin 3, V_3 (r.m.s.) pin 2, V_2 (d.c.) pin 4, V_4 (d.c.) pin 6, V_6 (d.c.) pin 8, V_8 (p-p)	7,2 V (heater voltage) + 178 V (video supply) + 27,2 V (frame supply) + 13,4 V (small signal supply) 140 V (reference pulse)

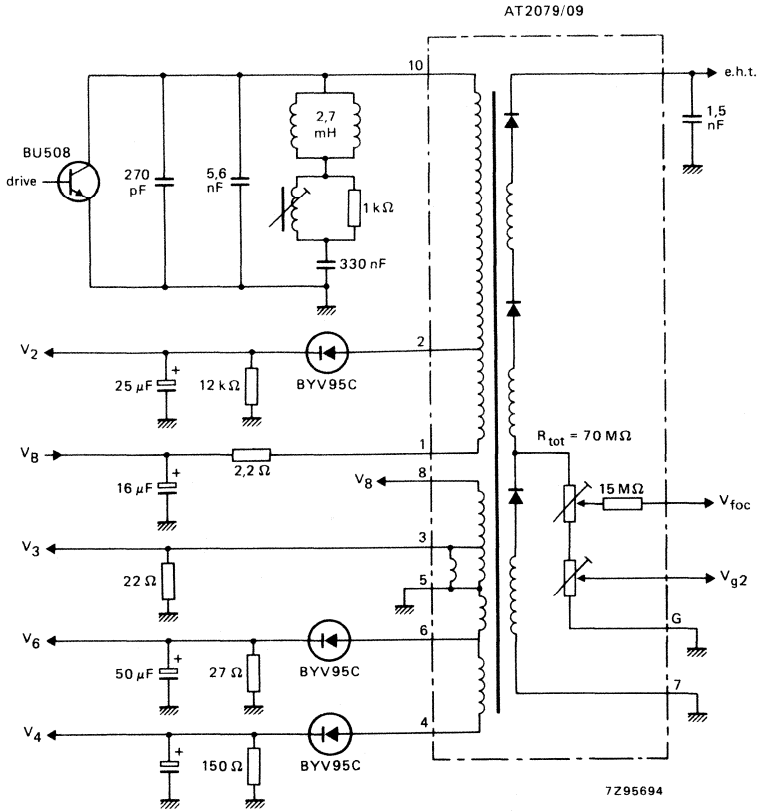

Fig. 3 Application circuit.

LINE OUTPUT TRANSFORMER

"Micro slot"

- For 90° colour TV and colour monitors
- Incorporated potentiometers and cables for focusing and V_{g2} adjustment

QUICK REFERENCE DATA

For transistor line output stages; 90° deflection angle

I_{eht}	≤ 1 mA
E.H.T.	25,5 kV
$R_{i(eht)}$	≤ 2 M Ω
I_{p-p} deflection	2,6 A
Supply voltage (V_B)	95 V
Supply current at $I_{eht} = 0,9$ mA	580 mA
Focusing voltage control	26 to 34,5% of E.H.T.
Grid 2 voltage control	220 to 830 V
Auxiliary voltages	6,8 V (heater supply) + 163,2 V (video supply) + 12,7 V + 7,3 V

APPLICATION

This transformer has been designed to provide the required scanning amplitude for 90° colour picture tubes in transistor equipped television receivers presenting 625 lines at 50 fields per second (CCIR) or 525 lines at 60 fields per second (USA). The transformer may also be used in colour monitors.

DESCRIPTION

The magnetic circuit of the transformer comprises 2 Ferroxcube cores, glued together. The primary winding and the secondary windings are situated on one leg of the core. The primary winding together with its e.h.t. winding and e.h.t. diodes are encapsulated with epoxy resin in a pre-moulded case. The transformer has potentiometers for focusing control and V_{g2} adjustment. External circuit connection is made to connecting pins, positioned as indicated in Fig. 1, enabling the unit to be soldered directly into a printed-wiring board.

For mechanized mounting this line output transformer can also be supplied without cables.

Dimensions in mm

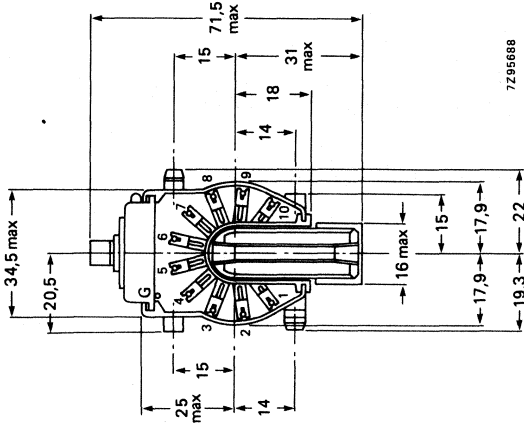

7295688

MECHANICAL DATA
Outlines

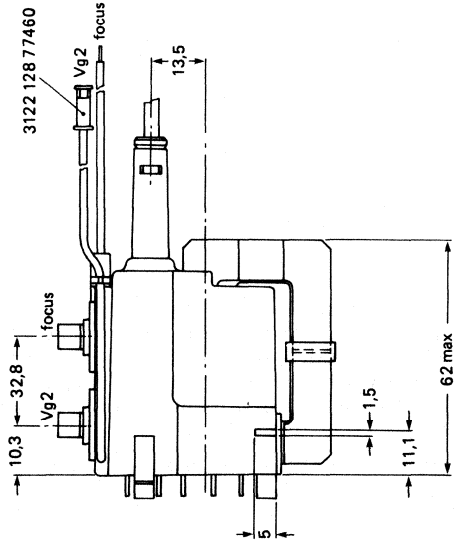

3122 128 77460

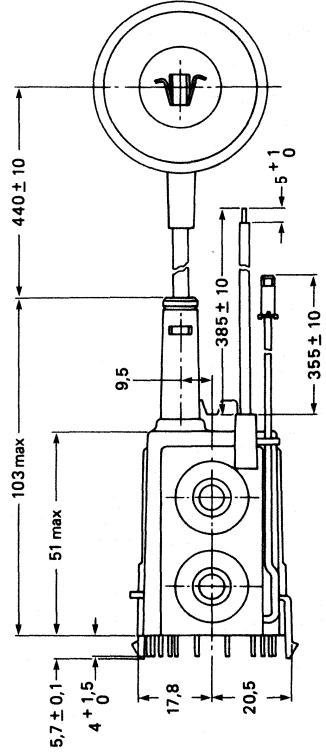

Fig. 1.

- Mass** approx. 210 g
- Solderability** in accordance with IEC 68, test Ta
- Packing** 24 transformers per box

Mounting

For mounting hole pattern see Fig. 2. The transformer core must be earthed via the earth tag (G, Fig. 1).

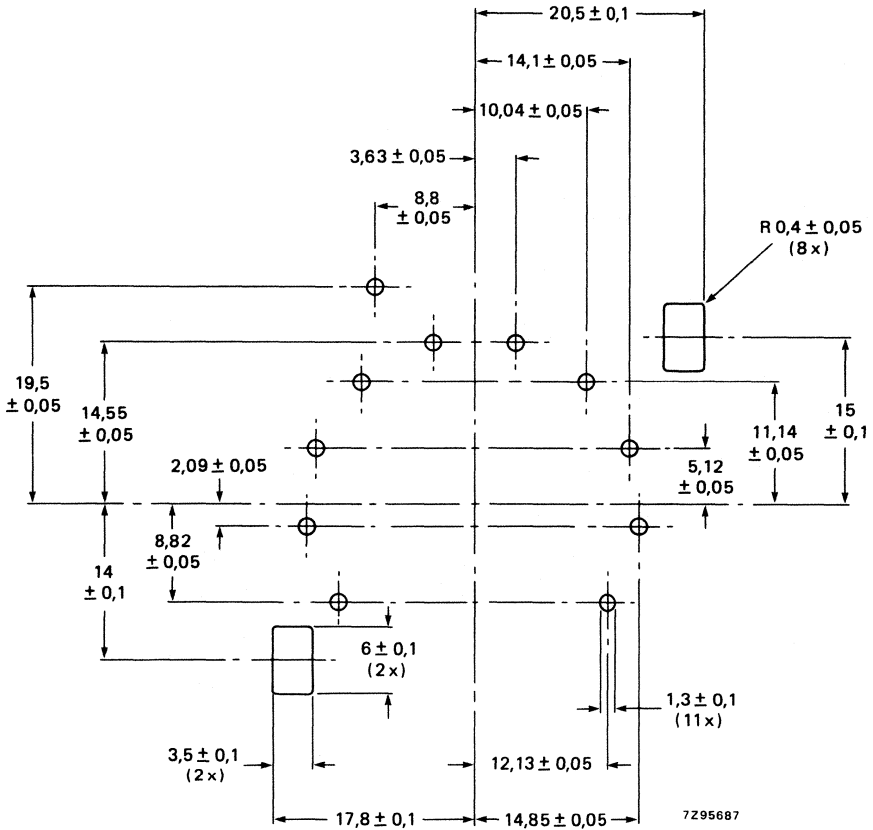

Fig. 2 Mounting hole pattern (solder side).

MECHANICAL DATA (continued)**Temperature**

The operating temperature of the e.h.t. coil should not exceed + 60 °C under worst conditions, i.e. taking into account:

- over-voltage on the coils;
- low atmospheric pressure (at high altitudes) implying bad cooling by convection;
- high ambient temperature (up to 45 °C).

To satisfy this requirement it is recommended to provide sufficient flow of cool air around the transformer.

Distances

The minimum distance between the e.h.t. coil and neighbouring conductive flat surfaces is 10 mm.

Sharp edges of conductive parts must have greater distances.

The transformer leads and components carrying high-voltage pulses, should be kept free from metal particles, solder drops, etc.

ELECTRICAL DATA; see application circuit with diode modulator, Fig. 3.

E.H.T supply	I_{eht} E.H.T. $R_{\text{i}}(\text{eht})$	$\leq 1 \text{ mA}$ 25,5 kV $\leq 2 \text{ M}\Omega$
Power supply	V_{B} I_{average}	95 V 580 mA
Output transistor	V_{CEM} $+ I_{\text{CEM}}$	820 V 2,4 A
Deflection	deflection current (p-p) flyback time line frequency deflection coil inductance	2,6 A 11,2 μs 15625 Hz 2,5 mH
Focusing voltage	min.	26% of E.H.T
Focusing current	max.	34,5% of E.H.T. 120 μA
Grid 2 voltage (V_{g2})	min (d.c.) max. (d.c.)	220 V 830 V
Auxiliary voltages	pin 8, V_{g} (r.m.s.) pin 1, $V_{1\text{a}}$ (d.c.) pin 2, $V_{2\text{a}}$ (d.c.) pin 3, $V_{3\text{a}}$ (d.c.)	6,8 V (heater voltage) + 163,2 V (video supply) + 12,7 V + 7,3 V

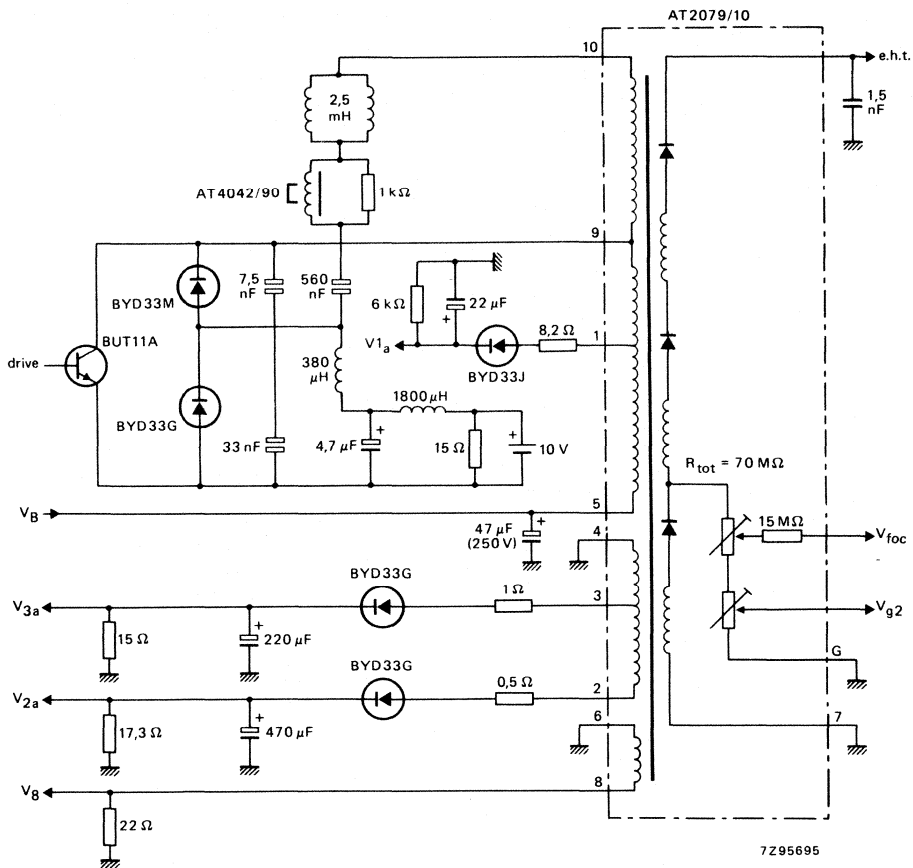

Fig. 3 Application circuit with diode modulator.

ELECTRICAL DATA; see application circuit for 90° flat square picture tube A51EAL00X, Fig. 4.

E.H.T. supply	I_{eht}	$\leq 1 \text{ mA}$
	E.H.T.	25,5 kV
	$R_{i(\text{eht})}$	$\leq 2,5 \text{ M}\Omega$
Power supply	V_B	116 V
Output transistor	V_{CEM}	950 V
	$+ I_{\text{CEM}}$	2,4 A
Deflection	deflection current (p-p)	2,85 A
	flyback time	11,8 μs
	line frequency	15625 Hz
	deflection coil inductance	2,0 mH
Focusing voltage	min.	26% of E.H.T.
Focusing current	max.	34,5% of E.H.T.
		130 μA
Grid 2 voltage (V_{g2})	min. (d.c.)	220 V
	max. (d.c.)	830 V
Auxiliary voltages	pin 8, V_g (r.m.s.)	6,8 V (heater voltage)
	pin 5, V_{5a} (d.c.)	+ 190 V (video supply)

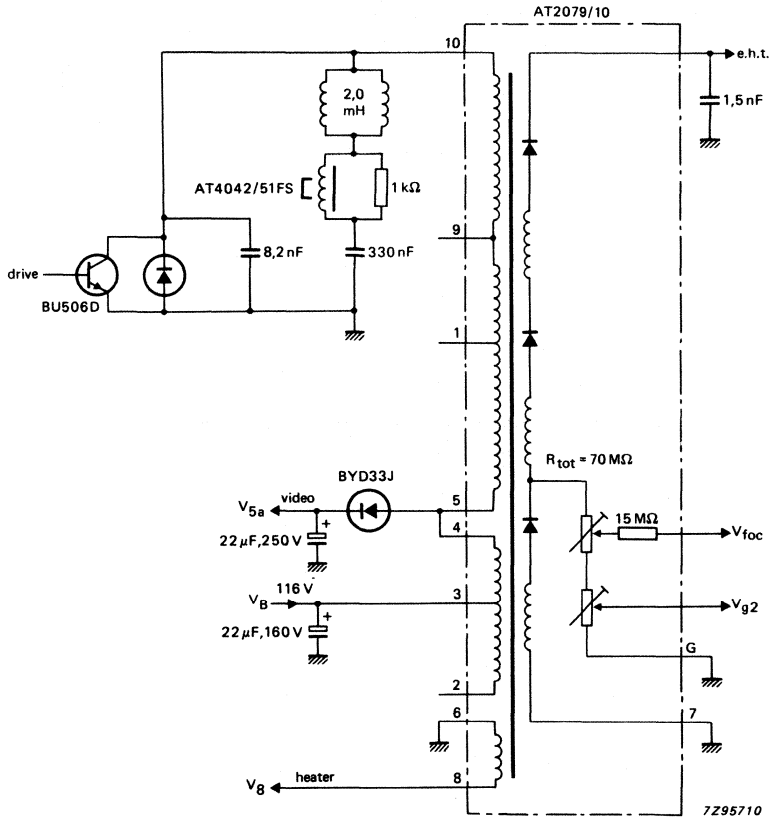

Fig. 4 Application circuit for 90° flat square picture tube A51EAL00X.

Replaced by AT2102/02A ←

LINE OUTPUT TRANSFORMER

- For Monochrome Data Graphic Displays

QUICK REFERENCE DATA

	used in conjunction with AT1071/03		used in conjunction with AT1074/01	
	I_{eht} E.H.T.	0 μA 14,9 kV	100 μA 13,9 kV	0 μA 14,7 kV
$R_{\text{i(eht)}}$	10 $\text{M}\Omega$		11 $\text{M}\Omega$	
Supply voltage (V_{B})	12 V	12 V	12 V	12 V
Supply current (I_{B})	1725 mA	1825 mA	1700 mA	1800 mA
Deflection current	8,5 A	8,4 A	5,0 A (p-p)	4,95 A (p-p)
Auxiliary voltages	6,3 V (r.m.s.), 11 V (r.m.s.), 66 V (d.c.), 790 V (d.c.)			

APPLICATION

This transformer has been designed to provide the required scanning amplitude for 24 cm (9 in) to 31 cm (12 in) 90° monochrome monitor tubes in video display monitors presenting 625 lines at 50 frames per second (CCIR) or 525 lines at 60 frames per second (USA).

It is intended for use in conjunction with the following packages of components:

- deflection unit AT1071/03 or AT1071/07;
- adjustable linearity control unit AT4036/00A;
- line driver transformer AT4043/64;
- deflection unit AT1074/01;
- adjustable linearity control unit AT4042/26A;
- line driver transformer AT4043/56.

DESCRIPTION

The magnetic circuit of the transformer comprises Ferroxcube U and I-cores clamped together with two screws. The primary windings and the auxiliary windings are situated on one leg of the core, the e.h.t. winding and the coupling winding are situated on the other leg. The e.h.t. winding is encapsulated in flame retardant polyester. An e.h.t. rectifier diode is incorporated in the transformer. The whole transformer meets the self-extinguishing and non-dripping properties of the American Underwriters' Laboratories rating mentioned in UL94SE-1.

The transformer is provided with four mounting pins; it can also be screwed to the printed-wiring board. External circuit connection is made to connecting pins, enabling the unit to be soldered directly into a printed-wiring board.

MECHANICAL DATA

Dimensions in mm

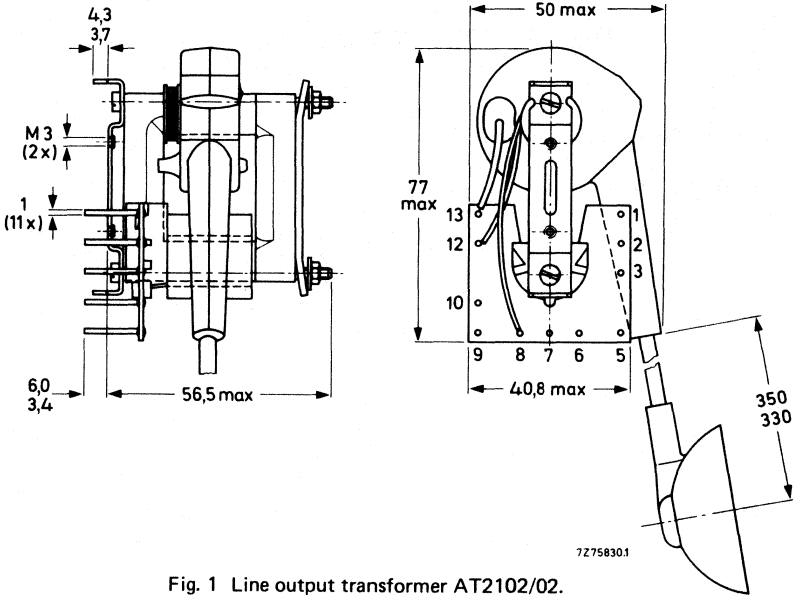

Fig. 1 Line output transformer AT2102/02.

MOUNTING

The transformer may be mounted on a printed-wiring board. The fit of the connecting and mounting pins in a printed-wiring grid with a pitch of 2,54 mm (0,1 in) is illustrated in Fig. 2. The core of the transformer must be earthed.

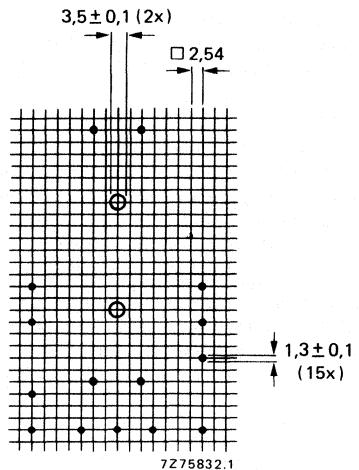

Fig. 2 Hole pattern for mounting on a printed-wiring board (solder side).

Temperature

The operating temperature of the core and the coils should not exceed 90 °C, under worst conditions, i.e. taking into account:

- over-voltage on the windings;
- low atmospheric pressure (at high altitudes) implying bad cooling by convection;
- high room temperature (up to 45 °C).

To satisfy this requirement it may be desired to provide ample cool air circulation around the transformer.

Distances

The following minimum distances between the transformer and neighbouring conductive flat surfaces must be maintained (in proportion to their sharpness protruding parts must have a greater distance):

- a. From the e.h.t. winding, radially 15 mm, axially 10 mm.
- b. From the e.h.t. lead 25 mm.

The transformer, and the leads and components carrying high-voltage pulses should be kept free from metal particles, solder drops etc.

ELECTRICAL DATA (see also Figs 3 and 4)

		AT2102/02 used in conjunction with AT1071/03		AT2102/02 used in conjunction with AT1074/01	
		0 μ A 14,9 kV	100 μ A 13,9 kV	0 μ A 14,7 kV	100 μ A 13,6 kV
E.H.T. supply	I_{eht} E.H.T. $R_{i(\text{eht})}$	10 M Ω		11 M Ω	
Power supply	V_B I_{av}	12 V 1725 mA	12 V 1825 mA	12 V 1700 mA	12 V 1800 mA
Output transistor	V_{CEM} I_{CM}	144 V 6,4 A	144 V 6,4 A	142 V 6,2 A	142 V 6,2 A
Deflection	Current Flyback time Scan variation	8,5 A (p-p) 9,9 μ s 1,5 %	8,4 A (p-p) 9,9 μ s	5,0 A (p-p) 10 μ s 2 %	4,95 A (p-p) 10 μ s

Auxiliary windings

connection pins 1 and 2	6,3 V (r.m.s.)
connecting pins 1 and 3	11 V (r.m.s.)
connecting pin 5 (pin 6 connected to earth)	790 V (d.c.)
connecting pin 7 (pin 6 connected to earth)	66 V (d.c.)

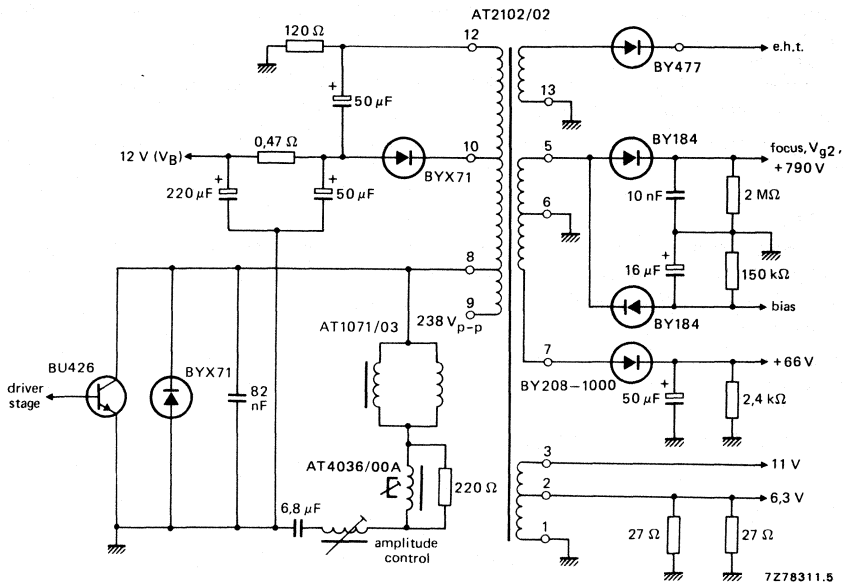

Fig. 3 Application circuit for use with deflection units AT1071/03 and AT1071/07.

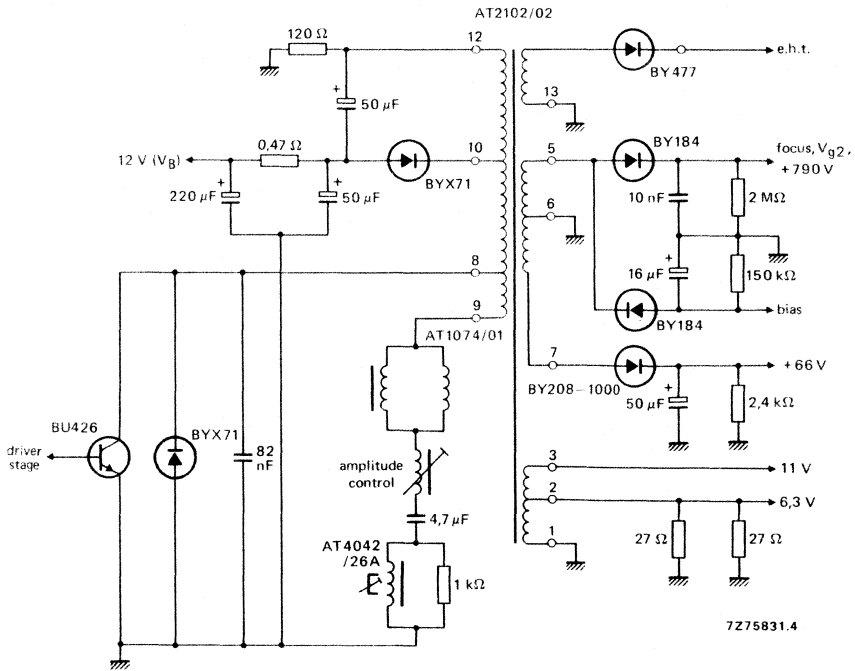

Fig. 4 Application circuit for use with deflection unit AT1074/01.

LINE OUTPUT TRANSFORMER

- For Monochrome Data Graphic Displays

QUICK REFERENCE DATA

	used in conjunction with AT1071/03		used in conjunction with AT1074/01	
I_{eht}	0 μ A	100 μ A	0 μ A	100 μ A
E.H.T.	14,9 kV	13,9 kV	14,7 kV	13,6 kV
$R_i(eht)$	10 M Ω		11 M Ω	
Supply voltage (V_B)	12 V	12 V	12 V	12 V
Supply current (I_B)	1725 mA	1825 mA	1700 mA	1800 mA
Deflection current	8,5 A	8,4 A	5,0 A (p-p)	4,95 A (p-p)
Auxiliary voltages	6,3 V (r.m.s.), 11 V (r.m.s.), 66 V (d.c.), 790 V (d.c.)			

APPLICATION

This transformer has been designed to provide the required scanning amplitude for 24 cm (9 in) to 31 cm (12 in) 90° monochrome monitor tubes in video display monitors presenting 625 lines at 50 frames per second (CCIR) or 525 lines at 60 frames per second (USA).

It is intended for use in conjunction with the following packages of components:

- deflection unit AT1071/03 or AT1071/07;
- adjustable linearity control unit AT4036/00A;
- line driver transformer AT4043/64;
- deflection unit AT1074/01;
- adjustable linearity control unit AT4042/26A;
- line driver transformer AT4043/56.

DESCRIPTION

The magnetic circuit of the transformer comprises Ferroxcube U and I-cores clamped together with two screws. The primary windings and the auxiliary windings are situated on one leg of the core, the e.h.t. winding and the coupling winding are situated on the other leg. The e.h.t. winding is encapsulated in flame retardant polyester. An e.h.t. rectifier diode is incorporated in the transformer. The whole transformer meets the self-extinguishing and non-dripping properties of the American Underwriters' Laboratories rating mentioned in UL94SE-1.

The transformer is provided with four mounting pins; it can also be screwed to the printed-wiring board. External circuit connection is made to connecting pins, enabling the unit to be soldered directly into a printed-wiring board.

MECHANICAL DATA

Dimensions in mm

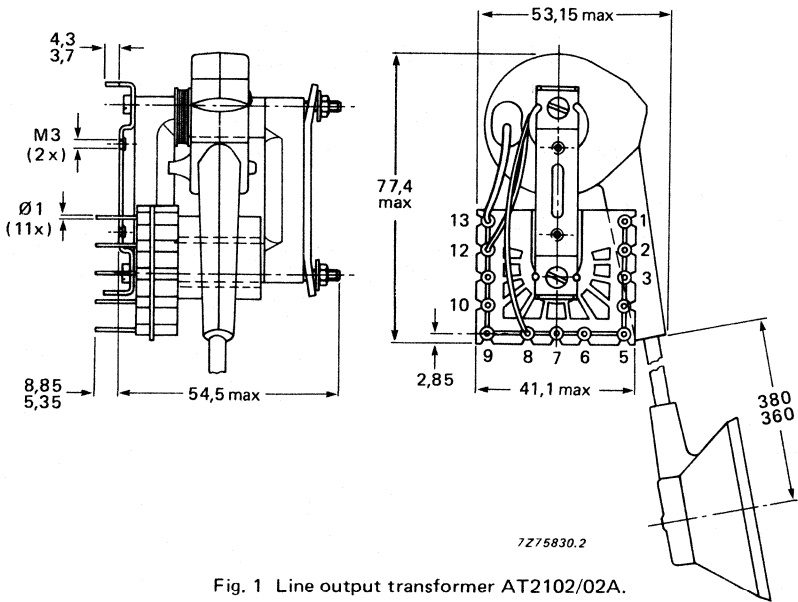

Fig. 1 Line output transformer AT2102/02A.

MOUNTING

The transformer may be mounted on a printed-wiring board. The fit of the connecting and mounting pins in a printed-wiring grid with a pitch of 2,54 mm (0,1 in) is illustrated in Fig. 2. The core of the transformer must be earthed.

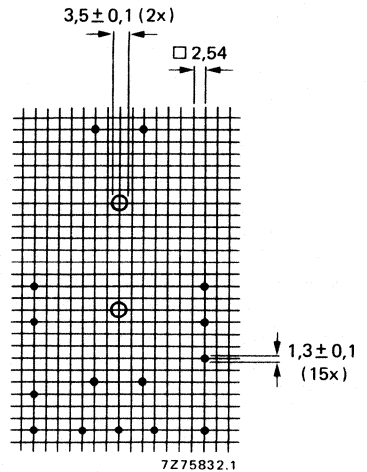

Fig. 2 Hole pattern for mounting on a printed-wiring board (solder side).

Temperature

The operating temperature of the core and the coils should not exceed 90 °C, under worst conditions, i.e. taking into account:

- over-voltage on the windings;
- low atmospheric pressure (at high altitudes) implying bad cooling by convection;
- high room temperature (up to 45 °C).

To satisfy this requirement it may be desired to provide ample cool air circulation around the transformer.

Distances

The following minimum distances between the transformer and neighbouring conductive flat surfaces must be maintained (in proportion to their sharpness protruding parts must have a greater distance):

- a. From the e.h.t. winding, radially 15 mm, axially 10 mm.
- b. From the e.h.t. lead 25 mm.

The transformer, and the leads and components carrying high-voltage pulses should be kept free from metal particles, solder drops etc.

ELECTRICAL DATA (see also Figs 3 and 4)

		AT2102/02A used in conjunction with AT1071/03		AT2102/02A used in conjunction with AT1074/01	
E.H.T. supply	I_{eht}	0 μA	100 μA	0 μA	100 μA
	E.H.T. $R_i(\text{eht})$	14,9 kV 10 M Ω	13,9 kV 10 M Ω	14,7 kV 11 M Ω	13,6 kV 11 M Ω
Power supply	V_B	12 V	12 V	12 V	12 V
	I_{av}	1725 mA	1825 mA	1700 mA	1800 mA
Output transistor	V_{CEM}	144 V	144 V	142 V	142 V
	I_{CM}	6,4 A	6,4 A	6,2 A	6,2 A
Deflection	Current	8,5 A (p-p)	8,4 A (p-p)	5,0 A (p-p)	4,95 A (p-p)
	Flyback time	9,9 μs	9,9 μs	10 μs	10 μs
	Scan variation	1,5 %		2 %	

Auxiliary windings

connection pins 1 and 2	6,3 V (r.m.s.)
connecting pins 1 and 3	11 V (r.m.s.)
connecting pin 5 (pin 6 connected to earth)	790 V (d.c.)
connecting pin 7 (pin 6 connected to earth)	66 V (d.c.)

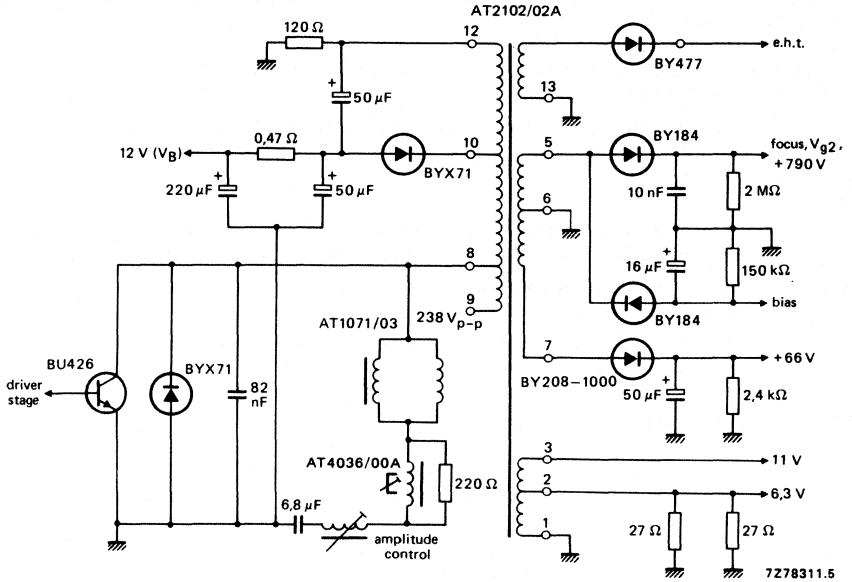

Fig. 3 Application circuit for use with deflection units AT1071/03 and AT1071/07.

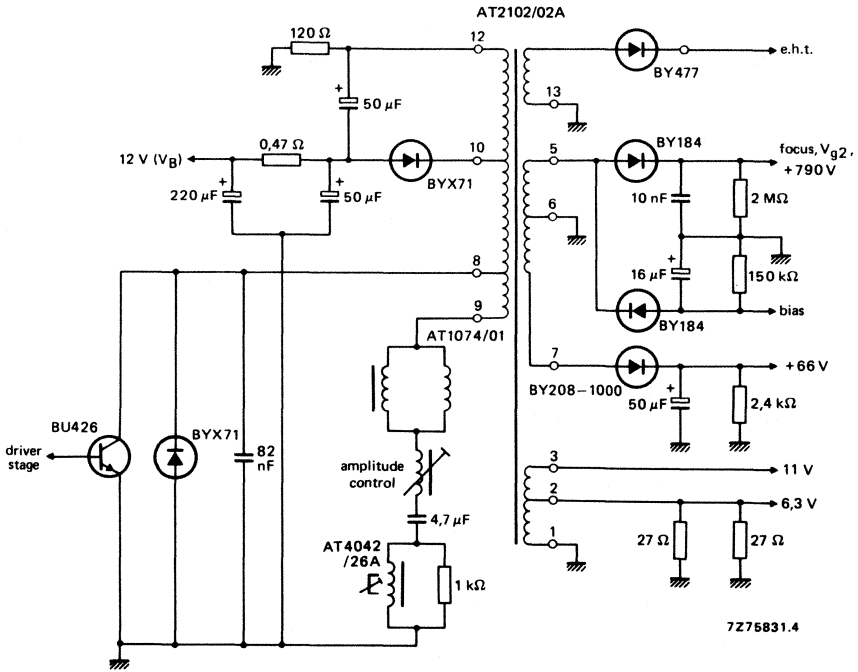

Fig. 4 Application circuit for use with deflection unit AT1074/01.

LINE OUTPUT TRANSFORMER

- For Monochrome Data Graphic Displays

QUICK REFERENCE DATA

I_{eht}	0 μA	100 μA
E.H.T.	17 kV	16,35 kV
$R_{\text{i(eht)}}$	6,5 $\text{M}\Omega$	
Supply voltage (V_{B})	24 V	24 V
Supply current (I_{B})	820 mA	910 mA
Deflection current	4,6 A (p-p)	4,6 A (p-p)
Auxiliary voltages	6,3 V (r.m.s.), 25 V (d.c.), 70 V (d.c.), 800 V (d.c.)	

APPLICATION

This transformer has been designed to provide the required scanning amplitude for 31 cm (12 in) to 38 cm (15 in) 110° monochrome monitor tubes with a neck diameter of 28 mm in video display monitors presenting 625 lines at 50 frames per second (CCIR) or 525 lines at 60 frames per second (USA).

It is intended for use in conjunction with:

deflection unit AT1038/40A;

adjustable linearity control unit AT4042/08A;

line driver transformer AT4043/59;

e.h.t. cable with a length of 450 mm, catalogue number 3111 108 34160 or UL approved e.h.t.

cable, catalogue number 3111 108 34740.

DESCRIPTION

The magnetic circuit of the transformer comprises Ferroxcube U and I-cores, clamped together with two screws. The primary windings, the auxiliary windings and the e.h.t. winding are situated on one leg of the core, and are encapsulated in flame retardent polyester. An e.h.t. rectifier diode is incorporated in the transformer. The whole transformer meets the self-extinguishing and non-dripping properties of the American Underwriters' Laboratories rating mentioned in UL94SE-1.

The transformer is provided with four mounting pins; it can also be screwed to the printed-wiring board. External circuit connection is made to connecting pins, enabling the unit to be soldered directly into a printed-wiring board.

MECHANICAL DATA

Dimensions in mm

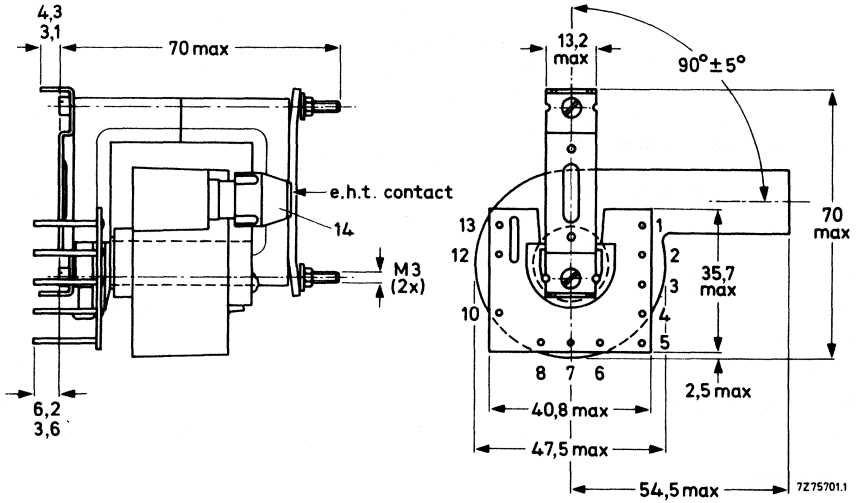

Fig. 1a Line output transformer AT2102/04C.

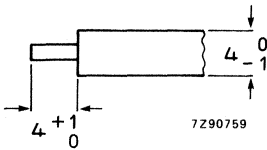

Fig. 1b E.H.T. contact (transformer side).

MOUNTING

The transformer may be mounted on a printed-wiring board. The fit of the connecting and mounting pins in a printed-wiring grid with a pitch of 2,54 mm (0,1 in) is illustrated in Fig. 2. The core of the transformer must be earthed.

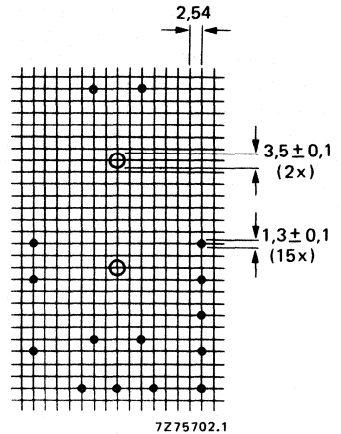

Fig. 2 Hole pattern for mounting on a printed-wiring board (solder side).

Temperature

The operating temperature of the core and the coils should not exceed 90 °C, under worst conditions, i.e. taking into account:

- over-voltage on the windings;
- low atmospheric pressure (at high altitudes) implying bad cooling by convection;
- high room temperature (up to 45 °C).

To satisfy this requirement it may be desired to provide ample cool air circulation around the transformer.

Distances

The following minimum distances between the transformer and neighbouring conductive flat surfaces must be maintained (in proportion to their sharpness protruding parts must have a greater distance):

- a. From the e.h.t. winding, radially 15 mm, axially 10 mm.
- b. From the e.h.t. lead 25 mm.

The transformer, and the leads and components carrying high-voltage pulses should be kept free from metal particles, solder drops etc.

ELECTRICAL DATA (see also Fig. 3)

E.H.T. supply	I_{eht} E.H.T. $R_{i(\text{eht})}$	0 μA 17 kV 6,5 M Ω	100 μA 16,35 kV
Power supply	V_{B} I_{av}	24 V 820 mA	24 V 910 mA
Output transistor	V_{CEM} I_{CM}	440 V 3,6 A	440 V 3,6 A
Deflection	Current Flyback time Overscan variation	4,6 A (p-p) 10,5 μs 1,5%	4,6 A (p-p) 10,5 μs

Auxiliary windings

- connecting pins 1 and 2 6,3 V (r.m.s.)
- connecting pin 4 (pin 5 connected to earth) 25 V (d.c.)
- connecting pin 3 (pin 5 connected to earth) 70 V (d.c.)
- connecting pin 7 (pin 6 connected to earth) 800 V (d.c.)

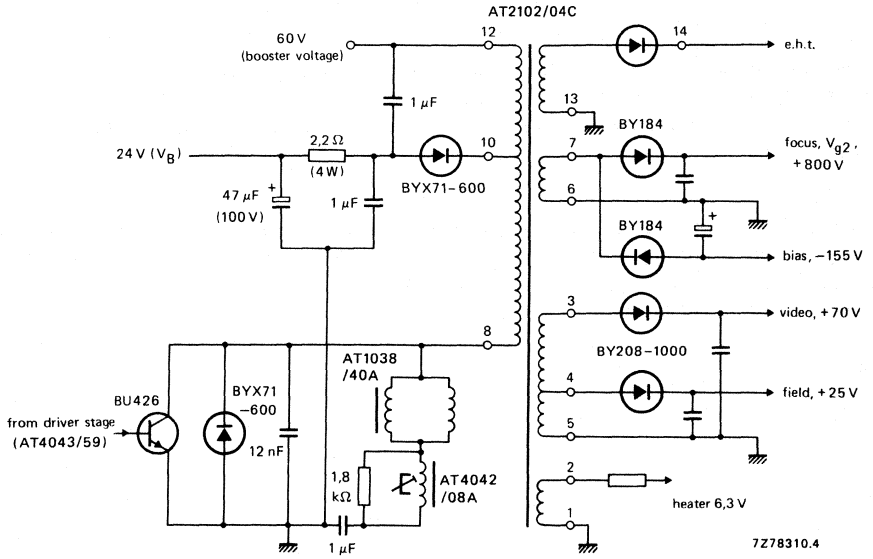

Fig. 3 Application circuit.

LINE OUTPUT TRANSFORMER

- For Monochrome Data Graphic Displays

QUICK REFERENCE DATA

I_{eht}	0 μA	100 μA
E.H.T.	17,0 kV	16,2 kV
$R_{\text{i(eht)}}$	8 $\text{M}\Omega$	
Supply voltage (V_{B})	24 V	
Supply current (I_{B})	955 mA	
Deflection current	4,4 A (p-p)	4,35 A (p-p)
Auxiliary voltages	6,4 V (r.m.s.), 87,6 V (d.c.), 905 V (d.c.), -144 V (d.c.)	

APPLICATION

This transformer has been designed to provide the required scanning amplitude for 31 cm (12 in) to 38 cm (15 in) 110° CRTs with a neck diameter of 28 mm in video display monitors.

The line frequency is set to 21,3 kHz at a fly-back time of 8,0 μs . With a small modification the line frequency can be reduced to 19 kHz. A frame frequency of 50 or 60 Hz is possible without modification.

The transformer is intended for use in conjunction with:

deflection unit AT1038/40A;

adjustable linearity control unit AT4042/08A;

line driver transformer AT4043/59;

e.h.t. cable with a length of 450 mm (catalogue number 3111 100 34160 or UL approved e.h.t. cable, catalogue number 3111 108 34740).

Note

The transformer was originally developed for data display of 80 characters per row, 28 rows per page, having a 7 x 9 character matrix in a 9 x 14 character cell; dynamic focusing was applied in the line direction to improve picture performance.

DESCRIPTION

The magnetic circuit of the transformer comprises two Ferroxcube U-cores, clamped together with two screws. The primary windings, the auxiliary windings and e.h.t. winding are situated on one leg of the core, and are encapsulated in flame retardant polyester. An e.h.t. rectifier diode is incorporated in the transformer. The whole transformer meets the self-extinguishing and non-dripping properties of the American Underwriters' Laboratories rating mentioned in UL94SE-1.

The transformer is provided with four mounting pins; it can also be screwed to the printed-wiring board. External circuit connection is made to connecting pins, enabling the unit to be soldered directly into a printed-wiring board.

MECHANICAL DATA

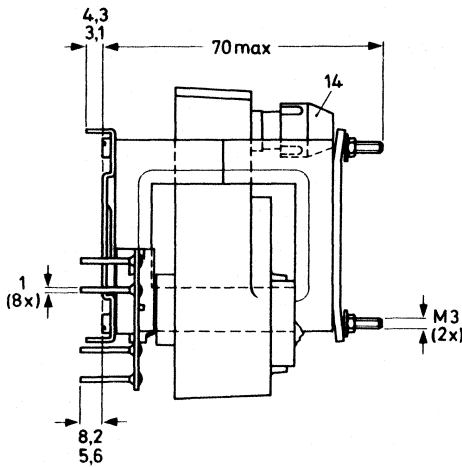

Dimensions in mm

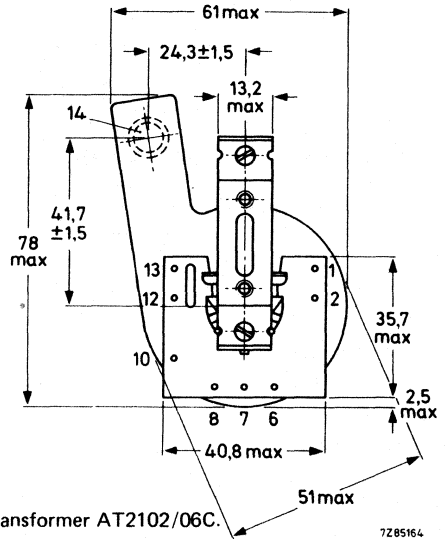
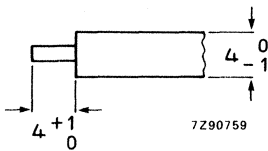

Fig. 1a Line output transformer AT2102/06C.

7Z85164



7Z90759

Fig. 1b E.H.T. contact (transformer side).

MOUNTING

The transformer may be mounted on a printed-wiring board. The fit of the connecting and mounting pins in a printed-wiring grid with a pitch of 2,54 mm (0,1 in) is illustrated in Fig. 2. The core of the transformer must be earthed.

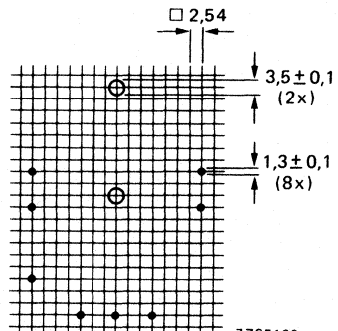

7Z85163

Fig. 2 Hole pattern for mounting on a printed-wiring board (solder side).

Temperature

The operating temperature of the core and the coils should not exceed 90 °C, under worst conditions, i.e. taking into account:

- over-voltage on the windings;
- low atmospheric pressure (at high altitudes) implying bad cooling by convection;
- high room temperature (up to 45 °C).

To satisfy this requirement it may be desired to provide ample cool air circulation around the transformer.

Distances

The following minimum distances between the transformer and neighbouring conductive flat surfaces must be maintained (in proportion to their sharpness protruding parts must have a greater distance):

- a. From the e.h.t. winding, radially 15 mm, axially 10 mm.
- b. In general such that no corona occurs at 10% over-voltage of e.h.t., at an air pressure of 60 kPa and a relative humidity of 85%.

The transformer, and the leads and components carrying high-voltage pulses should be kept free from metal particles, solder drops etc.

ELECTRICAL DATA (see also Fig. 3)

E.H.T. supply	I_{eht} E.H.T. $R_{\text{i(eht)}}$	0 μA 17,0 kV 8 M Ω	100 μA 16,2 kV
Power supply	V_{B} I_{B}	24 V 955 mA	
Output transistor	V_{CEM} I_{CM}	720 V 3,3 A	
Deflection	Current Flyback time Overscan variation (edge to edge)	4,4 A (p-p) 8,0 μs 0,5 %	

Auxiliary windings

connecting pins 1 and 2; load 300 mA	6,4 V (r.m.s.) \pm 5,5%
connecting pin 12; load 40 mA	87,6 V (d.c.)
connecting pin 7 (pin 6 connected to earth); load 0,7 mA	905 V (d.c.) \pm 5,5%
load 0,3 mA	-144 V (d.c.) \pm 5,5%

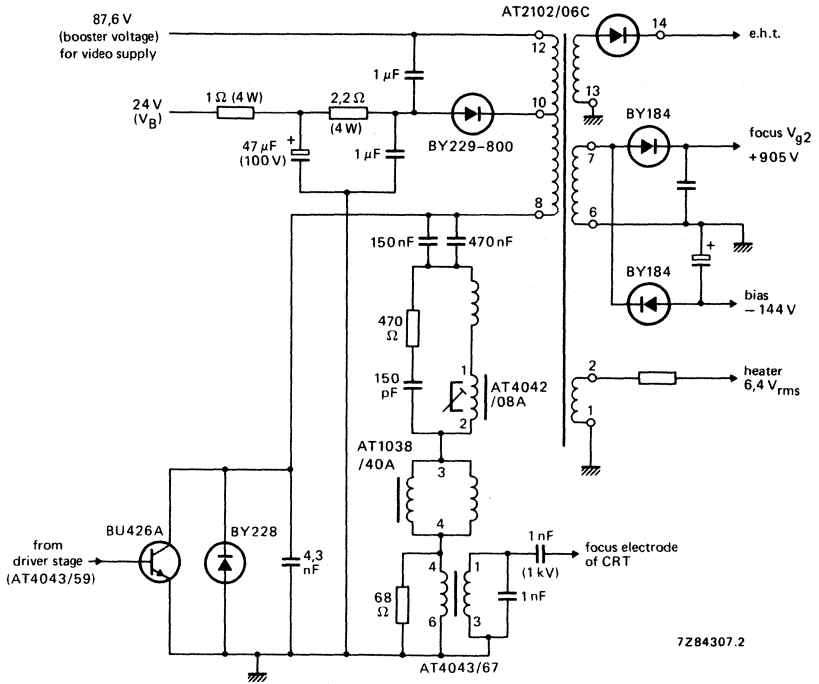

Fig. 3 Application circuit.

TESTS AND REQUIREMENTS

The line output transformer withstands the following tests.

IEC 68-2 test method	name of test	procedure (quick reference)
Ua1	Tensile strength of terminations	
Ub (method 1)	Bending of terminations	
Fc	Vibration	Frequency range 10-55-10 Hz, amplitude 0,35 mm, 3 directions, 30 min per direction
Eb	Bump	250 bumps in 5 directions, acceleration 25 g.
Ea	Shock	Half-sine pulse shape, 11 ms, 490 m/s ² , 6 directions, 3 shocks per direction.
Ta (method 1)	Soldering	Solder temp. 230 °C, dwell time 2 s.
Bb	Dry heat	96 h at +100 °C.
Db	Damp heat, cyclic	21 cycles of 24 h at +40 °C, R.H. 95%.
Ab	Cold	96 h at -25 °C.
M	Low air pressure	+55 °C, 60 kPa, 30 min.
Ca	Damp heat, steady state	21 days.
Na	Rapid change of temperature	5 cycles of -25 °C/+100 °C.
	Flammability of transformer (IEC65-14.4); power test	10 W, 20 W, 30 W and 40 W successively, for 2 min until encapsulation of e.h.t. coil cracks.
	Flammability of materials (UL94, class V1)	Line output transformer is self-extinguishing.

LINE OUTPUT TRANSFORMER

- For monochrome TV and inexpensive monitors

QUICK REFERENCE DATA

For transistor line output stages; 90° deflection angle

I_{eht}	$\leq 0,2 \text{ mA}$
E.H.T. at $I_{\text{B}} = 0 \mu\text{A}$	11,7 kV
$R_{\text{i}}(\text{eht})$	$\leq 7 \text{ M}\Omega$
Flyback time	11,1 μs
Line scan frequency	15 625 Hz
Deflection coil inductance	0,45 mH
Auxiliary voltages	+ 25 V, + 110 V, + 84,5 V

APPLICATION

This transformer has been designed to provide the required line scanning amplitude and e.h.t. for 90° monochrome picture tubes, presenting 625 lines at 50 fields per second (CCIR) or 525 lines at 60 fields per second (USA).

It is intended to be used in conjunction with e.h.t. cable, length 300 mm, catalogue number 3111 108 87080, or the UL approved type, catalogue number 3122 137 63920.

DESCRIPTION

The magnetic circuit of the transformer comprises two Ferroxcube U-cores. The primary windings, the auxiliary windings and e.h.t. winding are situated on one leg of the core, and are encapsulated in flame retardant polyester. An e.h.t. rectifier diode is incorporated in the transformer. The whole transformer meets the self-extinguishing requirements of IEC 65, para. 14.4.

External circuit connection is made to connecting pins, enabling the unit to be soldered directly into a printed-wiring board.

MECHANICAL DATA

Dimensions in mm

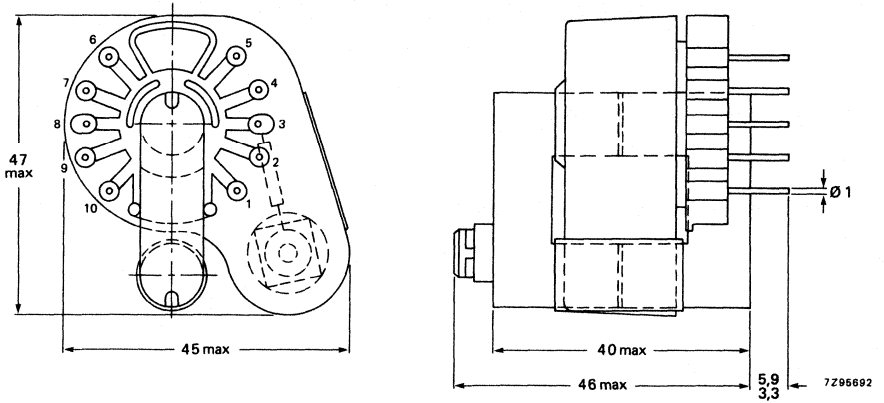

Fig. 1.

MOUNTING

The transformer may be mounted on a printed-wiring board. The fit of the connecting pins in a printed-wiring grid with a pitch of 2,54 mm (0,1 in) is illustrated in Fig. 2. The core of the transformer must be earthed.

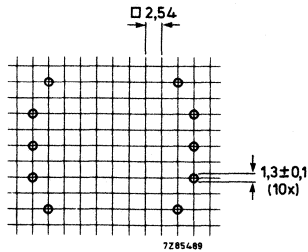

Fig. 2 Hole pattern for mounting on a printed-wiring board (solder side).

Temperature

The operating temperature of the core and the coils should not exceed 90 °C, under worst conditions, i.e. taking into account:

- over-voltage on the windings;
- low atmospheric pressure (at high altitudes) implying bad cooling by convection;
- high room temperature (up to 60 °C).

To satisfy this requirement it may be desired to provide ample cool air circulation around the transformer.

Distances

The following minimum distances between the transformer and neighbouring conductive flat surfaces must be maintained (in proportion to their sharpness protruding parts must have a greater distance):

from the e.h.t. winding, radially 15 mm, axially 10 mm.

The transformer, and the leads and components carrying high-voltage pulses should be kept free from metal particles, solder drops etc.

The bending radius of the e.h.t. cable must be $\geq 12,5$ mm.

ELECTRICAL DATA (see also Fig. 3)

E.H.T. at $I_B = 0 \mu A$	11,7 kV
$R_i(\text{eht})$	max. 7 M Ω
I_{eht}	max. 0,2 mA
Supply voltage (V_B)	11 V
Supply current	640 mA
Output transistor voltage, V_{CEM}	200 V _(p-p)
Deflection current	2,95 A _(p-p)
Flyback time	11,1 μs
Deflection coil inductance	0,45 mH
Line scan frequency	15625 Hz
Auxiliary voltages	
connecting pin 2, V_2	+ 25 V
connecting pin 6, V_6	+ 84,5 V
connecting pin 9, V_9	+ 110 V

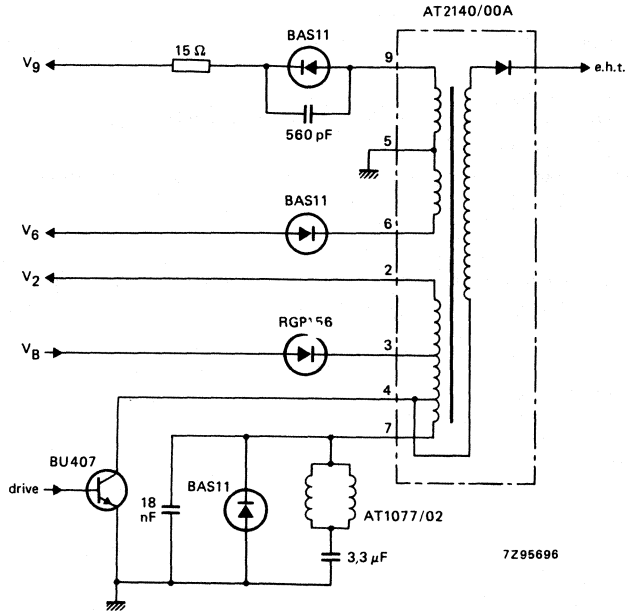

Fig. 3 Application circuit.

DEVELOPMENT DATA

This data sheet contains advance information and specifications are subject to change without notice.

AT2140/16
AT2140/17

Replaces AT2240/16

LINE OUTPUT TRANSFORMERS

- For Monochrome Data Graphic Displays

QUICK REFERENCE DATA

For transistor line output stages; 90° deflection angle

	AT2140/16	AT2140/17
I_{eht}	max. 100 μA	
E.H.T. at $I_{\text{B}} = 0 \mu\text{A}$	12,5 kV	12,5 kV
$R_{\text{i(eht)}}$	10 M Ω	
Flyback time	8 μs	6 μs
Line scan frequency range	15 to 23 kHz	22 to 30 kHz
Deflection coil inductance	475 μH	
Auxiliary voltages	+ 60 V (d.c.), -60 V (d.c.), + 500 V (d.c.)	

APPLICATION

These transformers have been designed to provide the required line scanning amplitude and e.h.t. for 90° monochrome data graphic display tubes, 20 mm neck diameter.

The transformers are intended for use in conjunction with:

- deflection unit AT1077 series,
- linearity control unit AT4042/08A,
- amplitude control unit AT4044/39D,
- e.h.t. cable, length 260 mm, catalogue number 3111 108 34490, or the UL approved type, catalogue number 3122 137 63920,
- dynamic focusing transformer AT4043/67.

DESCRIPTION

The magnetic circuit of the transformer comprises two Ferroxcube U-cores. The primary windings, the auxiliary windings and e.h.t. winding are situated on one leg of the core, and are encapsulated in flame retardant polyester. An e.h.t. rectifier diode is incorporated in the transformer. The whole transformer meets the self-extinguishing and non-dripping properties of the American Underwriters' Laboratories rating mentioned in UL94SE-1.

External circuit connection is made to connecting pins, enabling the unit to be soldered directly into a printed-wiring board.

MECHANICAL DATA

Dimensions in mm

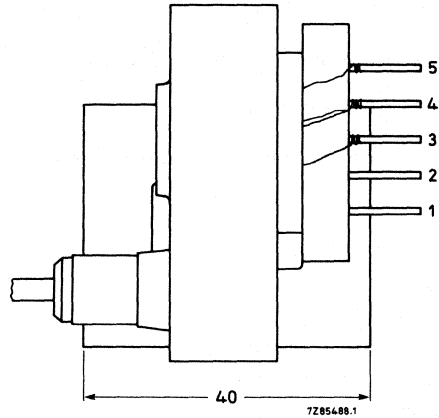
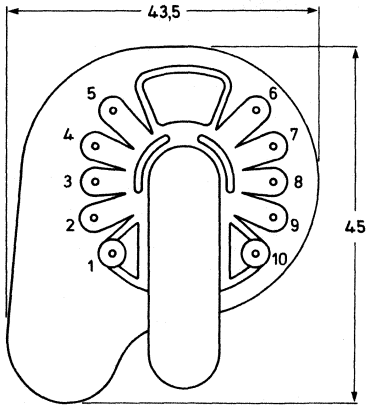

Fig. 1.

MOUNTING

The transformer may be mounted on a printed-wiring board. The fit of the connecting pins in a printed-wiring grid with a pitch of 2,54 mm (0,1 in) is illustrated in Fig. 2.

The core of the transformer must be earthed.

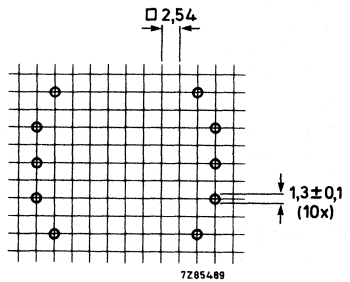

Fig. 2 Hole pattern for mounting on a printed-wiring board (solder side).

Temperature

The operating temperature of the core and the coils should not exceed 90 °C, under worst conditions, i.e. taking into account:

- over-voltage on the windings;
- low atmospheric pressure (at high altitudes) implying bad cooling by convection;
- high room temperature (up to 45 °C).

To satisfy this requirement it may be desired to provide ample cool air circulation around the transformer.

Distances

The following minimum distances between the transformer and neighbouring conductive flat surfaces must be maintained (in proportion to their sharpness protruding parts must have a greater distance):

- from the e.h.t. winding, radially 15 mm, axially 10 mm.

The transformer, and the leads and components carrying high-voltage pulses should be kept free from metal particles, solder drops etc.

The bending radius of the e.h.t. cable must be $\geq 7,5$ mm.

ELECTRICAL DATA (see also Fig. 3)

AT2140/16 and AT2140/17 used in conjunction with AT1077/05, AT4042/08A and AT4044/39D.

	AT2140/16	AT2140/17
Line scan frequency range*		
connecting pin 3	15 to 20 kHz	22 to 26 kHz
connecting pin 5	20 to 23 kHz	26 to 30 kHz
E.H.T. at $I_B = 0 \mu A$	12,5 kV	12,5 kV
$R_i(\text{eht})$	10 M Ω	10 M Ω
I_{eht}	max. 100 μA	max. 100 μA
Supply voltage (V_B)	11 to 14,5 V	11 to 14,5 V
Input power	7 W	10 W
Deflection current	2,9 A	2,9 A
Deflection voltage	300 V _(p-p)	450 V _(p-p)
Flyback time	8 μs	6 μs
Flyback capacitor	8,2 nF	5,6 nF
Auxiliary voltages		
connecting pin 1	+ 500 V	+ 500 V
connecting pin 7	+ 60 V	+ 60 V
connecting pin 10	-60 V	-60 V

For further information see Technical Publication "A low-cost monochrome data and graphics display unit (C6E)".

* The transformers are provided with two booster diode connections: pin 3 and pin 5, enabling selection of frequency ranges.

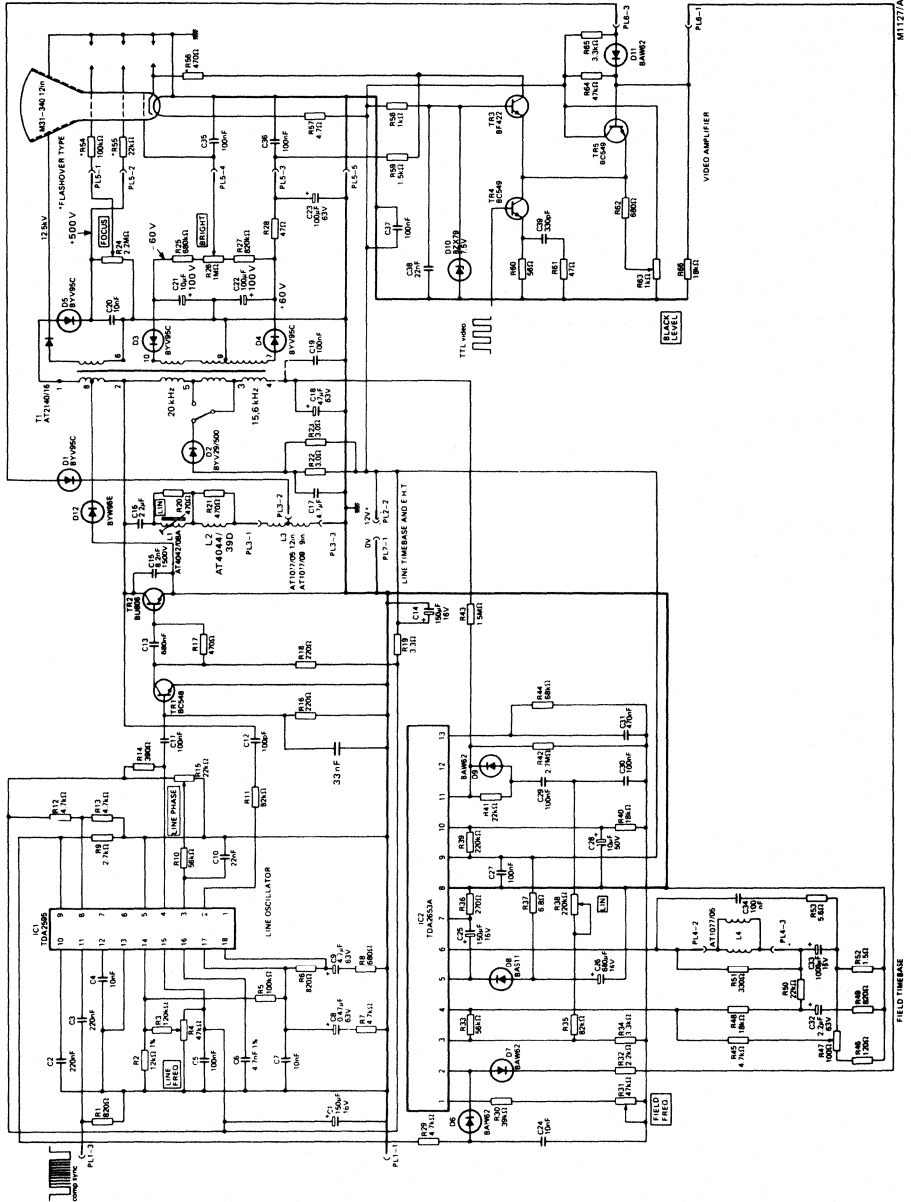

Fig. 3 Circuit diagram of data graphic display unit (C6E).

LINE OUTPUT TRANSFORMER

- For Monochrome Data Graphic Displays

QUICK REFERENCE DATA

I_{eht}	0 μA	100 μA
E.H.T	10,8 kV	10,0 kV
$R_{\text{i(eht)}}$	8 M Ω	
Supply voltage (V_{B})	12 V	
Supply current (I_{B})	390 mA	590 mA
Deflection current	2,7 A(p-p)	2,7 A(p-p)
Auxiliary voltages	11 V(r.m.s.), -70 V(d.c.), -165 V(d.c.), +450 V(d.c.)	

APPLICATION

This transformer has been designed to provide the required scanning amplitude for 24 cm (9 in) to 31 cm (12 in) 90° monochrome monitor tubes in video display monitors presenting 625 lines at 50 frames per second (CCIR) or 525 lines at 60 frames per second (USA).

It is intended for use in conjunction with deflection unit AT1077/..., linearity control unit AT4034/05A or linearity corrector AT4042/46, and an e.h.t. cable, length 260 mm, catalogue number 3111 100 32250, or the UL approved type, catalogue number 3122 137 63920.

DESCRIPTION

The magnetic circuit of the transformer comprises two Ferroxcube U-cores. The primary windings, the auxiliary windings and e.h.t. winding are situated on one leg of the core, and are encapsulated in flame retardant polyester. An e.h.t. rectifier diode is incorporated in the transformer. The whole transformer meets the self-extinguishing and non-dripping properties of the American Underwriters' Laboratories rating mentioned in UL94SE-1.

External circuit connection is made to connecting pins, enabling the unit to be soldered directly into a printed-wiring board.

MECHANICAL DATA

Dimensions in mm

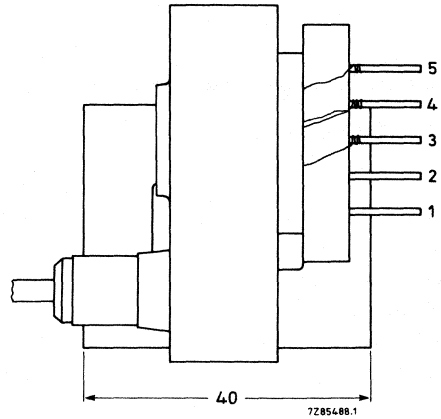
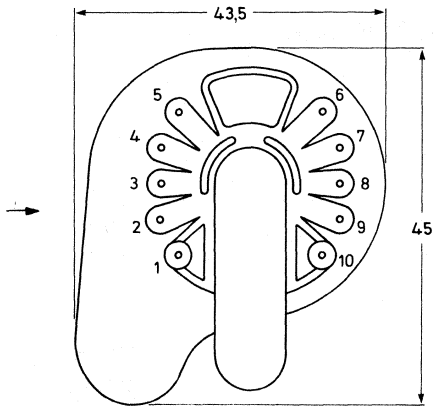

Fig. 1.

MOUNTING

The transformer may be mounted on a printed wiring board. The fit of the connecting pins in a printed-wiring grid with a pitch of 2,54 mm (0,1 in) is illustrated in Fig. 2.

The core of the transformer must be earthed.

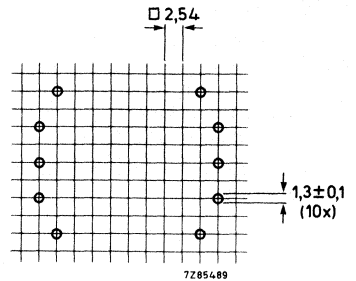

Fig. 2 Hole pattern for mounting on a printed-wiring board (solder side).

Temperature

The operating temperature of the core and the coils should not exceed 90 °C, under worst conditions, i.e. taking into account:

- over-voltage on the windings;
- low atmospheric pressure (at high altitudes) implying bad cooling by convection;
- high room temperature (up to 45 °C).

To satisfy this requirement it may be desired to provide ample cool air circulation around the transformer.

Distances

The following minimum distances between the transformer and neighbouring conductive flat surfaces must be maintained (in proportion to their sharpness protruding parts must have a greater distance):

- from the e.h.t. winding, radially 15 mm, axially 10 mm.

The transformer, and the leads and components carrying high-voltage pulses should be kept free from metal particles, solder drops etc.

The bending radius of the e.h.t. cable must be $\geq 7,5$ mm.

ELECTRICAL DATA (see also Fig. 3)

AT2140/16B used in conjunction with AT1077/05 and AT4042/46.

E.H.T. supply	I_{eht}	0 μA	100 μA
	E.H.T.	10,8 kV	10,4 kV
	$R_{i(eht)}$	8 M Ω	
Power supply	V_B	12 V	
	I_B	390 mA	480 mA
Output transistor	V_{CEM}	265 V	
	I_{CM}	2,3 A	
Deflection	Current	2,7 A(p-p)	
	Flyback time	8,5 μs	
Auxiliary windings			
connecting pin 1		-70 V(d.c.)	
connecting pin 4		-165 V(d.c.)	
connecting pins 6/8		11 V(r.m.s.)	
connecting pin 10		+450 V(d.c.)	

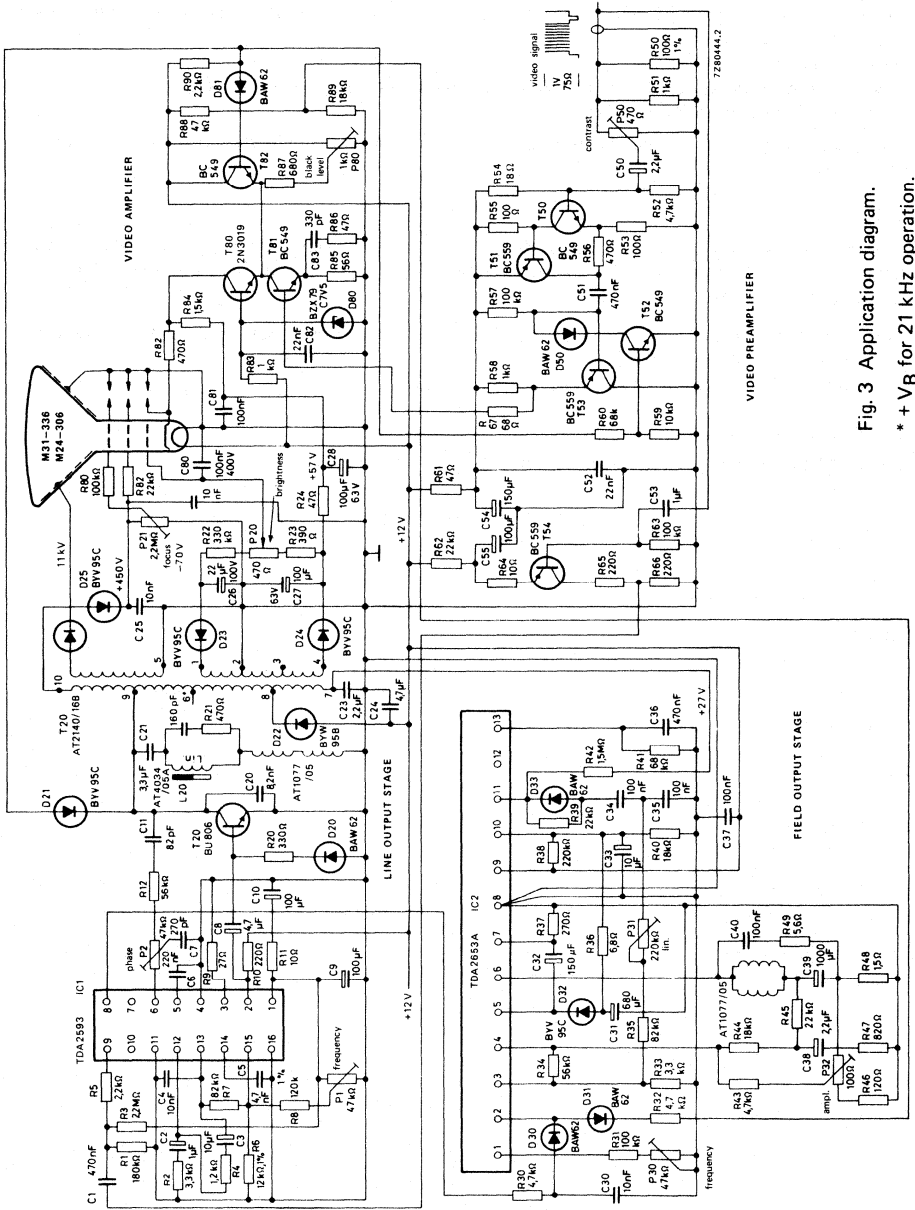

Fig. 3 Application diagram.
* + Vg for 21 kHz operation.

DEVELOPMENT DATA

This data sheet contains advance information and specifications are subject to change without notice.

AT2250/14

LINE OUTPUT TRANSFORMER

"Alpha box"

- For Monochrome Data Graphic Displays with 90° monitor tubes
- With or without built-in bleeder resistor

QUICK REFERENCE DATA

I_{eht}	max. 100 μ A
E.H.T. at $I_B = 0 \mu$ A	13 kV
$R_i(eht)$	max. 5 M Ω
Flyback time	4,2 μ s
Line frequency range	30 to 40 kHz
Deflection coil inductance	310 μ H
Auxiliary voltages	+ 60 V(d.c.), -60 V(d.c.), + 500 V(d.c.)

APPLICATION

This transformer has been designed to provide the required scanning amplitude and e.h.t. for 90° monochrome data graphic display tubes, 20 mm neck diameter, at line frequencies between 30 and 40 kHz.

It is intended for use in conjunction with:

- deflection unit AT1078 series;
- linearity control unit AT4042/08A;
- amplitude control unit AT4044/39D;
- dynamic focusing transformer AT4043/67;
- e.h.t. cable, catalogue number 3122 137 64830.

DESCRIPTION

The magnetic circuit of the transformer comprises two Ferroxcube U-cores. The primary windings, the auxiliary windings and e.h.t. windings are situated on one leg of the core, and are encapsulated in flame retardant epoxy resin. An e.h.t. rectifier diode is incorporated in the transformer. The whole transformer meets the self-extinguishing and non-dripping properties of the American Underwriter's Laboratories rating mentioned in UL94SE-1.

External circuit connection is made to connecting pins, enabling the unit to be soldered directly into a printed-wiring board; the e.h.t. has a plug connection.

The transformer is available with or without e.h.t. bleeder resistor.

MECHANICAL DATA

Dimensions in mm

Outlines

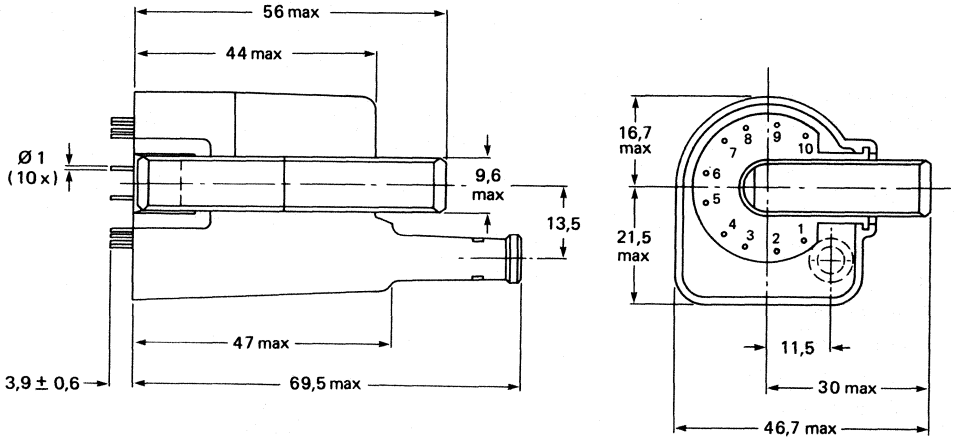

7295691

Fig. 1.

Mass approx. 130 g

Mounting

For mounting hole pattern see Fig. 2. The transformer core must be earthed.

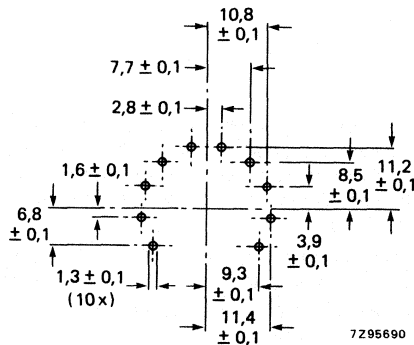

7295690

Fig. 2 Mounting hole pattern.

Temperature

The operating temperature of the core and the coils should not exceed 60 °C, under worst conditions, i.e. taking into account:

- over-voltage on the windings;
- low atmospheric pressure (at high altitudes) implying bad cooling by convection;
- high room temperature (up to 45 °C).

To satisfy this requirement it may be desired to provide ample cool air circulation around the transformer.

Distances

The minimum distance between the e.h.t. coil and neighbouring conductive flat surfaces is 5 mm.

Sharp edges of conductive parts must have a minimum distance of 10 mm.

The transformer, leads and components carrying high voltage pulses, should be kept free from metal particles, solder drops etc.

The bending radius of the e.h.t. cable must be $\geq 12,5$ mm.

ELECTRICAL DATA (see also Fig. 3)

AT2250/14 used in conjunction with AT1078/10, AT4042/08A and AT4044/39D.

Line scan frequency range	30 to 40 kHz
E.H.T. at $I_B = 0 \mu A$	13 kV
$R_i(\text{eht})$	$\leq 5 M\Omega$
I_{eht}	$\leq 100 \mu A$
Supply voltage (V_B)	38–55 V*
Input power	11 W
Deflection current	3,45 A
Deflection voltage	550 V (p-p)
Flyback time	4,2 μs
Flyback capacitor	3,3 nF
Auxiliary voltages (d.c.)	
connecting pin 1	+ 500 V
connecting pin 7	+ 60 V
connecting pin 10	–60 V

* Dependent on operating frequency.

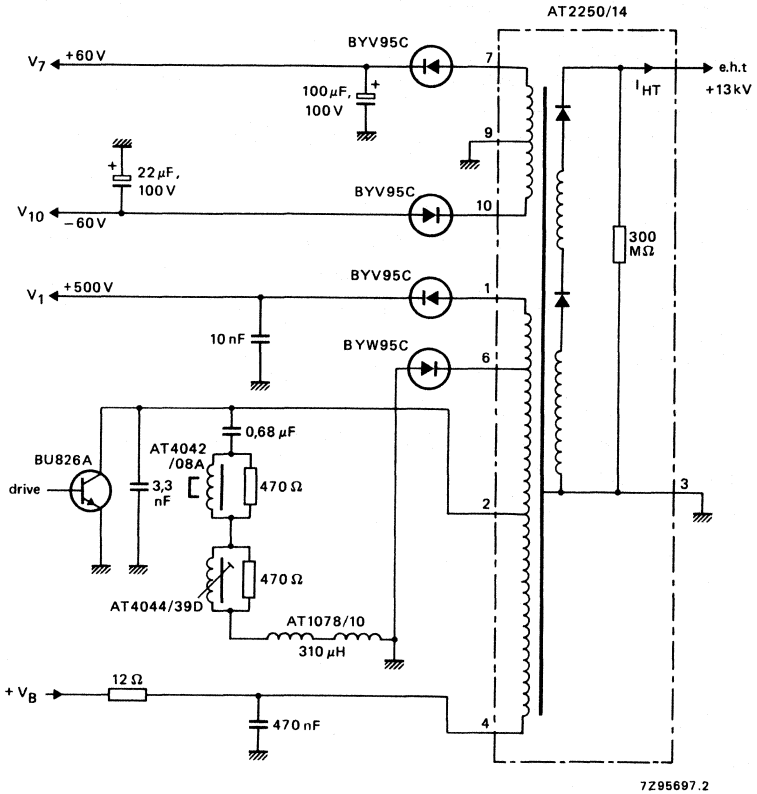

Fig. 3 Application circuit.

LINEARITY CORRECTORS

LINEARITY CORRECTOR

- For colour TV

APPLICATION

This linearity corrector is for the line deflection output stage of the 30AX system. It is compatible with linearity control unit AT4042/42 (connections 1 and 2 of the AT4042/42 on the printed-wiring board to be connected to 3 and 4 respectively).

DESCRIPTION

The linearity corrector consists of a coil, mounted on a Ferroxcube rod and a ring-shaped magnet of plastic-bonded Ferroxdure, which is placed around the rod at the bottom. The corrector has pins for mounting on a printed-wiring board.

MECHANICAL DATA

Dimensions in mm

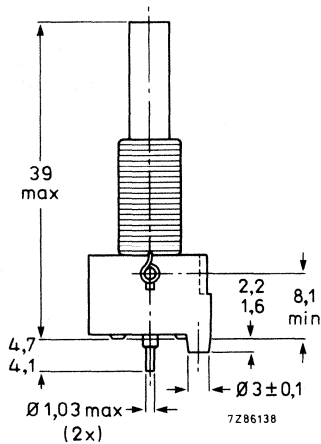
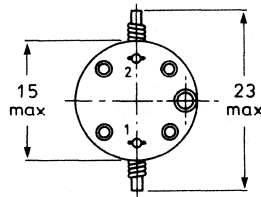

Fig. 1.

The linearity correctors are packed in boxes of 108 pieces.

Mounting

The AT4042/30 can be mounted on printed-wiring boards by means of its two connection pins, see Fig. 2. To prevent distortion of the magnetic field, no magnetic-conductive materials should approach the magnetic parts nearer than 3 mm. The coil should be shunted with a carbon resistor to damp ringing phenomena; the value of the resistor depends on the line output transformer used (typical value 560 Ω).

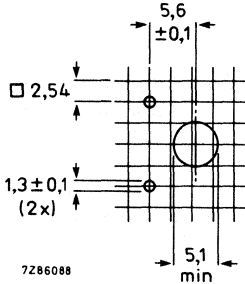

Fig. 2 Hole pattern for mounting on a printed-wiring board.

ELECTRICAL DATA

When a sawtooth current (without S-correction) of 5,1 A (p-p), frequency 15 625 Hz, flyback ratio 18%, flows through the linearity corrector, the correction voltage is 11,8 V ± 5,5%.

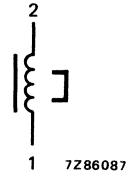

Fig. 3 Circuit diagram.

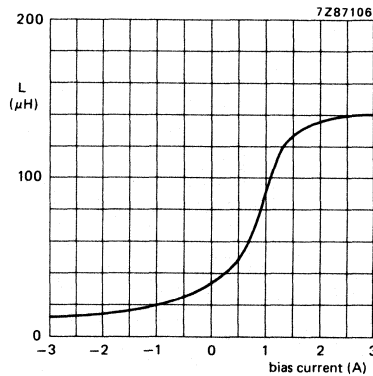

Fig. 4 Inductance as a function of bias current.

ENVIRONMENTAL DATA

Maximum ambient temperature	70 °C
Flammability of assembly	according to IEC 65, clause 14.4
Flammability of materials	according to UL94, category V-1

TESTS

The linearity corrector withstands the following tests:

Vibration	IEC 68-2-6, test Fc, procedure B4; 10-55-10 Hz, amplitude 0,35 mm, 3 x 30 min.
Bump	IEC 68-2-29, test Eb; 40g, 1000 bumps, 3 directions.
Soldering	IEC 68-2-20, test Ta, first part, method 1; 230 ± 10 °C, 2 ± 0,5 s.
Cold	IEC 68-2-1, test Aa; 96 h, -25 °C.
Dry heat	IEC 68-2-2, test Ba; 96 h, +100 °C.
Damp heat, cyclic	IEC 68-2-30, test Db; 21 days, +40 °C.
Damp heat, steady state	IEC 68-2-3, test Ca, 21 days.
Change of temperature	IEC 68-2-14, test Na; 5 cycles, T _A = -25 °C, T _B = +100 °C.

LINEARITY CORRECTOR

- For Colour Data Graphic Displays and Colour TV

APPLICATION

This linearity corrector is for the line deflection output stage of 90° colour monitors and TV receivers.

DESCRIPTION

The linearity corrector consists of a coil, mounted on a Ferroxcube rod and a ring-shaped magnet of plastic-bonded Ferroxidure, which is placed around the rod at the bottom.

The corrector has pins for mounting on a printed-wiring board.

MECHANICAL DATA

Dimensions in mm

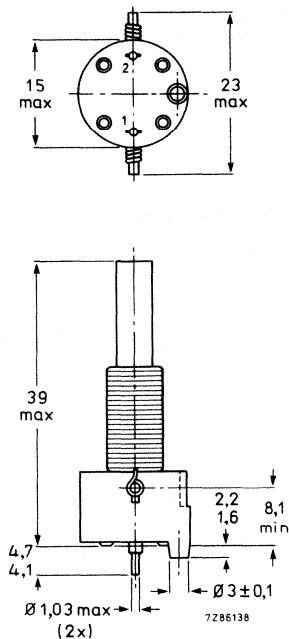

Fig. 1.

The linearity correctors are packed in boxes of 108 pieces.

Mounting .

The AT4042/34 can be mounted on printed-wiring boards by means of its two connection pins, see Fig. 2. To prevent distortion of the magnetic field, no magnetic-conductive materials should approach the magnetic parts nearer than 3 mm. The coil should be shunted with a carbon resistor to damp ringing phenomena; the value of the resistor depends on the line output transformer used (typical value 560 Ω).

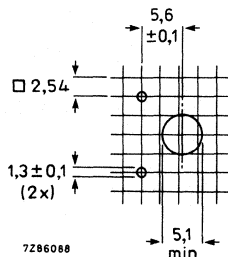

Fig. 2 Hole pattern for mounting on a printed-wiring board.

ELECTRICAL DATA

When a sawtooth current (without S-correction) of 3,0 A (p-p), frequency 15 625 Hz, flyback ratio 18%, flows through the linearity corrector, the correction voltage is 15,2 V \pm 5,5%.

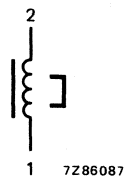

Fig. 3 Circuit diagram.

Reliability

Maximum cumulative percentage catastrophic failures	
after 3000 h	\leq 0,05%
after 10 000 h	\leq 0,2%
after 30 000 h	\leq 5%

ENVIRONMENTAL DATA

Maximum ambient temperature	70 °C
Flammability of assembly	according to IEC 65, clause 14.4
Flammability of materials	according to UL94, category V-1

TESTS

The linearity corrector withstands the following tests:

Vibration	IEC 68-2-6, test Fc, procedure B4; 10-55-10 Hz; amplitude 0,35 mm, 3 x 30 min.
Bump	IEC 68-2-29, test Eb; 40 g, 1000 bumps, 3 directions.
Soldering	IEC 68-2-20, test Ta, first part, method 1; 230 \pm 10 °C, 2 \pm 0,5 s.
Cold	IEC 68-2-1, test Aa; 96 h, -25 °C.
Dry heat	IEC 68-2-2, test Ba; 96 h, + 100 °C.
Damp heat, cyclic	IEC 68-2-30, test Db; 21 days, + 40 °C.
Damp heat, steady state	IEC 68-2-3, test Ca, 21 days.
Change of temperature	IEC 68-2-14, test Na; 5 cycles, T _A = -25 °C, T _B = + 100 °C.

LINEARITY CORRECTOR

- For Colour TV

APPLICATION

This linearity corrector is for the line deflection output stage of colour TV receivers and 90° monitors.

DESCRIPTION

The linearity corrector consists of a coil, mounted on a Ferroxcube rod and a ring-shaped magnet of plastic-bonded Ferroxidure, which is placed around the rod at the bottom. The corrector has pins for mounting on a printed-wiring board.

MECHANICAL DATA

Dimensions in mm

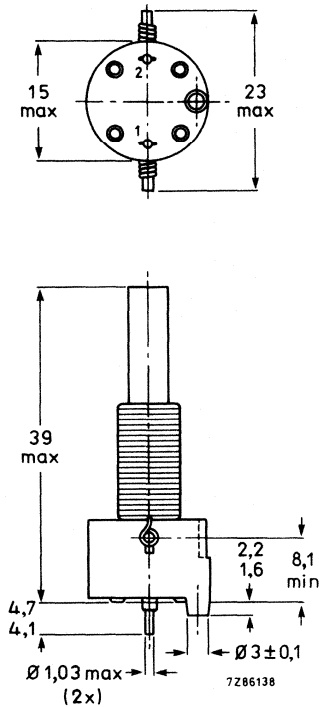

Fig. 1.

The linearity correctors are packed in boxes of 108 pieces.

Mounting

The AT4042/36FS can be mounted on printed-wiring boards by means of its two connection pins, see Fig. 2. To prevent distortion of the magnetic field, no magnetic-conductive materials should approach the magnetic parts nearer than 3 mm. The coil should be shunted with a carbon resistor to damp ringing phenomena; the value of the resistor depends on the line output transformer used (typical value 560 Ω).

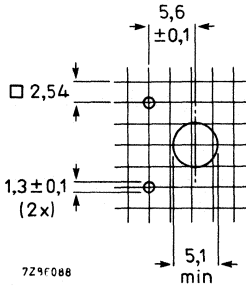

Fig. 2 Hole pattern for mounting on a printed-wiring board.

ELECTRICAL DATA

When a sawtooth current (without S-correction) of 1,9 A (p-p), frequency 15 625 Hz, flyback ratio 18%, flows through the linearity corrector, the correction voltage is 17,4 V ± 5,5%.

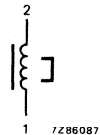

Fig. 3 Circuit diagram.

ENVIRONMENTAL DATA

- Maximum ambient temperature 70 °C
- Flammability of assembly according to IEC 65, clause 14.4
- Flammability of materials according to UL94, category V-1

TESTS

The linearity corrector withstands the following tests:

- Vibration IEC 68-2-6, test Fc, procedure B4; 10-55-10 Hz, amplitude 0,35 mm, 3 x 30 min.
- Bump IEC 68-2-29, test Eb; 40g, 1000 bumps, 3 directions.
- Soldering IEC 68-2-20, test Ta, first part, method 1; 230 ± 10 °C, 2 ± 0,5 s.
- Cold IEC 68-2-1, test Aa; 96 h, -25 °C.
- Dry heat IEC 68-2-2, test Ba; 96 h, + 100 °C.
- Damp heat, cyclic IEC 68-2-30, test Db; 21 days, + 40 °C.
- Damp heat, steady state IEC 68-2-3, test Ca, 21 days.
- Change of temperature IEC 68-2-14, test Na; 5 cycles, T_A = -25 °C, T_B = + 100 °C.

LINEARITY CORRECTOR

- For colour TV

APPLICATION

This linearity corrector is for the line deflection output stage of 90° colour TV receivers and monitors.

DESCRIPTION

The linearity corrector consists of a coil, mounted on a Ferroxcube rod and a ring-shaped magnet of plastic-bonded Ferroxdure, which is placed around the rod at the bottom. The corrector has pins for mounting on a printed-wiring board.

MECHANICAL DATA

Dimensions in mm

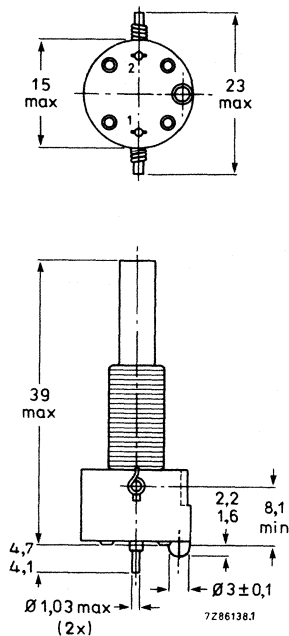

Fig. 1.

The linearity correctors are packed in boxes of 108 pieces.

Mounting

The AT4042/41FS can be mounted on printed-wiring boards by means of its two connection pins, see Fig. 2. To prevent distortion of the magnetic field, no magnetic-conductive materials should approach the magnetic parts nearer than 3 mm. The coil should be shunted with a carbon resistor to damp ringing phenomena; the value of the resistor depends on the line output transformer used (typical value 560 Ω).

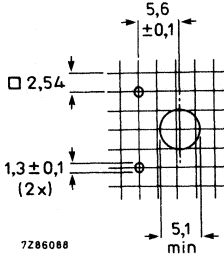

Fig. 2 Hole pattern for mounting on a printed-wiring board.

ELECTRICAL DATA

When a sawtooth current (without S-correction) of 2,1 A (p-p), frequency 15 625 Hz, flyback ratio 18%, flows through the linearity corrector, the correction voltage is 12,7 V ± 5,5%.

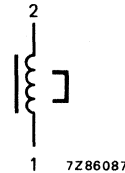

Fig. 3 Circuit diagram.

Reliability

Maximum cumulative percentage catastrophic failures	
after 300 h	≤ 0,05%
after 10 000 h	≤ 0,2%
after 30 000 h	≤ 5%

ENVIRONMENTAL DATA

Maximum ambient temperature	70 °C
Flammability of assembly	according to IEC 65, clause 14.4
Flammability of materials	according to UL94, category V-1

TESTS

The linearity corrector withstands the following tests:

Vibration	IEC 68-2-6, test Fc, procedure B4; 10-55-10 Hz, amplitude 0,35 mm, 3 x 30 min.
Bump	IEC 68-2-29, test Eb; 40g, 1000 bumps, 3 directions.
Soldering	IEC 68-2-20, test Ta, first part, method 1; 230 ± 10 °C, 2 ± 0,5 s.
Cold	IEC 68-2-1, test Aa; 96 h, -25 °C.
Dry heat	IEC 68-2-2, test Ba; 96 h, + 100 °C.
Damp heat, cyclic	IEC 68-2-30, test Db; 21 days, + 40 °C.
Damp heat, steady state	IEC 68-2-3, test Ca, 21 days.
Change of temperature	IEC 68-2-14, test Na; 5 cycles, T _A = -25 °C, T _B = + 100 °C.

LINEARITY CORRECTOR

- For Monochrome Data Graphic Displays.

APPLICATION

This linearity corrector is for the line deflection output stage of 90° monitors for data graphic display in conjunction with line output transformer AT2140/16B or AT2240/16, and deflection unit AT1077/05.

DESCRIPTION

The linearity corrector consists of a coil, mounted on a Ferroxcube rod and a ring-shaped magnet of plastic-bonded Ferroxdure, which is placed around the rod at the bottom.

The corrector has pins for mounting on a printed-wiring board.

MECHANICAL DATA

Dimensions in mm

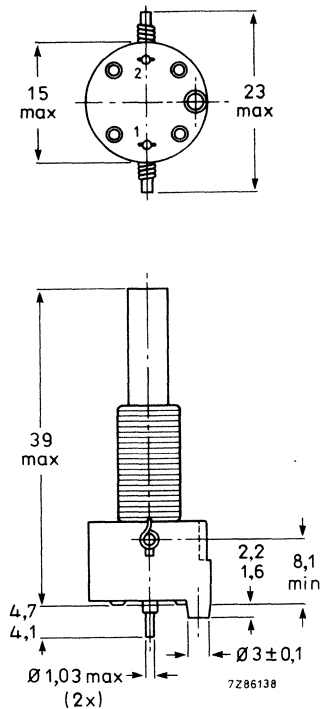

Fig. 1.

Mounting

The AT4042/46 can be mounted on printed-wiring boards by means of its two connection pins, see Fig. 2. To prevent distortion of the magnetic field, no magnetic-conductive materials should approach the magnetic parts nearer than 3 mm. The coil should be shunted with a carbon resistor to damp ringing phenomena; the value of the resistor depends on the line output transformer used (typical value 560Ω).

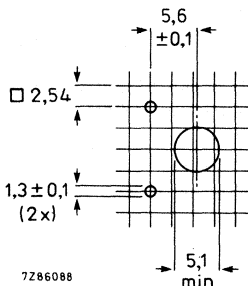

Fig. 2 Hole pattern for mounting on a printed-wiring board.

ELECTRICAL DATA

When a sawtooth current (without S-correction) of 3 A (p-p), frequency 15 625 Hz, flyback ratio 18%, flows through the linearity corrector, the correction voltage is $6 \text{ V} \pm 5,5\%$.

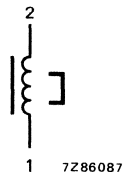

Fig. 3 Circuit diagram.

TESTS

The linearity corrector withstands the following tests:

Vibration	IEC 68-2-6, test Fc, procedure B4; 10-55-10 Hz, amplitude 0,35 mm, 3 x 30 min.
Bump	IEC 68-2-29, test Eb; 40g, 1000 bumps, 3 directions.
Soldering	IEC 68-2-20, test Ta, first part, method 1; $230 \pm 10 \text{ }^\circ\text{C}$, $2 \pm 0,5 \text{ s}$.
Cold	IEC 68-2-1, test Aa; 96 h, $-25 \text{ }^\circ\text{C}$.
Dry heat	IEC 68-2-2, test Ba; 96 h, $+100 \text{ }^\circ\text{C}$.
Damp heat, cyclic	IEC 68-2-30, test Db; 21 days, $+40 \text{ }^\circ\text{C}$.
Damp heat, steady state	IEC 68-2-3, test Ca, 21 days.
Change of temperature	IEC 68-2-14, test Na; 5 cycles, $T_A = -25 \text{ }^\circ\text{C}$, $T_B = +100 \text{ }^\circ\text{C}$.
Flammability of assembly	IEC 65, clause 14.4.
Flammability of materials	UL94, category V1.

LINEARITY CORRECTOR

- For colour TV

APPLICATION

This linearity corrector is for the line deflection output stage of the 45AX system.

DESCRIPTION

The linearity corrector consists of a coil, mounted on a Ferroxcube rod and a ring-shaped magnet of plastic-bonded Ferroxdure, which is placed around the rod at the bottom. The corrector has pins for mounting on a printed-wiring board.

MECHANICAL DATA

Dimensions in mm

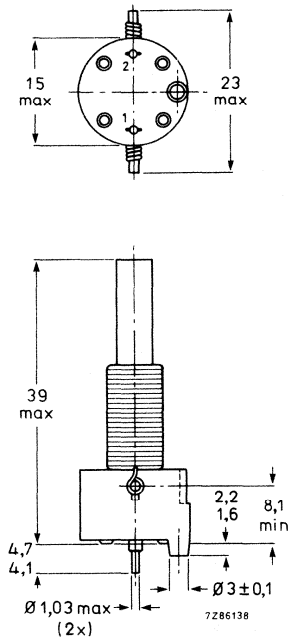

Fig. 1.

The linearity correctors are packed in boxes of 108 pieces.

Mounting

The AT4042/51 can be mounted on printed-wiring boards by means of its two connection pins, see Fig. 2. To prevent distortion of the magnetic field, no magnetic-conductive materials should approach the magnetic parts nearer than 3 mm. The coil should be shunted with a carbon resistor to damp ringing phenomena; the value of the resistor depends on the line output transformer used (typical value 560 Ω).

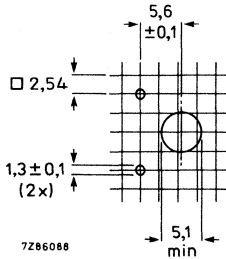

Fig. 2 Hole pattern for mounting on a printed-wiring board.

ELECTRICAL DATA

When a sawtooth current (without S-correction) of 3,15 A (p-p), frequency 15 625 Hz, flyback ratio 18%, flows through the linearity corrector, the correction voltage is 12,9 V ± 5,5%.

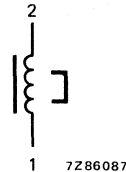

Fig. 3 Circuit diagram.

Reliability

Maximum cumulative percentage catastrophic failures

after 300 h	≤ 0,05%
after 10 000 h	≤ 0,2%
after 30 000 h	≤ 5%

ENVIRONMENTAL DATA

Maximum ambient temperature	70 °C
Flammability of assembly	according to IEC 65, clause 14.4
Flammability of materials	according to UL94, category V-1

TESTS

The linearity corrector withstands the following tests:

Vibration	IEC 68-2-6, test Fc, procedure B4; 10-55-10 Hz, amplitude 0,35 mm, 3 x 30 min.
Bump	IEC 68-2-29, test Eb; 40g, 1000 bumps, 3 directions.
Soldering	IEC 68-2-20, test Ta, first part, method 1; 230 ± 10 °C, 2 ± 0,5 s.
Cold	IEC 68-2-1, test Aa; 96 h, -25 °C.
Dry heat	IEC 68-2-2, test Ba; 96 h, + 100 °C.
Damp heat, cyclic	IEC 68-2-30, test Db; 21 days, + 40 °C.
Damp heat, steady state	IEC 68-2-3, test Ca, 21 days.
Change of temperature	IEC 68-2-14, test Na; 5 cycles, T _A = -25 °C, T _B = + 100 °C.

LINEARITY CORRECTOR

- For colour Data Graphic Displays and Colour TV

APPLICATION

This linearity corrector is for the line deflection output stage of 90° monitors and TV receivers.

DESCRIPTION

The linearity corrector consists of a coil, mounted on a Ferroxcube rod and a ring-shaped magnet of plastic-bonded Ferroxidure, which is placed around the rod at the bottom. The corrector has pins for mounting on a printed-wiring board.

MECHANICAL DATA

Dimensions in mm

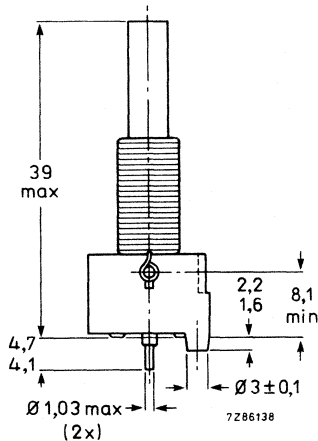
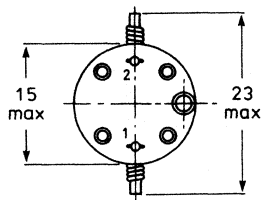

The linearity correctors are packed in boxes of 108 pieces.

Mounting

The AT4042/90 can be mounted on printed-wiring boards by means of its two connection pins, see Fig. 2. To prevent distortion of the magnetic field, no magnetic-conductive materials should approach the magnetic parts nearer than 3 mm. The coil should be shunted with a carbon resistor to damp ringing phenomena; the value of the resistor depends on the line output transformer used (typical value 560 Ω).

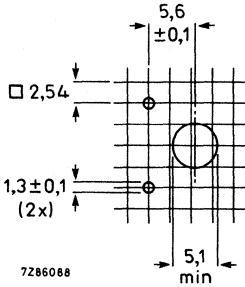

Fig. 2 Hole pattern for mounting on a printed-wiring board.

ELECTRICAL DATA

When a sawtooth current (without S-correction) of 2,9 A (p-p), frequency 15 625 Hz, flyback ratio 18%, flows through the linearity corrector, the correction voltage is $9,8 V \pm 5,5\%$.

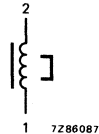

Fig. 3 Circuit diagram.

ENVIRONMENTAL DATA

- Maximum ambient temperature 70 °C
- Flammability of assembly according to IEC 65, clause 14.4
- Flammability of materials according to UL94, category V-1

TESTS

The linearity corrector withstands the following tests:

- Vibration IEC 68-2-6, test Fc, procedure B4; 10-55-10 Hz, amplitude 0,35 mm, 3 x 30 min.
- Bump IEC 68-2-29, test Eb; 40g, 1000 bumps, 3 directions.
- Soldering IEC 68-2-20, test Ta, first part, method 1; 230 ± 10 °C, $2 \pm 0,5$ s.
- Cold IEC 68-2-1, test Aa; 96 h, -25 °C.
- Dry heat IEC 68-2-2, test Ba; 96 h, + 100 °C.
- Damp heat, cyclic IEC 68-2-30, test Db; 21 days, + 40 °C.
- Damp heat, steady state IEC 68-2-3, test Ca, 21 days.
- Change of temperature IEC 68-2-14, test Na; 5 cycles, $T_A = -25$ °C, $T_B = + 100$ °C.

LINEARITY CORRECTOR

- For colour TV

APPLICATION

This linearity corrector is for 90° minineck applications.

DESCRIPTION

The linearity corrector consists of a coil, mounted on a Ferroxcube rod and a ring-shaped magnet of plastic-bonded Ferroxdure, which is placed around the rod at the bottom. The corrector has pins for mounting on a printed-wiring board.

MECHANICAL DATA

Dimensions in mm

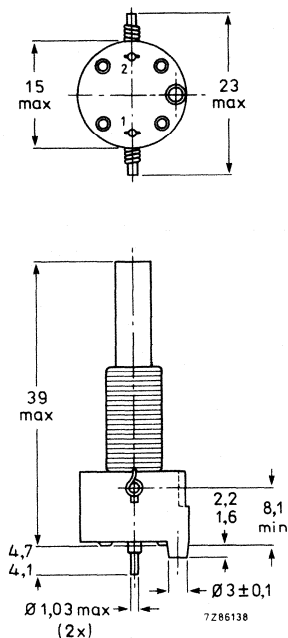

Fig. 1.

The linearity correctors are packed in boxes of 108 pieces.

Mounting

The AT4042/91 can be mounted on printed-wiring boards by means of its two connection pins, see Fig. 2. To prevent distortion of the magnetic field, no magnetic-conductive materials should approach the magnetic parts nearer than 3 mm. The coil should be shunted with a carbon resistor to damp ringing phenomena; the value of the resistor depends on the line output transformer used (typical value 560 Ω).

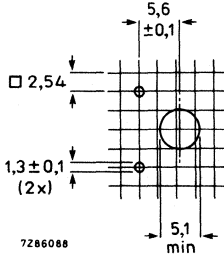

Fig. 2 Hole pattern for mounting on a printed-wiring board.

ELECTRICAL DATA

When a sawtooth current (without S-correction) of 2,3 A (p-p), frequency 15 625 Hz, flyback ratio 18%, flows through the linearity corrector, the correction voltage is 17,6 V ± 5%.

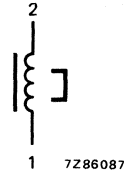

Fig. 3 Circuit diagram.

Reliability

Maximum cumulative percentage catastrophic failures

after 300 h	≤ 0,05%
after 10 000 h	≤ 0,2%
after 30 000 h	≤ 5%

ENVIRONMENTAL DATA

Maximum ambient temperature	70 °C
Flammability of assembly	according to IEC 65, clause 14.4
Flammability of materials	according to UL94, category V-1

TESTS

The linearity corrector withstands the following tests:

Vibration	IEC 68-2-6, test Fc, procedure B4; 10-55-10 Hz, amplitude 0,35 mm, 3 x 30 min.
Bump	IEC 68-2-29, test Eb; 40g, 1000 bumps, 3 directions.
Soldering	IEC 68-2-20, test Ta, first part, method 1; 230 ± 10 °C, 2 ± 0,5 s.
Cold	IEC 68-2-1, test Aa; 96 h, -25 °C.
Dry heat	IEC 68-2-2, test BA; 96 h, + 100 °C.
Damp heat, cyclic	IEC 68-2-30, test Db; 21 days, + 40 °C.
Damp heat, steady state	IEC 68-2-3, test Ca; 21 days.
Change of temperature	IEC 68-2-14, test Na; 5 cycles, T _A = -25 °C, T _B = + 100 °C.

LINEARITY CORRECTOR

- For colour TV

APPLICATION

This linearity corrector is for the line deflection output stage of colour TV receivers.

DESCRIPTION

The linearity corrector consists of a coil, mounted on a Ferroxcube rod and a ring-shaped magnet of plastic-bonded Ferroxdure, which is placed around the rod at the bottom.

The corrector has pins for mounting on a printed-wiring board.

MECHANICAL DATA

Dimensions in mm

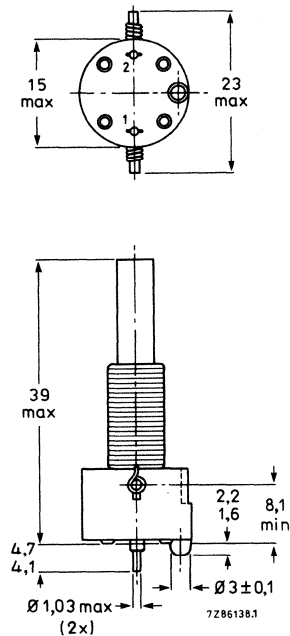

Fig. 1.

The linearity correctors are packed in boxes of 108 pieces.

Mounting

The AT4042/92 can be mounted on printed-wiring boards by means of its two connection pins, see Fig. 2. To prevent distortion of the magnetic field, no magnetic-conductive materials should approach the magnetic parts nearer than 3 mm. The coil should be shunted with a carbon resistor to damp ringing phenomena; the value of the resistor depends on the line output transformer used (typical value 560 Ω).

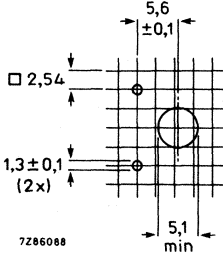

Fig. 2 Hole pattern for mounting on a printed-wiring board.

ELECTRICAL DATA

When a sawtooth current (without S-correction) of 5,5 A (p-p), frequency 15 625 Hz, flyback ratio 18%, flows through the linearity corrector, the correction voltage is 14,7 V ± 5%.

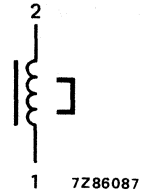

Fig. 3 Circuit diagram.

Reliability

Maximum cumulative percentage catastrophic failures	
after 300 h	≤ 0,05%
after 10 000 h	≤ 0,2%
after 30 000 h	≤ 5%

ENVIRONMENTAL DATA

Maximum ambient temperature	70 °C
Flammability of assembly	according to IEC 65, clause 14.4
Flammability of materials	according to UL94, category V-1

TESTS

The linearity corrector withstands the following tests:

Vibration	IEC 68-2-6, test Fc, procedure B4; 10-55-10 Hz, amplitude 0,35 mm, 3 x 30 min.
Bump	IEC 68-2-29, test Eb; 40g, 1000 bumps, 3 directions.
Soldering	IEC 68-2-20, test Ta, first part, method 1; 230 ± 10 °C, 2 ± 0,5 s.
Cold	IEC 68-2-1, test Aa; 96 h, -25 °C.
Dry heat	IEC 68-2-2, test Ba; 96 h, + 100 °C.
Damp heat, cyclic	IEC 68-2-30, test Db; 21 days, + 40 °C.
Damp heat, steady state	IEC 68-2-3, test Ca; 21 days.
Change of temperature	IEC 68-2-14, test Na; 5 cycles, T _A = -25 °C, T _B = + 100 °C.

LINEARITY CONTROL UNITS

Replaces AT4036

ADJUSTABLE LINEARITY CONTROL UNIT

- For monochrome Data Graphic Displays

APPLICATION

This linearity control unit is for use in monochrome monitors.

DESCRIPTION

The unit consists of a coil, mounted on a Ferroxcube rod, and two Ferroxdure magnets. One ring-shaped magnet is placed around the Ferroxcube rod, at the bottom. The other magnet is positioned against the Ferroxcube rod opposite the bottom magnet and clamped. It is provided with a square hole to facilitate adjustment of the biasing field and, therefore, the linearity of the line deflection.

MECHANICAL DATA; Dimensions in mm

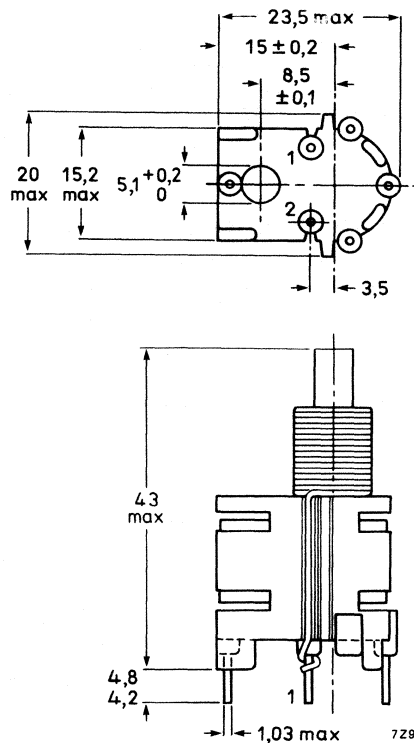

Fig. 1.

The linearity control units are packed in boxes of 300 pieces.

Mounting

The unit can be mounted on printed-wiring boards by means of its two connection pins, see Fig. 2. To prevent distortion of the magnetic field, no magnetic-conductive materials should approach the magnetic parts nearer than 3 mm. The coils should be shunted with a carbon resistor to damp ringing phenomena; the value of the resistor depends on the line output transformer used (typical value 560 Ω).

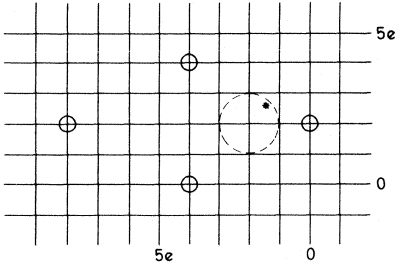

Fig. 2 Hole pattern for mounting on a printed-wiring board. Grid hole diameter = $1,3 \pm 0,1$ mm; $e = 2,54$ mm.

ELECTRICAL DATA

When a sawtooth current (without S-correction) of 6,0 A (p-p), frequency 16 kHz, flyback ratio 18%, flows through the linearity control unit, the correction voltage is adjustable between 0,95 and 2,15 V \pm 10%.

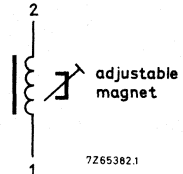

Fig. 3 Circuit diagram.

ENVIRONMENTAL DATA

- Maximum ambient temperature 70 °C
- Flammability of assembly according to IEC 65, clause 14.4
- Flammability of materials according to UL94, category V-1

TESTS

The linearity control unit withstands the following tests:

- Vibration IEC 68-2-6, test Fc, procedure B4; 10-55-10 Hz, amplitude 0,35 mm, 3 x 30 min.
- Bump IEC 68-2-29, test Eb; 40 g, 1000 bumps, 3 directions.
- Soldering IEC 68-2-20, test Ta, first part, method 1; 230 \pm 10 °C, 2 \pm 0,5 s.
- Cold IEC 68-2-1, test Aa; 96 h, -25 °C.
- Dry heat IEC 68-2-2, test Ba; 96 h, + 100 °C.
- Damp heat cyclic IEC 68-2-30, test Db; 21 days, + 40 °C.
- Damp heat, steady state IEC 68-2-3, test Ca, 21 days.
- Change of temperature IEC 68-2-14, test Na; 5 cycles, T_A = -25 °C, T_B = + 100 °C.

Replaces AT4042/02
and AT4042/04P

ADJUSTABLE LINEARITY CONTROL UNIT

- For Colour Data Graphic Displays

APPLICATION

This linearity control unit is for use in colour monitors. It can also be used in 90° colour and monochrome television sets.

DESCRIPTION

The unit consists of a coil, mounted on a Ferroxcube rod, and three Ferroxdure magnets. Two ring-shaped magnets are placed around the Ferroxcube rod, one at the top and one at the bottom. The third magnet is positioned against the Ferroxcube rod opposite the bottom magnet and clamped. It is provided with a square hole to facilitate adjustment of the biasing field and, therefore, the linearity of the line deflection.

MECHANICAL DATA; Dimensions in mm

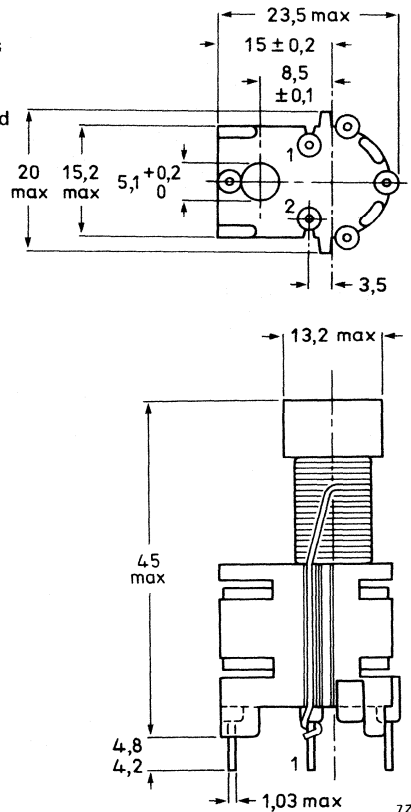

Fig. 1.

7295277

The linearity control units are packed in boxes of 300 pieces.

Mounting

The unit can be mounted on printed-wiring boards by means of its two connection pins, see Fig. 2. To prevent distortion of the magnetic field, no magnetic-conductive materials should approach the magnetic parts nearer than 3 mm. The coils should be shunted with a carbon resistor to damp ringing phenomena; the value of the resistor depends on the line output transformer used (typical value 560 Ω).

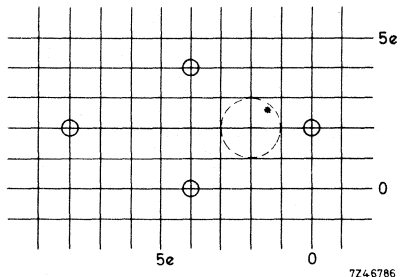

Fig. 2 Hole pattern for mounting on a printed-wiring board. Grid hole diameter = 1,3 ± 0,1 mm; e = 2,54 mm.

ELECTRICAL DATA

When a sawtooth current (without S-correction) of 2,8 A (p-p), frequency 16 kHz, flyback ratio 18%, flows through the linearity control unit, the correction voltage is adjustable between 12,5 and 29 V ± 10%.

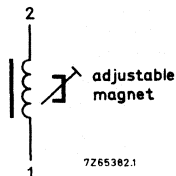

Fig. 3 Circuit diagram.

ENVIRONMENTAL DATA

Maximum ambient temperature	70 °C
Flammability of assembly	according to IEC 65, clause 14.4
Flammability of materials	according to UL94, category V-1

TESTS

The linearity control unit withstands the following tests:

Vibration	IEC 68-2-6, test Fc, procedure B4; 10-55-10 Hz, amplitude 0,35 mm, 3 x 30 min.
Bump	IEC 68-2-29, test Eb; 40g, 1000 bumps, 3 directions.
Soldering	IEC 68-2-20, test Ta, first part, method 1; 230 ± 10 °C, 2 ± 0,5 s.
Cold	IEC 68-2-1, test Aa; 96 h, -25 °C.
Dry heat	IEC 68-2-2, test Ba; 96 h, + 100 °C.
Damp heat, cyclic	IEC 68-2-30, test Db; 21 days, + 40 °C.
Damp heat, steady state	IEC 68-2-3, test Ca, 21 days.
Change of temperature	IEC 68-2-14, test Na; 5 cycles, T _A = -25 °C, T _B = + 100 °C.

Replaces AT4042/42
and AT4042/08

ADJUSTABLE LINEARITY CONTROL UNIT

- For monochrome Data Graphic Displays

APPLICATION

This linearity control unit is for use in monochrome monitors. It is used in conjunction with a deflection unit of the AT1039 series, with series connected line coils.

DESCRIPTION

The unit consists of a coil, mounted on a Ferroxcube rod, and three Ferroxdure magnets. Two ring-shaped magnets are placed around the Ferroxcube rod, one at the top and one at the bottom. The third magnet is positioned against the Ferroxcube rod opposite the bottom magnet and clamped. It is provided with a square hole to facilitate adjustment of the biasing field and, therefore, the linearity of the line deflection.

MECHANICAL DATA; Dimensions in mm

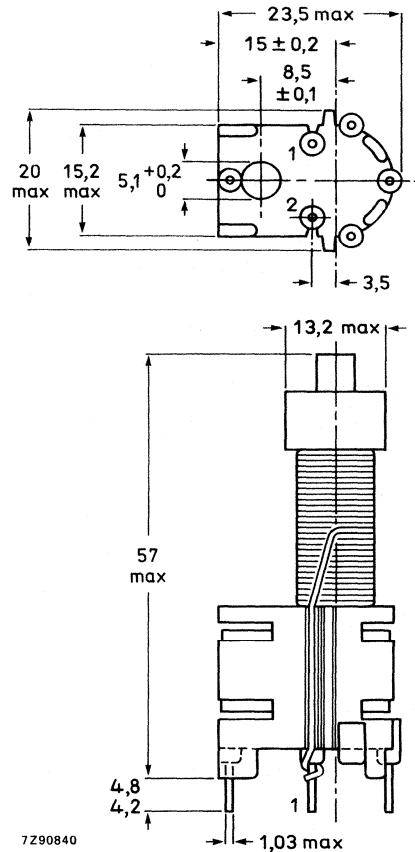

Fig. 1.

7290840

The linearity control units are packed in boxes of 300 pieces.

Mounting

The unit can be mounted on printed-wiring boards by means of its two connection pins, see Fig. 2. To prevent distortion of the magnetic field, no magnetic-conductive materials should approach the magnetic parts nearer than 3 mm. The coils should be shunted with a carbon resistor to damp ringing phenomena; the value of the resistor depends on the line output transformer used (typical value 560 Ω).

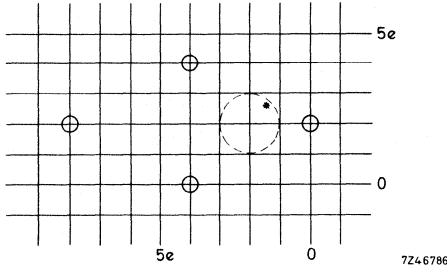

Fig. 2 Hole pattern for mounting on a printed-wiring board. Grid hole diameter = $1,3 \pm 0,1$ mm; $e = 2,54$ mm (0,1 in).

ELECTRICAL DATA

When a sawtooth current (without S-correction) of 6,0 A (p-p), frequency 16 kHz, flyback ratio 18%, flows through the linearity control unit, the correction voltage is adjustable between 15 and 25 V \pm 10%.

Note: With a sawtooth current of 4,65 A (p-p) the correction voltage is adjustable between 8 and 15 V.

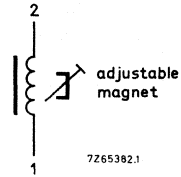

Fig. 3 Circuit diagram.

ENVIRONMENTAL DATA

Maximum ambient temperature	70 °C
Flammability of assembly	according to IEC 65, clause 14.4
Flammability of materials	according to UL94, category V-1

TESTS

The linearity control unit withstands the following tests:

Vibration	IEC 68-2-6, test Fc, procedure B4; 10-55-10 Hz, amplitude 0,35 mm, 3 x 30 min.
Bump	IEC 68-2-29, test Eb; 40g, 1000 bumps, 3 directions.
Soldering	IEC 68-2-20, test Ta, first part, method 1; 230 \pm 10 °C, 2 \pm 0,5 s.
Cold	IEC 68-2-1, test Aa; 96 h, -25 °C.
Dry heat	IEC 68-2-2, test Ba; 96 h, + 100 °C.
Damp heat, cyclic	IEC 68-2-30, test Db; 21 days, + 40 °C.
Damp heat, steady state	IEC 68-2-3, test Ca, 21 days.
Change of temperature	IEC 68-2-14, test Na; 5 cycles, T _A = 25 °C, T _B = + 100 °C.

ADJUSTABLE LINEARITY CONTROL UNIT

- For Colour Data Graphic Displays

APPLICATION

This linearity control unit is for use in colour monitors.

DESCRIPTION

The unit consists of a coil, mounted on a Ferroxcube rod, and three Ferrodure magnets. Two ring-shaped magnets are placed around the Ferroxcube rod, one at the top and one at the bottom. The third magnet is positioned against the Ferroxcube rod opposite the bottom magnet and clamped. It is provided with a square hole to facilitate adjustment of the biasing field and, therefore, the linearity of the line deflection.

MECHANICAL DATA

Outlines; Dimensions in mm

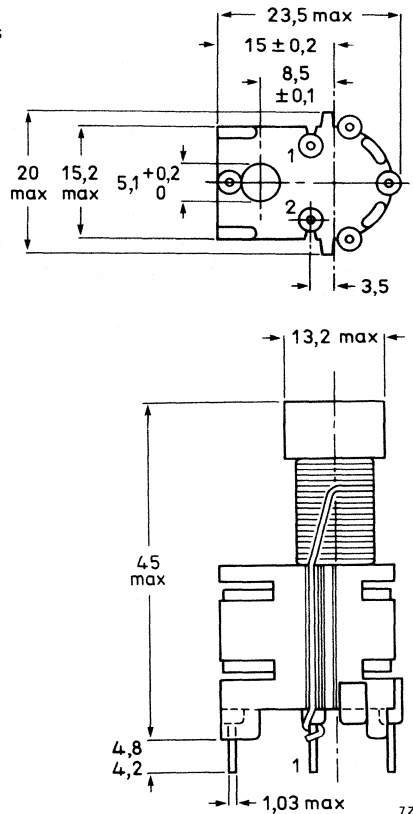

Fig. 1.

The linearity control units are packed in boxes of 300 pieces.

Mounting

The unit can be mounted on printed-wiring boards by means of its two connection pins, see Fig. 2. To prevent distortion of the magnetic field, no magnetic-conductive materials should approach the magnetic parts nearer than 3 mm. The coils should be shunted with a carbon resistor to damp ringing phenomena; the value of the resistor depends on the line output transformer used (typical value 560 Ω).

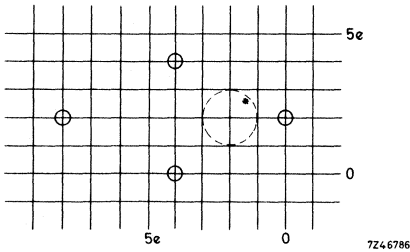

Fig. 2 Hole pattern for mounting on a printed-wiring board ($e = 2,54 \text{ mm}$ (0,1 in)); grid hole diameter $1,3 \pm 0,1 \text{ mm}$.

* Hole for bottom adjustment.

ELECTRICAL DATA

When a sawtooth current (with S-correction) of 4,4 A (p-p), frequency 32 kHz, flyback ratio 18%, flows through the linearity control unit, the correction voltage is adjustable between 0,65 and 3,2 V $\pm 10\%$.

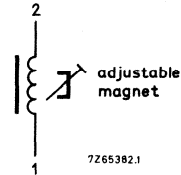

Fig. 3 Circuit diagram.

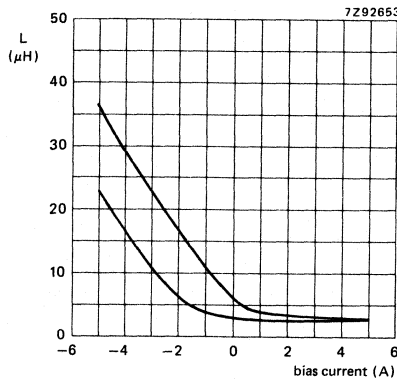

Fig. 4 Inductance as a function of bias current.

ENVIRONMENTAL DATA

Maximum ambient temperature	70 °C
Flammability of assembly	according to IEC 65, clause 14.4
Flammability of materials	according to UL94, category V-1

TESTS

The linearity control unit withstands the following tests:

Vibration	IEC 68-2-6, test Fc, procedure B4; 10-55-10 Hz, amplitude 0,35 mm, 3 x 30 min.
Bump	IEC 68-2-29, test Eb, 40g. 1000 bumps, 3 directions.
Soldering	IEC 68-2-20, test Ta, first part, method 1; 230 ± 10 °C, 2 ± 0,5 s.
Cold	IEC 68-2-1, test Aa; 96 h, -25 °C.
Dry heat	IEC 68-2-2, test Ba; 96 h, + 100 °C.
Damp heat, cyclic	IEC 68-2-30, test Db, test Db; 21 days, + 40 °C.
Damp heat, steady state	IEC 68-2-3, test Ca, 21 days.
Change of temperature	IEC 68-2-14, test Na; 5 cycles, T _A = -25 °C, T _B = + 100 °C.

ADJUSTABLE LINEARITY CONTROL UNIT

- For monochrome Data Graphic Displays

APPLICATION

This linearity control unit is for use in monochrome monitors. It is used in conjunction with a deflection unit of the AT1039 series, and line output transformer AT2076/84.

DESCRIPTION

The unit consists of a coil, mounted on a Ferroxcube rod, and three Ferrodure magnets. Two ring-shaped magnets are placed around the Ferroxcube rod, one at the top and one at the bottom. The third magnet is positioned against the Ferroxcube rod opposite the bottom magnet and clamped. It is provided with a square hole to facilitate adjustment of the biasing field and, therefore, the linearity of the line deflection.

MECHANICAL DATA; Dimensions in mm

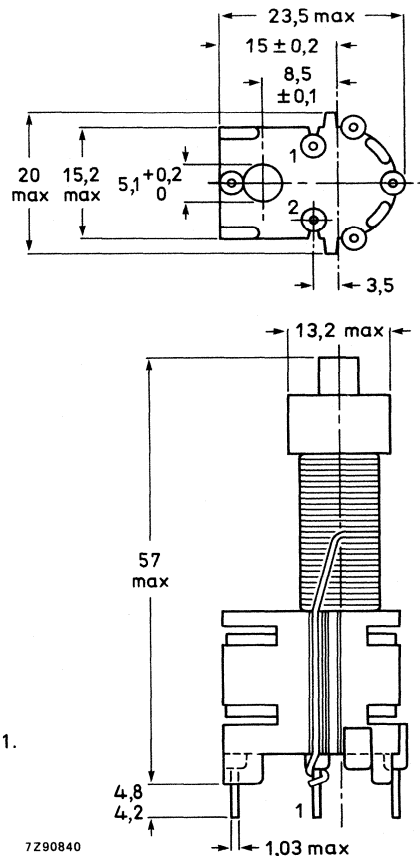

The linearity control units are packed in boxes of 300 pieces.

Mounting

The unit can be mounted on printed-wiring boards by means of its two connection pins, see Fig. 2. To prevent distortion of the magnetic field, no magnetic-conductive materials should approach the magnetic parts nearer than 3 mm. The coils should be shunted with a carbon resistor to damp ringing phenomena; the value of the resistor depends on the line output transformer used (typical value 560 Ω).

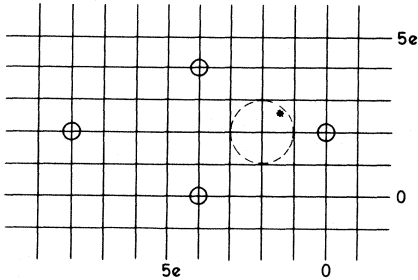

7Z4.6786

Fig. 2 Hole pattern for mounting on a printed-wiring board; e = 2,54 mm.

ELECTRICAL DATA

When a sawtooth current (without S-correction) of 8,8 A (p-p), frequency 32 kHz, flyback ratio 18%, flows through the linearity control unit, the correction voltage is adjustable between 6 and 10 V.

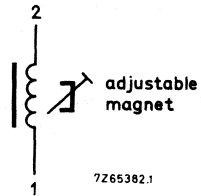

Fig. 3 Circuit diagram.

ENVIRONMENTAL DATA

- Maximum ambient temperature 70 °C
- Flammability of assembly according to IEC 65, clause 14.4
- Flammability of materials according to UL94, category V-1

TESTS

The linearity control unit withstands the following tests:

- Vibration IEC 68-2-6, test Fc, procedure B4; 10-55-10 Hz, amplitude 0,35 mm, 3 x 30 min.
- Bump IEC 68-2-29, test Eb; 40g, 1000 bumps, 3 directions.
- Soldering IEC 68-2-20, test Ta, first part, method 1; 230 ± 10 °C, 2 ± 0,5 s.
- Cold IEC 68-2-1, test Aa; 96 h, -25 °C.
- Dry heat IEC 68-2-2, test Ba; 96 h, +100 °C.
- Damp heat, cyclic IEC 68-2-30, test Db; 21 days, +40 °C.
- Damp heat, steady state IEC 68-2-3, test Ca, 21 days.
- Change of temperature IEC 68-2-14, test Na; 5 cycles, T_A = -25 °C, T_B = +100 °C.

ADJUSTABLE LINEARITY CONTROL UNIT

- For Colour Data Graphic Displays and Colour TV

APPLICATION

This linearity control unit is for use in colour monitors and television sets.

DESCRIPTION

The unit consists of a coil, mounted on a Ferroxcube rod, and three Ferroxidure magnets. Two ring-shaped magnets are placed around the Ferroxcube rod, one at the top and one at the bottom. The third magnet is positioned against the Ferroxcube rod opposite the bottom magnet and clamped. It is provided with a square hole to facilitate adjustment of the biasing field and, therefore, the linearity of the line deflection.

MECHANICAL DATA; Dimensions in mm

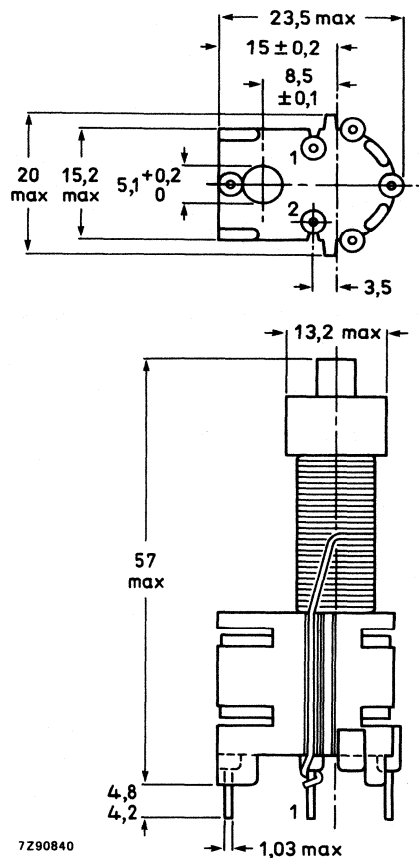

Fig. 1.

7290840

The linearity control units are packed in boxes of 300 pieces.

Mounting

The unit can be mounted on printed-wiring boards by means of its two connection pins, see Fig. 2. To prevent distortion of the magnetic field, no magnetic-conductive materials should approach the magnetic parts nearer than 3 mm. The coils should be shunted with a carbon resistor to damp ringing phenomena; the value of the resistor depends on the line output transformer used (typical value 560 Ω).

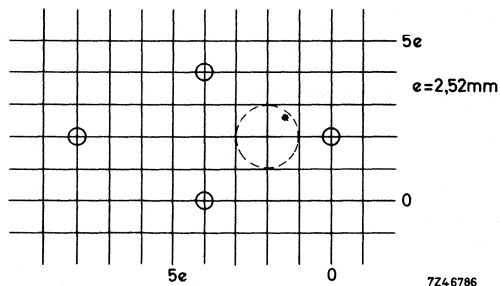

Fig. 2 Hole pattern for mounting on a printed-wiring board; $e = 2,54$ mm.

* Hole for bottom adjustment.

ELECTRICAL DATA

When a sawtooth current (without S-correction) of 6,0 A (p-p), frequency 16 kHz, flyback ratio 18%, flows through the linearity control unit, the correction voltage is adjustable between 8,5 and 12,4 V.

Reliability

Maximum cumulative percentage catastrophic failures	
after 300 h	$\leq 0,05\%$
after 10 000 h	$\leq 0,2\%$
after 30 000 h	$\leq 5\%$

ENVIRONMENTAL DATA

Maximum ambient temperature	70 °C
Flammability of assembly	according to IEC 65, clause 14.4
Flammability of materials	according to UL94, category V-1

TESTS

The linearity control unit withstands the following tests:

Vibration	IEC 68-2-6, test Fc, procedure B4; 10-55-10 Hz, amplitude 0,35 mm, 3 x 30 min.
Bump	IEC 68-2-29, test Eb; 40g, 1000 bumps, 3 directions.
Soldering	IEC 68-2-20, test Ta, first part, method 1; 230 \pm 10 °C, 2 \pm 0,5 s.
Cold	IEC 68-2-1, test Aa; 96 h, -25 °C.
Dry heat	IEC 68-2-2, test Ba; 96 h, + 100 °C.
Damp heat, cyclic	IEC 68-2-30, test Db; 21 days, + 40 °C.
Damp heat, steady state	IEC 68-2-3, test Ca, 21 days.
Change of temperature	IEC 68-2-14, test Na; 5 cycles, $T_A = -25$ °C, $T_B = + 100$ °C.

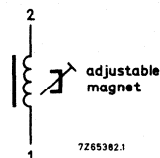

Fig. 3 Circuit diagram.

ADJUSTABLE LINEARITY CONTROL UNIT

- For Colour Data Graphic Displays and Colour TV

APPLICATION

This linearity control unit is for use in colour monitors and television sets.

DESCRIPTION

The unit consists of a coil, mounted on a Ferroxcube rod, and three Ferrodure magnets. Two ring-shaped magnets are placed around the Ferroxcube rod, one at the top and one at the bottom. The third magnet is positioned against the Ferroxcube rod opposite the bottom magnet and clamped. It is provided with a square hole to facilitate adjustment of the biasing field and, therefore, the linearity of the line deflection.

MECHANICAL DATA; Dimensions in mm

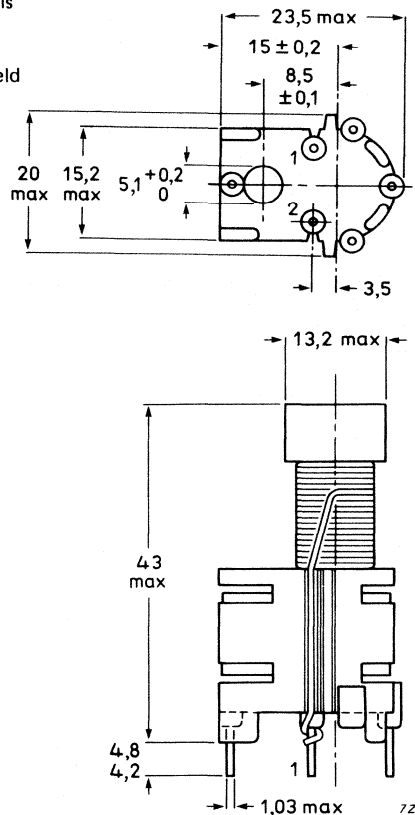

Fig. 1.

The linearity control units are packed in boxes of 300 pieces.

Mounting

The unit can be mounted on printed-wiring boards by means of its two connection pins, see Fig. 2. To prevent distortion of the magnetic field, no magnetic-conductive materials should approach the magnetic parts nearer than 3 mm. The coils should be shunted with a carbon resistor to damp ringing phenomena; the value of the resistor depends on the line output transformer used (typical value 560 Ω).

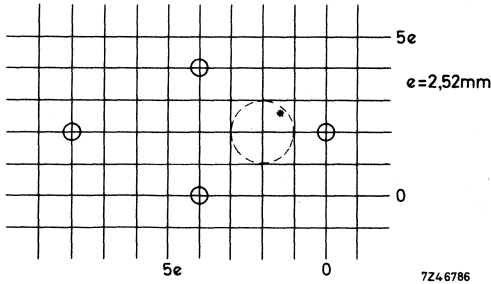

Fig. 2 Hole pattern for mounting on a printed-wiring board; e = 2,54 mm.

* Hole for bottom adjustment.

ELECTRICAL DATA

When a sawtooth current (without S-correction) of 8,5 A (p-p), frequency 32 kHz, flyback ratio 18%, flows through the linearity control unit, the correction voltage is adjustable between 2,4 and 6,5 V.

Reliability

Maximum cumulative percentage catastrophic failures	
after 300 h	≤ 0,05%
after 10 000 h	≤ 0,2%
after 30 000 h	≤ 5%

ENVIRONMENTAL DATA

Maximum ambient temperature	70 °C
Flammability of assembly	according to IEC 65, clause 14.4
Flammability of materials	according to UL94, category V-1

TESTS

The linearity control unit withstands the following tests:

Vibration	IEC 68-2-6, test Fc, procedure B4; 10-55-10 Hz, amplitude 0,35 mm, 3 x 30 min.
Bump	IEC 68-2-29, test Eb; 40g, 1000 bumps, 3 directions.
Soldering	IEC 68-2-20, test Ta, first part, method 1; 230 ± 10 °C, 2 ± 0,5 s.
Cold	IEC 68-2-1, test Aa; 96 h, -25 °C.
Dry heat	IEC 68-2-2, test Ba; 96 h, + 100 °C.
Damp heat, cyclic	IEC 68-2-30, test Db; 21 days, + 40 °C
Damp heat, steady state	IEC 68-2-3, test Ca, 21 days.
Change of temperature	IEC 68-2-14, test Na; 5 cycles, T _A = -25 °C, T _B = + 100 °C.

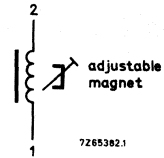

Fig. 3 Circuit diagram.

AMPLITUDE CONTROL UNITS

AMPLITUDE CONTROL UNIT

- For Monochrome Data Graphic Displays (C64 concept)

MECHANICAL DATA

Dimensions in mm

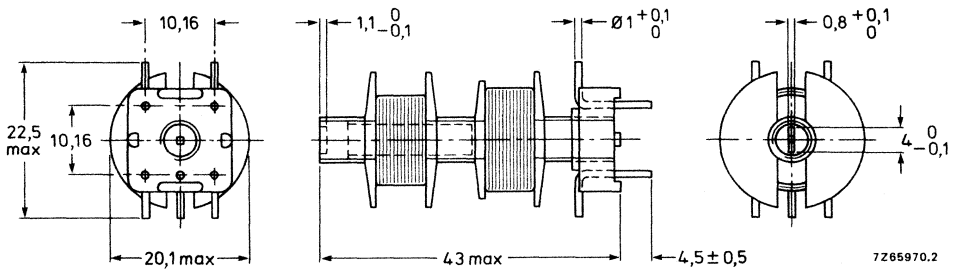

Fig. 1.

The coil has five pins for mounting on a printed-wiring board. It can be adjusted at the top by means of a trimming key.

Torque for adjustment	3 to 40 mNm
Press-through force	≥ 30 N
ΔL/L per degree of angular rotation of core	typ. $2,5 \times 10^{-4}$

Mounting

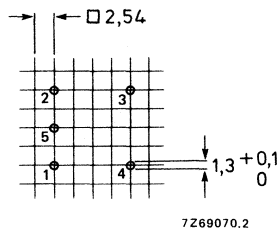

Fig. 2 Hole pattern for mounting on a printed-wiring board (solder side).

ELECTRICAL DATA

Inductance

L1-4	125 to 290 μH *
L2-3	65 to 20 μH **
L2-5	16,3 $\mu\text{H} \pm 10\%$ *

Resistance (d.c.)

R4-1	$\leq 0,58 \Omega$
R2-3	$\leq 0,215 \Omega$

Current

I1-4	$\leq 2,5 \text{ A}_{(\text{p-p})}$ at 15 kHz
	$\leq 1,3 \text{ A}_{(\text{p-p})}$ at 64 kHz
I2-5	$\leq 9 \text{ A}_{(\text{p-p})}$ at ≤ 50 kHz
	$\leq 7 \text{ A}_{(\text{p-p})}$ at 50 to 70 kHz
I2-3	$\leq 4,5 \text{ A}_{(\text{p-p})}$ at ≤ 50 kHz
	$\leq 3,5 \text{ A}_{(\text{p-p})}$ at 50 to 70 kHz

Operating voltage

V1-4 (flyback)	$\leq 120 \text{ V}_{(\text{p-p})}$
V2-5 and V2-3 (sawtooth)	$\leq 150 \text{ V}_{(\text{p-p})}$

Maximum voltage between windings 1-4 and 2-3

800 V_p

Operating frequency

15 to 64 kHz

Temperature coefficient at 20 to 100 °C

approx. $300 \times 10^{-6} / \text{K}$

Operating temperature range

-25 to +100 °C

Inflammability

according to UL94 V-1

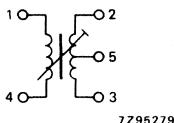

Fig. 3 Electrical diagram.

ReliabilityMaximum cumulative percentage catastrophic failures, at maximum current, $T_{\text{amb}} = 55 + 5^{\circ}\text{C}$:

after 300 h	$\leq 0,01\%$
after 1000 h	$\leq 0,013\%$
after 10 000 h	$\leq 0,02\%$
after 30 000 h	$\leq 1\%$

* At 250 mV, 1 kHz; minimum value, measured with core in position L2-3 max.

** At 250 mV, 1 kHz; minimum value, measured with core in position L1-4 max.

The coil withstands the following tests:

test	IEC 68 test method	procedure
Bump	Eb	1000 bumps, acceleration 245 m/s^2 , 6 directions
Vibration	Fc	10-55-10 Hz, ampl. 0,35 mm, 3 directions, 30 min/directions
Shock	Ea	half sine pulse shape, duration 11 ms, acceleration 490 m/s^2 , 6 directions, 3 shocks per direction
Resistance to soldering heat	Tb	method 1A
Solderability	Ta	$230 \pm 10 \text{ }^\circ\text{C}$, $2 \pm 0,5 \text{ s}$
Robustness of terminations	U_a and U_b	
Cold	Ab	$-25 \text{ }^\circ\text{C}$, 96 h
Dry heat	Bb	$+100 \text{ }^\circ\text{C}$, 96 h
Damp heat, steady state	Ca	21 days, $+40 \text{ }^\circ\text{C}$, 93% R.H.
Damp heat, cyclic	Db	21 days, $+40 \text{ }^\circ\text{C}$
Change of temperature	Na	$-25 \text{ }^\circ\text{C}$, $+100 \text{ }^\circ\text{C}$; 5 cycles

AMPLITUDE CONTROL UNIT

- For Monochrome Data Graphic Displays

MECHANICAL DATA

Dimensions in mm

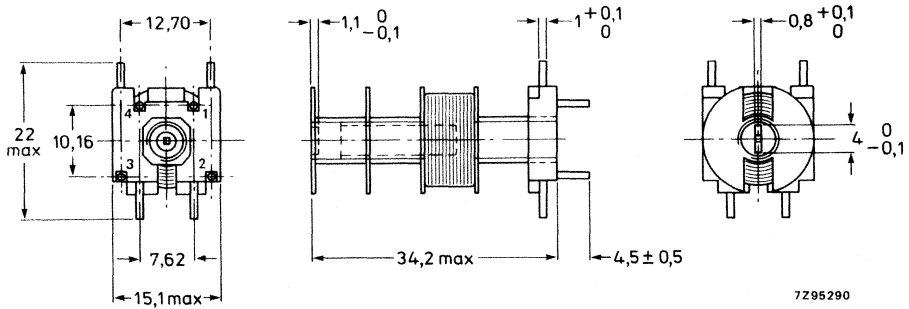
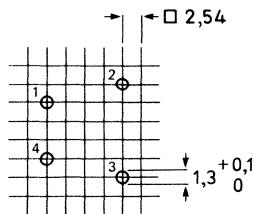

Fig. 1.

The coil has four pins for mounting on a printed-wiring board. It can be adjusted at the top by means of a trimming key.

Torque for adjustment	3 to 40 mNm
Press-through force	≥ 30 N
ΔL/L per degree of angular rotation of core	typ. $2,5 \times 10^{-4}$

Mounting



7295291.1

Fig. 2 Hole pattern for mounting on a printed-wiring board (solder side)

ELECTRICAL DATA

Inductance	36 to 50 μH^* , typ. 43 μH^*
Resistance (d.c.)	< 0,135 Ω
Current	$\leq 3,5$ A(p-p) (sawtooth)
Maximum voltage	30 V(p-p) (flyback)
Operating frequency	16 to 25 kHz
Temperature coefficient at 20 to 100 $^{\circ}\text{C}$	approx. $300 \times 10^{-6}/\text{K}$
Operating temperature range	-25 to + 100 $^{\circ}\text{C}$
Inflammability	according to UL94 V-1

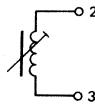

7Z95292

Fig. 4 Electrical diagram.

Reliability

Maximum cumulative percentage catastrophic failures, at maximum current, $T_{\text{amb}} = 55 + 5$ $^{\circ}\text{C}$:

after 300 h	$\leq 0,01\%$
after 1000 h	$\leq 0,013\%$
after 10 000 h	$\leq 0,02\%$
after 30 000 h	$\leq 1\%$

* At 250 mV, 1 kHz.

The amplitude control withstands the following tests:

test	IEC 68 test method	procedure
Bump	Eb	1000 bumps, acceleration 245 m/s ² , 6 directions
Vibration	Fc	10-55-10 Hz, ampl. 0,35 mm, 3 directions, 30 min/directions
Shock	Ea	half sine pulse shape, duration 11 ms, acceleration 490 m/s ² , 6 directions, 3 shocks per direction
Resistance to soldering heat	Tb	method 1A
Solderability	Ta	230 ± 10 °C, 2 ± 0,5 s
Robustness of terminations	U _a and U _b	
Cold	Ab	-25 °C, 96 h
Dry heat	Bb	+ 100 °C, 96 h
Damp heat, steady state	Ca	21 days, + 40 °C, 93% R.H.
Damp heat, cyclic	Db	21 days, + 40 °C
Change of temperature	Na	-25 °C, 100 °C, 5 cycles

LUMINANCE DELAY LINES

LUMINANCE DELAY LINE

QUICK REFERENCE DATA

Delay	270 ns
Dimensions	30 x 19 x 14 mm
Self-extinguishing	

APPLICATION

The DL270 is for use in the luminance circuit of colour television receivers.

DESCRIPTION

The delay line consists of two parallel connected coils which are astatically wound to decrease the influence of magnetic fields from other parts of the receiver. The delay line is in a plastic housing. Three pins enable the unit to be soldered directly onto a printed-wiring board.

MECHANICAL DATA

Outlines

Dimensions in mm

 $e = 2,54$ mm

Fig. 1.

Mass 6,5 g**Mounting**The unit can be soldered onto a printed-wiring board pierced with three $1,0 \pm 0,1$ mm diameter holes.**Packaging** 108 delay lines per box.

ELECTRICAL DATA (Measured at 25 °C)

Delay	270 ns ± 10%
Characteristic impedance	0,9 kΩ ± 10%
Group delay (with respect to 0,5 MHz)	
at 3,5 MHz	max. 30 ns
at 5,0 MHz	max. 60 ns
Bandwidth at -3 dB	5 MHz
Ripple with 2τ-pulse on pin 2	max. 2,5%
Breakdown voltage between pins 2 and 3	min. 50 V (d.c.)
Permissible temperature range	-25 to +70 °C

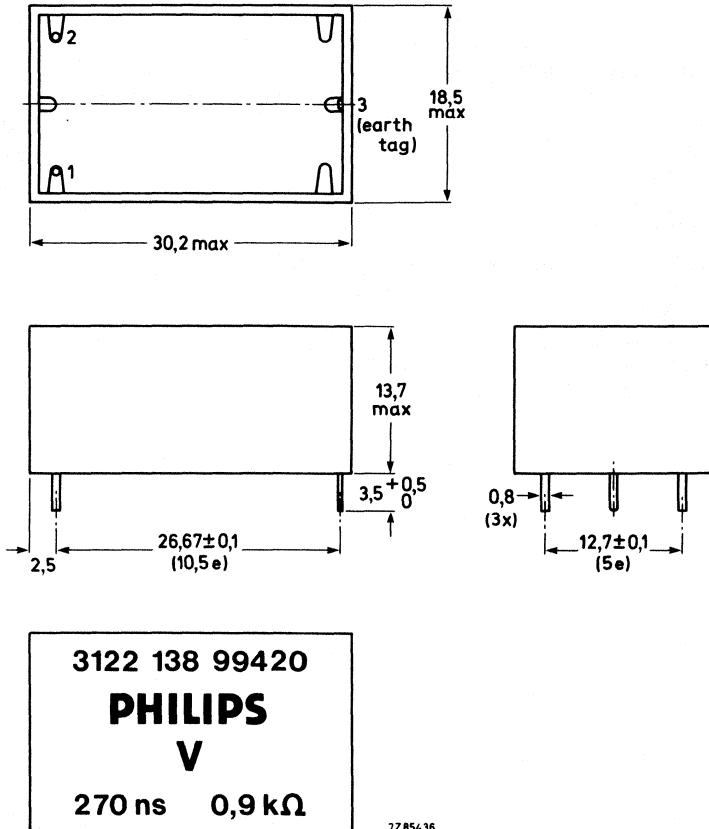
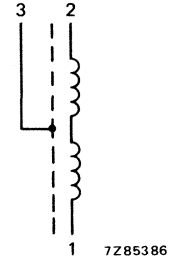

Fig. 2.

The luminance delay line withstands the following tests:

test	according to IEC 68-2 par.		procedure
Climatic			
cold	1	Ab	-25 °C, 96 h
dry heat	2	Bb	+70 °C, 96 h
damp heat cyclic	30	Db	+40 °C, 21 cycles
damp heat steady state	3	Ca	+40 °C, 21 days
change of temperature	14	Na	-25 °C/+70 °C, 5 cycles
Mechanical			
vibration sinusoidal	6	Fc	10-55-10 Hz, amplitude 0,35 mm 3 perpendicular directions, 0,5 h each
bump	29	Eb	1000 bumps in 6 directions peak acceleration 245 m/s ²
shock	27	Ea	half-sinewave, 11 ms peak acceleration 490 m/s ² 3 shocks per direction, 6 directions
resistance to soldering heat	20	Tb	method 1A
solderability	20	Ta	first part of method 1 230 ± 10 °C, 2 ± 0,5 s
robustness of terminations	21	Ua Ub	tensile 10 N, thrust 2 N 2 bends, 5 N

LUMINANCE DELAY LINE

QUICK REFERENCE DATA

Delay	330 ns
Dimensions	30 x 19 x 14 mm
Self-extinguishing properties	

APPLICATION

The DL330 is for use in the luminance circuit of colour television receivers.

DESCRIPTION

The delay line consists of two parallel connected coils which are astatically wound to decrease the influence of magnetic fields from other parts of the receiver. The delay line is enclosed in a plastic housing. Three pins enable the unit to be soldered directly onto a printed-wiring board.

MECHANICAL DATA

Dimensions in mm

Outlines

$e = 2,54$ mm

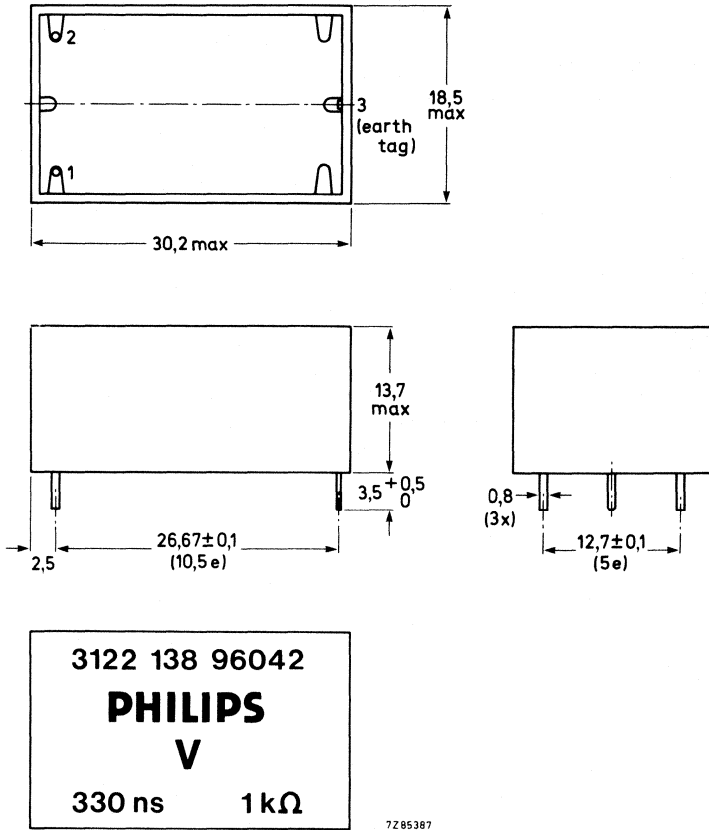

Fig. 1.

Mass 6,5 g

Mounting

The unit can be soldered directly onto a printed-wiring board pierced with three $1,0 + 0,1$ mm diameter holes.

Packaging 108 delay lines per box.

ELECTRICAL DATA

Measured at 25 °C

Delay	330 ns ± 10%
Characteristic impedance	1 kΩ ± 10%
Group delay (with respect to 0,5 MHz)	
at 3,5 MHz	max. 30 ns
at 5,0 MHz	max. 60 ns
Bandwidth at -3 dB	5 MHz
Ripple with 2τ-pulse on pin 2	max. 2,5%
Breakdown voltage between pins 2 and 3	min. 50 V (d.c.)
Permissible temperature range	-25 to +70 °C

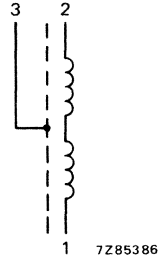

Fig. 2.

The luminance delay line withstands the following tests:

test	according to IEC 68-2 par.		procedure
Climatic			
cold	1	Ab	-25 °C, 96 h
dry heat	2	Bb	+70 °C, 96 h
damp heat cyclic	30	Db	+40 °C, 21 cycles
damp heat steady state	3	Ca	+40 °C, 21 days
change of temperature	14	Na	-25 °C/+70 °C, 5 cycles
Mechanical			
vibration sinusoidal	6	Fc	10-55-10 Hz, amplitude 0,35 mm 3 perpendicular directions, 0,5 h each
bump	29	Eb	1000 bumps in 6 directions peak acceleration 245 m/s ²
shock	27	Ea	half-sinewave, 11 ms peak acceleration 490 m/s ² 3 shocks per direction, 6 directions
resistance to soldering heat	20	Tb	method 1A
solderability	20	Ta	first part of method 1 230 ± 10 °C, 2 ± 0,5 s
robustness of terminations	21	Ua Ub	tensile 10 N, thrust 2 N 2 bends, 5 N

LUMINANCE DELAY LINE

QUICK REFERENCE DATA

Delay	390 ns
Dimensions	30 x 19 x 14 mm
Self-extinguishing properties	

APPLICATION

The DL390 is for use in the luminance circuit of colour television receivers.

DESCRIPTION

The delay line consists of two parallel connected coils which are astatically wound to decrease the influence of magnetic fields from other parts of the receiver. The delay line is enclosed in a plastic housing. Three pins enable the unit to be soldered directly onto a printed-wiring board.

MECHANICAL DATA

Dimensions in mm

Outlines

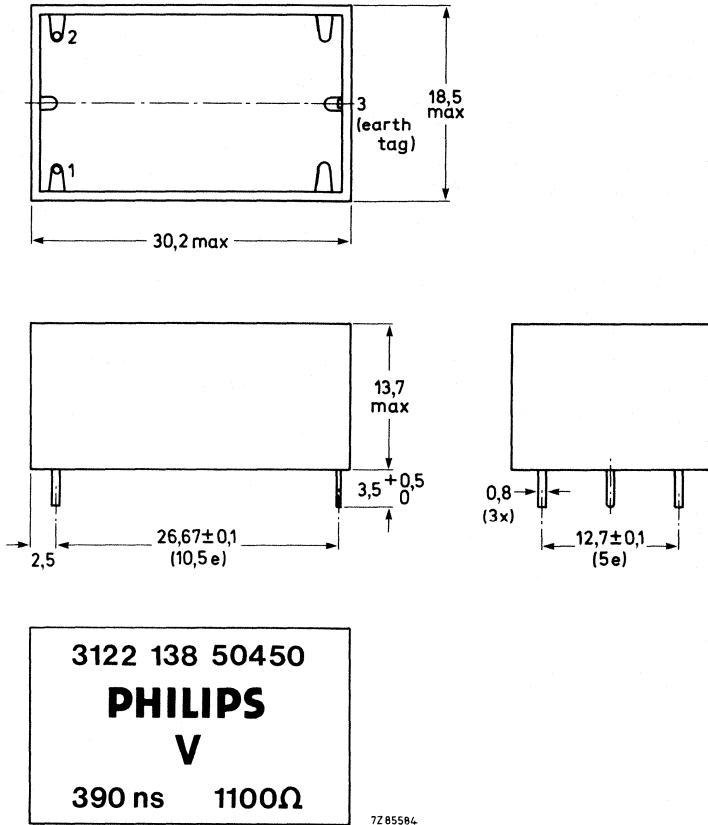

Fig. 1.

Mass 6,5 g

Mounting

The unit can be soldered directly onto a printed-wiring board pierced with three 1,0 + 0,1 mm diameter holes.

Packaging 108 delay lines per box.

ELECTRICAL DATA

Measured at 25 °C

Delay	390 ns ± 10%
Characteristic impedance	1,1 kΩ ± 10%
Group delay (with respect to 0,5 MHz)	
at 3,5 MHz	max. 45 ns
at 5,0 MHz	max. 60 ns
Bandwidth at -3 dB	5 MHz
Ripple with 2τ-pulse on pin 2	max. 3%
Breakdown voltage between pins 2 and 3	min. 50 V (d.c.)
Permissible temperature range	-25 to + 70 °C

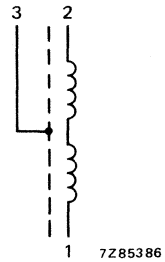

Fig. 2.

The luminance delay line withstands the following tests:

test	according to IEC 68-2 par.		procedure
Climatic			
cold	1	Ab	-25 °C, 96 h
dry heat	2	Bb	+ 70 °C, 96 h
damp heat cyclic	30	Db	+ 40 °C, 21 cycles
damp heat steady state	3	Ca	+ 40 °C, 21 days
change of temperature	14	Na	-25 °C/+ 70 °C, 5 cycles
Mechanical			
vibration sinusoidal	6	Fc	10-55-10 Hz, amplitude 0,35 mm 3 perpendicular directions, 0,5 h each
bump	29	Eb	1000 bumps in 6 directions peak acceleration 245 m/s ²
shock	27	Ea	half-sinewave, 11 ms peak acceleration 490 m/s ² 3 shocks per direction, 6 directions
resistance to soldering heat	20	Tb	method 1A
solderability	20	Ta	first part of method 1 230 ± 10 °C, 2 ± 0,5 s
robustness of terminations	21	Ua Ub	tensile 10 N, thrust 2 N 2 bends, 5 N

LUMINANCE DELAY LINE

QUICK REFERENCE DATA

Delay	470 ns
Dimensions	30 x 19 x 14 mm
Self-extinguishing	

APPLICATION

The DL470 is for use in the luminance circuit or transposer circuit of colour television receivers.

DESCRIPTION

The delay line consists of two parallel connected coils which are astatically wound to decrease the influence of magnetic fields from other parts of the receiver. The delay line is in a plastic housing. Three pins enable the unit to be soldered directly onto a printed-wiring board.

DL470

MECHANICAL DATA

Outlines

Dimensions in mm

$e = 2,54$ mm

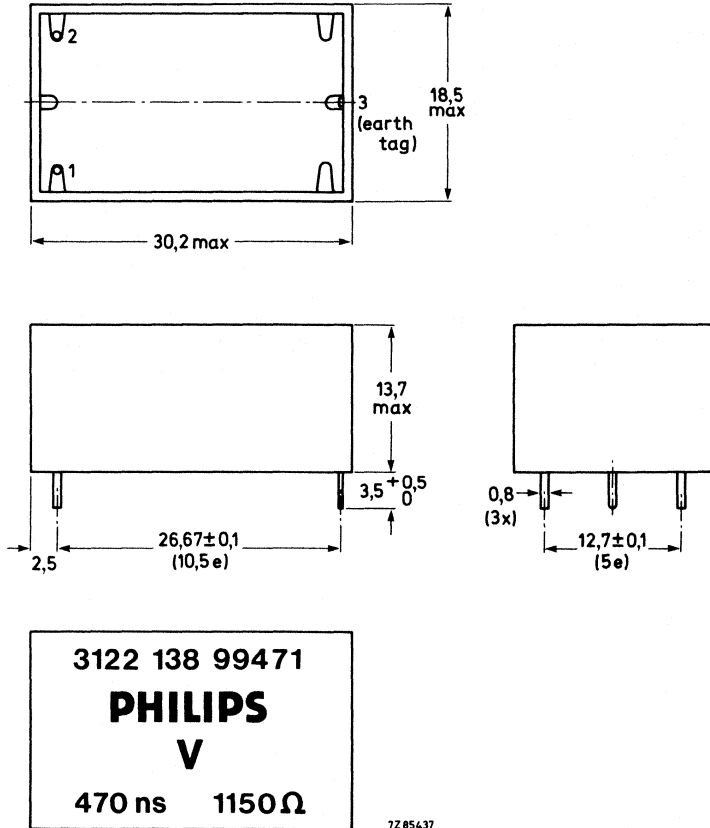

Fig. 1.

Mass 6,5 g

Mounting

The unit can be soldered onto a printed-wiring board pierced with three 1,0 + 0,1 mm diameter holes.

Packaging 108 delay lines per box.

ELECTRICAL DATA (Measured at 25 °C)

Delay	470 ns ± 10%
Characteristic impedance	1150 Ω ± 10%
Group delay (with respect to 1,0 MHz)	
at 3,5 MHz	max. 45 ns
at 5,0 MHz	max. 60 ns
Bandwidth at -3 dB	5 MHz
Ripple with 2τ-pulse on pin 2	max. 3%
Breakdown voltage between pins 2 and 3	min. 50 V (d.c.)
Permissible temperature range	-25 to + 70 °C

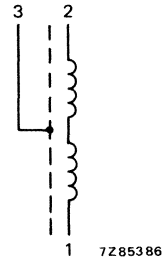

Fig. 2.

The luminance delay line withstands the following tests:

test	according to IEC 68-2 par.		procedure
Climatic			
cold	1	Ab	-25 °C, 96 h
dry heat	2	Bb	+ 70 °C, 96 h
damp heat cyclic	30	Db	+ 40 °C, 21 cycles
damp heat steady state	3	Ca	+ 40 °C, 21 days
change of temperature	14	Na	-25 °C/+ 70 °C, 5 cycles
Mechanical			
vibration sinusoidal	6	Fc	10-55-10 Hz, amplitude 0,35 mm 3 perpendicular directions, 0,5 h each
bump	29	Eb	1000 bumps in 6 directions peak acceleration 245 m/s ²
shock	27	Ea	half-sinewave, 11 ms peak acceleration 490 m/s ² 3 shocks per direction, 6 directions
resistance to soldering heat	20	Tb	method 1A
solderability	20	Ta	first part of method 1 230 ± 10 °C, 2 ± 0,5 s
robustness of terminations	21	Ua Ub	tensile 10 N, thrust 2 N 2 bends, 5 N

GLASS DELAY LINES AND COMB FILTERS

**This chapter includes our standard range of glass delay lines and comb filters.
Other specifications can be achieved at customer's request.**

DELAY LINE

QUICK REFERENCE DATA

For receivers up to Brazilian PAL-M standard

Nominal frequency	3,575611 MHz
Phase delay time	63,486 μ s
Dimensions	37 x 7,5 x 28,5 mm
Self-extinguishing properties	

APPLICATION

The DL63 is intended for use in decoder circuits of colour television receivers.

DESCRIPTION

A very thin slab of zero TC glass provided with two transducers is shock-proof mounted in a housing with self-extinguishing properties. Four pins enable the unit to be soldered directly onto a printed-wiring board.

MECHANICAL DATA

Dimensions in mm

Outlines

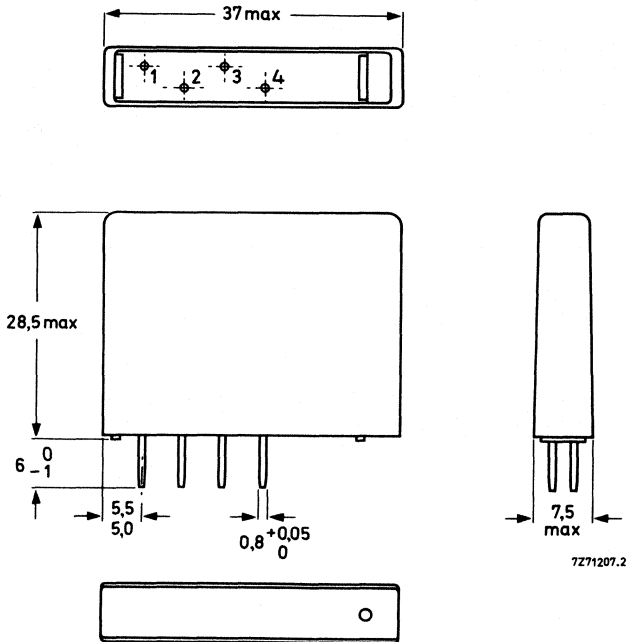

Fig. 1.

Mass 7 g

Mounting

The unit can be soldered directly onto a printed-wiring board.

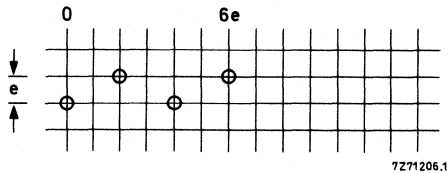

Fig. 2 Recommended hole pattern for mounting on a printed-wiring board: $e = 2,54$ mm. The tolerance on the distances of the different holes to the 0-line is $\pm 0,1$ mm. Hole diameter is $1,0 + 0,1$ mm.

ELECTRICAL DATA

Measured with the circuit of Fig. 3 at 25 °C and f_0 (unless otherwise specified)

Nominal frequency (f_0)	3,575611 MHz
Phase delay time (τ)	$63,486 \pm 0,005 \mu s$
Bandwidth at -3 dB	from $\leq 2,8$ to $\geq 4,5$ MHz
Insertion loss	9 ± 3 dB
Drift of phase delay from + 10 to + 60 °C (relative to + 25 °C)	typ. 5 ns
Maximum input voltage (p-p)	10 V
Spurious signals	
3 τ signals	≤ -22 dB with respect to 1 τ signal
other signals	≤ -30 dB with respect to 1 τ signal
Phase relation $\varphi_{4.3} - \varphi_{2.1}$	0°
Storage temperature range	-40 to $+70$ °C

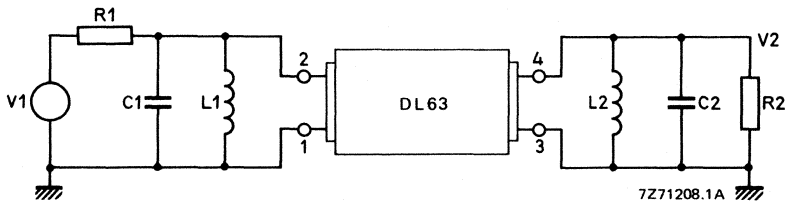

Fig. 3.

Terminations

$R1 = R2 = 560 \Omega$

$C1 = 20$ pF } total capacitance of test jig without delay line i.e. wiring capacitance,
 $C2 = 30$ pF } capacitance of coil and extra trimming capacitor.

$L1 = 15,2 \mu H$

$L2 = 14,1 \mu H$

Application circuit

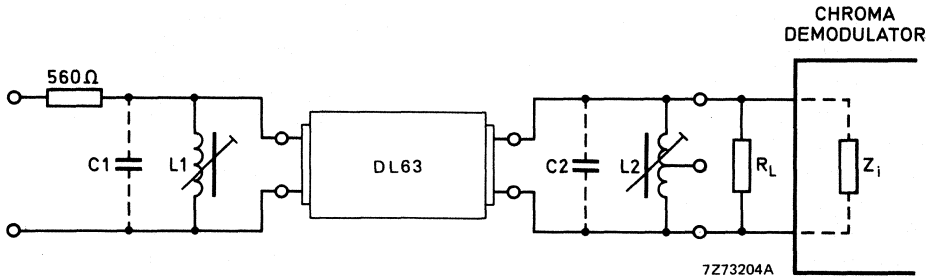

Fig. 4.

$$(R_L // Z_i) = 560 \Omega$$

C1, C2 < 30 pF (wiring capacitance and capacitance of the coil)

L1, L2 nominal values depend on values of C1 and C2 to produce the reactances:

$$X1 = \frac{\omega_0 L1}{1 - \omega_0^2 L1 C1} = 405 \Omega$$

$$X2 = \frac{\omega_0 L2}{1 - \omega_0^2 L2 C2} = 405 \Omega$$

$$f_0 = 3,575611 \text{ MHz.}$$

Maximum bandwidth is obtained at minimum C1 and C2.

Recommended adjustment range of the coils -19 to +36%.

DELAY LINE

QUICK REFERENCE DATA

Nominal frequency	7,5 MHz
Phase delay time	64,4 μ s
Dimensions	37 x 7,5 x 28,5 mm
Self-extinguishing properties	

APPLICATION

The DL680 is for use in video long play equipment.

DESCRIPTION

A very thin slab of zero TC glass provided with two transducers is shock-proof mounted in a housing with self-extinguishing properties. Four pins enable the unit to be soldered directly onto a printed-wiring board.

MECHANICAL DATA

Outlines

Dimensions in mm

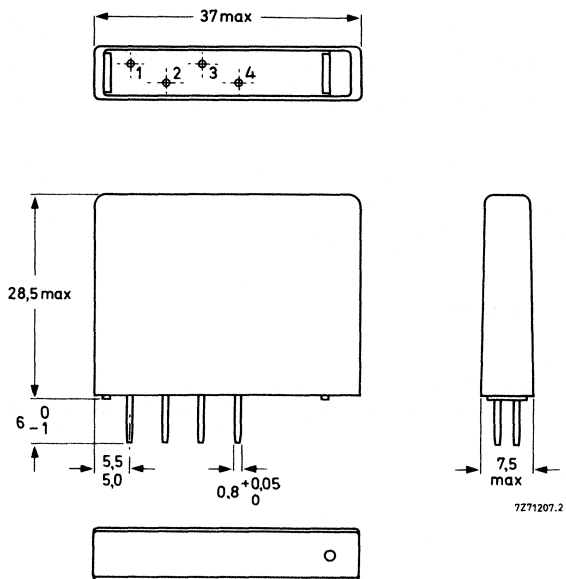

Fig. 1.

Mass 7 g

Mounting

The unit can be soldered directly onto a printed-wiring board.

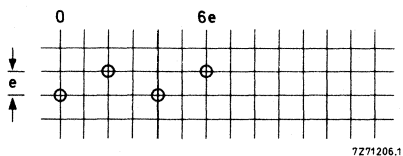

Fig. 2 Recommended hole pattern for mounting on a printed-wiring board:
 $e = 2,54$ mm. The tolerance on the distances of the different holes to the 0-line
 is $\pm 0,1$ mm. Hole diameter is $1,0 + 0,1$ mm.

ELECTRICAL DATA

Measured with the circuit of Fig. 3 at 25 °C and f_0 (unless otherwise specified)

Nominal frequency (f_0)	7,5 MHz
Phase delay time (τ)	$64,4 \pm 0,05 \mu\text{s}$
Bandwidth at -3 dB	from $\leq 5,5$ to $\geq 8,5$ MHz
Insertion loss	≤ 17 dB
Drift of phase delay from +10 to +60 °C (relative to +25 °C)	≤ 10 ns
Maximum input voltage (p-p)	5 V
Spurious signals	
3 τ signals	≤ -20 dB with respect to 1 τ signal
other signals	≤ -30 dB with respect to 1 τ signal
Storage temperature range	-40 to $+70$ °C

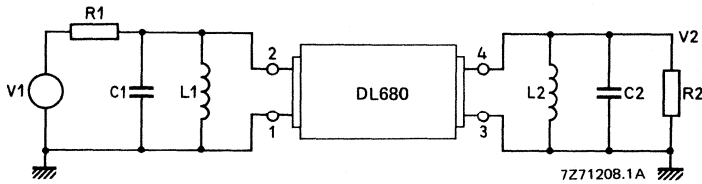

Fig. 3.

Terminations

$R1 = R2 = 150 \Omega$

$C1 = 20 \text{ pF}$ } total capacitance of test jig without delay-line i.e. wiring capacitance, capacitance of coil
 $C2 = 20 \text{ pF}$ } and extra trimming capacitor.

$L1 = 2,0 \mu\text{H}$

$L2 = 2,0 \mu\text{H}$

DELAY LINE

QUICK REFERENCE DATA

For receivers up to European PAL standard

Nominal frequency	4,433619 MHz
Phase delay time	63,943 μ s
Dimensions	37 x 7,5 x 28,5 mm
Self-extinguishing properties	

APPLICATION

The DL701 is intended for use in decoder circuits of colour television receivers, or in drop-out circuits of video cassette recorders.

DESCRIPTION

A very thin slab of zero TC glass provided with two transducers is shock-proof mounted in a housing with self-extinguishing properties. Four pins enable the unit to be soldered directly onto a printed-wiring board.

MECHANICAL DATA

Outlines

Dimensions in mm

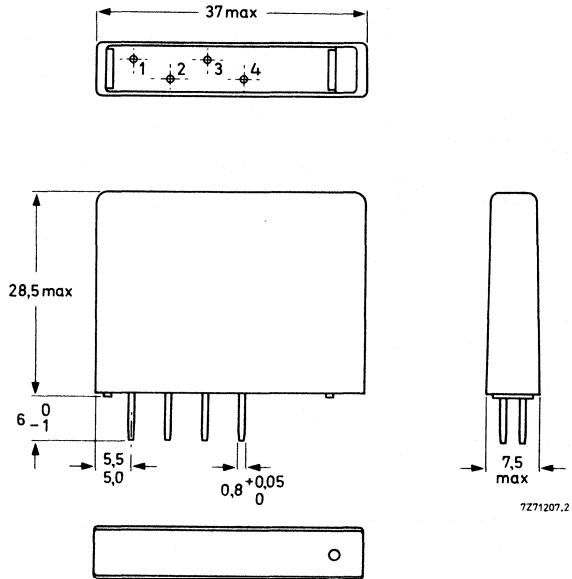

Fig. 1.

Mass 7 g

Mounting

The unit can be soldered directly onto a printed-wiring board.

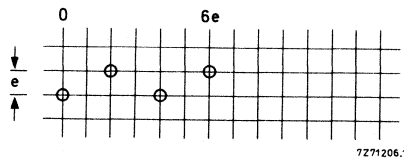

Fig. 2 Recommended hole pattern for mounting on a printed-wiring board: $e = 2,54$ mm. The tolerance on the distances of the different holes to the 0-line is $\pm 0,1$ mm. Hole diameter is $1,0 + 0,1$ mm.

ELECTRICAL DATA

Measured with the circuit of Fig. 3 at 25 °C and f_0 (unless otherwise specified)

Nominal frequency (f_0)	4,433619 MHz
Phase delay time (τ)	63,943 ± 0,005 μ s
Bandwidth at -3 dB	from $\leq 3,43$ to $\geq 5,23$ MHz
Insertion loss	9 ± 3 dB
Drift of phase delay from +10 to +60 °C (relative to +25 °C)	max. 5 ns, typ. 3 ns
Maximum input voltage (p-p)	10 V
Spurious signals	
3 τ signals	≤ -28 dB with respect to 1 τ signal ←
other signals	≤ -33 dB with respect to 1 τ signal
Phase relation $\varphi_{4-3} - \varphi_{2-1}$	180°
Storage temperature range	-40 to +70 °C

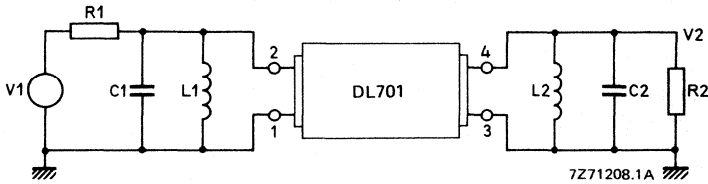

Fig. 3.

Terminations

R1 = R2 = 390 Ω

C1 = 20 pF

C2 = 30 pF

L1 = 8,64 μ H

L2 = 8,10 μ H

} total capacitance of test jig without delay-line i.e. wiring capacitance,
} capacitance of coil and extra trimming capacitor.

Application circuit

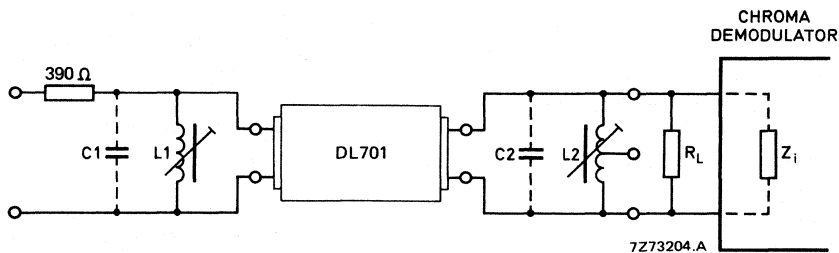

Fig. 4.

$$(R_L // Z_i) = 390 \Omega$$

$C1, C2 < 30 \text{ pF}$ (wiring capacitance and capacitance of the coil)

$L1, L2$ nominal values depend on values of $C1$ and $C2$ to produce the reactances:

$$X1 = \frac{\omega_0 L1}{1 - \omega_0^2 L1 C1} = 278 \Omega$$

$$X2 = \frac{\omega_0 L2}{1 - \omega_0^2 L2 C2} = 278 \Omega$$

$$f_0 = 4,433619 \text{ MHz}$$

Maximum bandwidth is obtained at minimum $C1$ and $C2$.

Recommended adjustment range of the coils -19 to $+36\%$.

DELAY LINE

QUICK REFERENCE DATA

For video recorders to European PAL standard

Nominal frequency	4,433619 MHz
Phase delay time	63,935 μ s
Dimensions	37 x 7,5 x 28,5 mm
Self-extinguishing properties	

APPLICATION

The DL703 is intended for use in dropout circuits of PAL video recorders. It has been designed to have a wider bandwidth at both the -3 dB and -10 dB points.

DESCRIPTION

A very thin slab of zero TC glass provided with two transducers is shock-proof mounted in a housing with self-extinguishing properties. Four pins enable the unit to be soldered directly onto a printed-wiring board.

MECHANICAL DATA

Outlines

Dimensions in mm

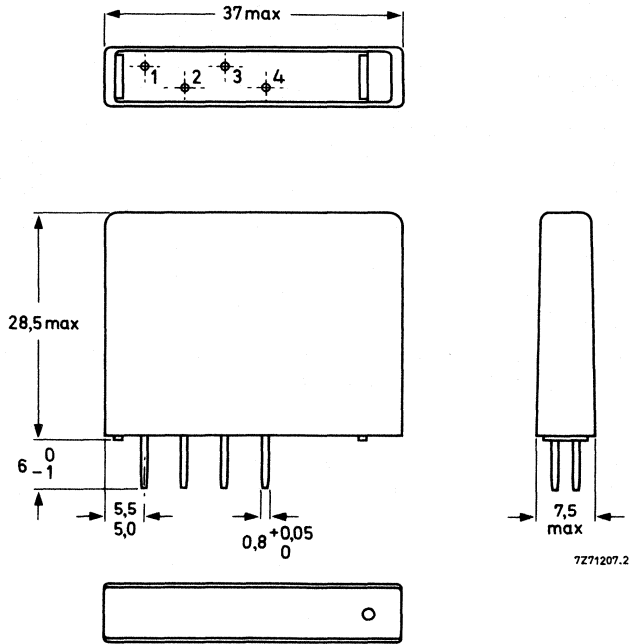
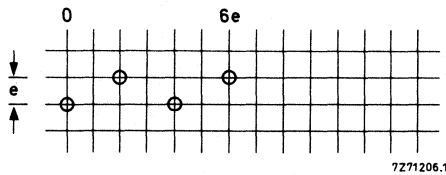

Fig. 1.

Mass 7 g

Mounting

The unit can be soldered directly onto a printed-wiring board.

Fig. 2 Recommended hole pattern for mounting on a printed-wiring board: $e = 2,54$ mm. The tolerance on the distances of the different holes to the 0-line is $\pm 0,1$ mm. Hole diameter is $1,0 + 0,1$ mm.

ELECTRICAL DATA

Measured with the circuit of Fig. 3 at 25 °C and f_0 (unless otherwise specified)

Nominal frequency (f_0)	4,433619 MHz
Phase delay time (τ)	63,935 ± 0,005 μ s
Bandwidth at -3 dB	from ≤ 3,03 to ≥ 5,43 MHz
Bandwidth at -10 dB	from ≤ 2,63 to ≥ 6,23 MHz
Insertion loss	9 ± 3 dB
Drift of phase delay from + 10 to + 60 °C (relative to + 25 °C)	max. 5 ns, typ. 3 ns
Maximum input voltage (p-p)	15 V
Spurious signals	
3 τ signals	≤ -28 dB with respect to 1 τ signal
other signals	≤ -26 dB with respect to 1 τ signal
Phase relation $\varphi_{4-3} - \varphi_{2-1}$	180°
Storage temperature range	-40 to + 70 °C

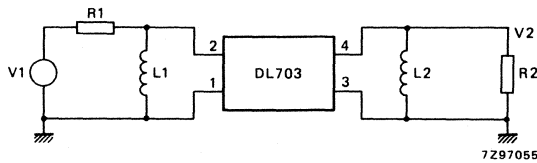

Fig. 3.

Terminations

$R1 = R2 = 390 \Omega$

$L1 = L2 = 18,0 \mu H$

DELAY LINE

QUICK REFERENCE DATA

For receivers up to European PAL and SECAM standard

Nominal frequency	4,433619 MHz
Phase delay time	63,943 μ s
Dimensions	37 x 7,5 x 28,5 mm
Self-extinguishing properties	

APPLICATION

The DL711 is intended for use in decoder circuits of colour television receivers.

DESCRIPTION

A very thin slab of zero TC glass provided with two transducers is shock-proof mounted in a housing with self-extinguishing properties. Four pins enable the unit to be soldered directly onto a printed-wiring board.

MECHANICAL DATA
Outlines

Dimensions in mm

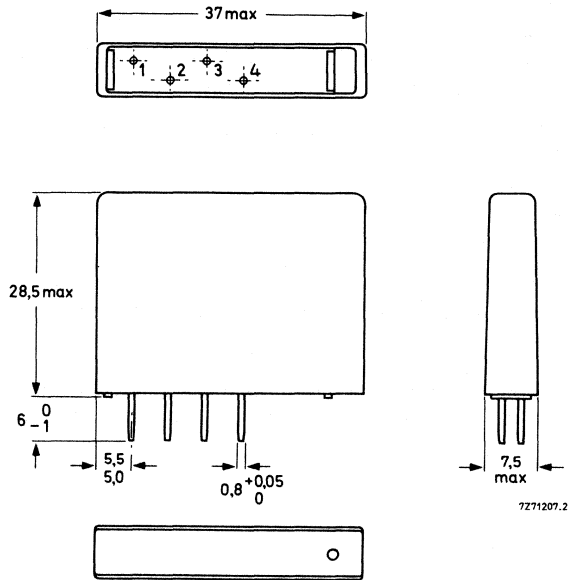
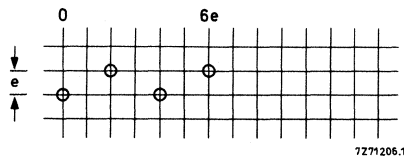

Fig. 1.

Mass 7 g**Mounting**

The unit can be soldered directly onto a printed-wiring board.

Fig. 2 Recommended hole pattern for mounting on a printed-wiring board: $e = 2,54$ mm. The tolerance on the distances of the different holes to the 0-line is $\pm 0,1$ mm. Hole diameter is $1,0 + 0,1$ mm.

ELECTRICAL DATA

Measured with the circuit of Fig. 3 at 25 °C and f_0 (unless otherwise specified)

Nominal frequency (f_0)	4,433619 MHz
Phase delay time (τ)	$63,943 \pm 0,005 \mu s$
Bandwidth at -3 dB	from $\leq 3,43$ to $\geq 5,23$ MHz
Insertion loss	9 ± 3 dB
Drift of phase delay from +10 to +60 °C (relative to +25 °C)	max. 5 ns, typ. 3 ns
Maximum input voltage (p-p)	10 V
Spurious signals*	
3 τ signals	≤ -33 dB with respect to 1 τ signal
other signals	≤ -33 dB with respect to 1 τ signal
Phase relation $\varphi_{4-3} - \varphi_{2-1}$	180°
Storage temperature range	-40 to +70 °C

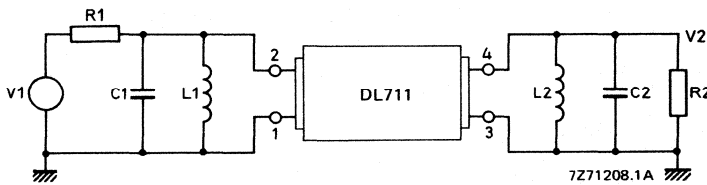

Fig. 3.

Terminations

$R1 = R2 = 390 \Omega$

$C1 = 20$ pF

$C2 = 30$ pF

$L1 = 8,64 \mu H$

$L2 = 8,10 \mu H$

} total capacitance of test jig without delay-line i.e. wiring capacitance,
} capacitance of coil and extra trimming capacitor.

* Measured in frequency range 3,9 to 4,75 MHz.

Application circuit

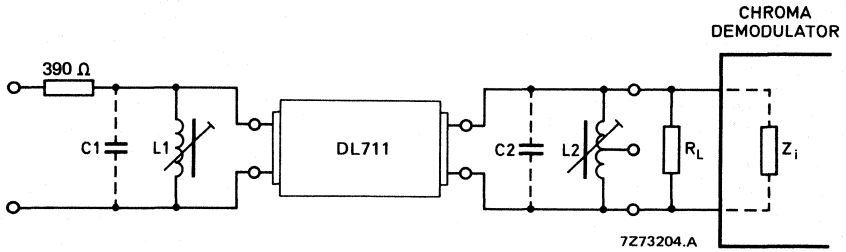

Fig. 4.

$$(R_L // Z_i) = 390 \Omega$$

$C_1, C_2 < 30 \text{ pF}$ (wiring capacitance and capacitance of the coil)

L_1, L_2 nominal values depend on values of C_1 and C_2 to produce the reactances:

$$X_1 = \frac{\omega_0 L_1}{1 - \omega_0^2 L_1 C_1} = 278 \Omega$$

$$X_2 = \frac{\omega_0 L_2}{1 - \omega_0^2 L_2 C_2} = 278 \Omega$$

$$f_0 = 4,433619 \text{ MHz}$$

Maximum bandwidth is obtained at minimum C_1 and C_2 .

Recommended adjustment range of the coils -19 to $+36\%$.

DELAY LINES

QUICK REFERENCE DATA

For receivers up to Argentina PAL-N standard

Nominal frequency	3,582056 MHz
Phase delay time	
DL720	63,929 μ s
DL721	64,069 μ s
DL722	64,069 μ s
Dimensions	37 x 7,5 x 28,5 mm
Self-extinguishing properties	

APPLICATION

These delay lines are for use in decoder circuits of colour television receivers.

DESCRIPTION

A very thin slab of zero TC glass provided with two transducers is shock-proof mounted in a housing with self-extinguishing properties. Four pins enable the unit to be soldered directly onto a printed-wiring board.

DL720
DL721
DL722

4322 027 84721
4322 027 84731
4322 027 84741

MECHANICAL DATA
Outlines

Dimensions in mm

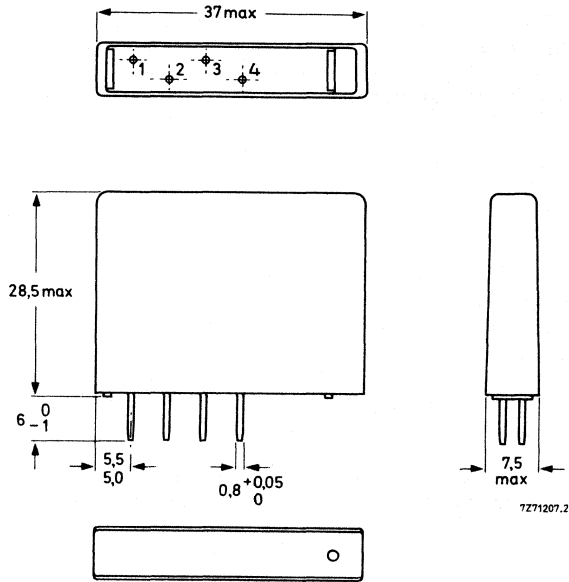

Fig. 1.

Mass 7 g

Mounting

The unit can be soldered directly onto a printed-wiring board.

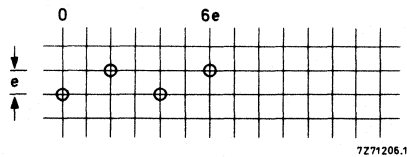

Fig. 2 Recommended hole pattern for mounting on a printed-wiring board: $e = 2,54$ mm. The tolerance on the distances of the different holes to the 0-line is $\pm 0,1$ mm. Hole diameter is $1,0 + 0,1$ mm.

ELECTRICAL DATA

Measured with the circuit of Fig. 3 at 25 °C and f_0 (unless otherwise specified)

Nominal frequency (f_0)	3,582056 MHz
Phase delay time (τ)	
DL720	63,929 ± 0,005 μ s
DL721 and DL722	64,069 ± 0,005 μ s
Bandwidth at -3 dB	from $\leq 2,8$ to $\geq 4,5$ MHz
Insertion loss	9 ± 3 dB
Drift of phase delay from + 10 to + 60 °C (relative to + 25 °C)	max. 5 ns, typ. 3 ns
Maximum input voltage (p-p)	10 V
Spurious signals	
3 τ signals	≤ -22 dB with respect to 1 τ signal
other signals	≤ -28 dB with respect to 1 τ signal
Phase relation $\varphi_{4.3} - \varphi_{2.1}$	
DL720	0°
DL721 and DL722	180°
Storage temperature range	-40 to + 70 °C

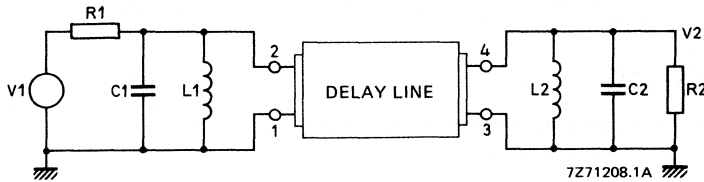

Fig. 3.

Terminations

$R1 = R2 = 560 \Omega$ for DL720 and DL721; $R1 = R2 = 390 \Omega$ for DL722.

$C1 = 20 \text{ pF}$ } total capacitance of test jig without delay-line i.e. wiring capacitance,

$C2 = 30 \text{ pF}$ } capacitance of coil and extra trimming capacitor.

$L1 = 15,2 \mu\text{H}$ for DL720; $L1 = 8,64 \mu\text{H}$ for DL722.

$L2 = 14,1 \mu\text{H}$ for DL721; $L2 = 8,10 \mu\text{H}$ for DL722.

Application circuit

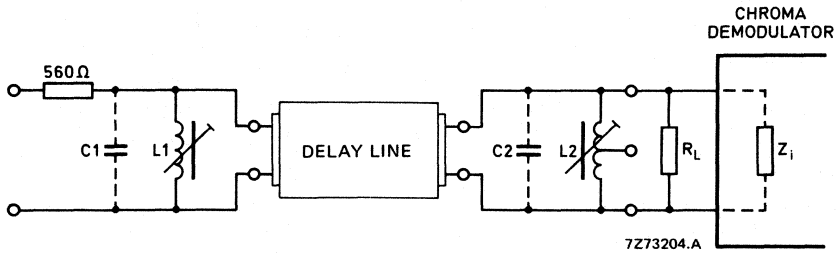

Fig. 4.

$(R_L // Z_i) = 560 \Omega$ for DL720 and DL721; $(R_L // Z_i) = 390 \Omega$ for DL722.

$C1, C2 < 30 \text{ pF}$ (wiring capacitance and capacitance of the coil)

$L1, L2$ nominal values depend on values of $C1$ and $C2$ to produce the reactances:

$$X1 = \frac{\omega_0 L1}{1 - \omega_0^2 L1 C1} = 405 \Omega \text{ for DL720 and DL721; } X1 = 278 \Omega \text{ for DL722.}$$

$$X2 = \frac{\omega_0 L2}{1 - \omega_0^2 L2 C2} = 405 \Omega \text{ for DL720 and DL721; } X2 = 278 \Omega \text{ for DL722.}$$

$$f_0 = 3,582056 \text{ MHz.}$$

Maximum bandwidth is obtained at minimum $C1$ and $C2$.

Recommended adjustment range of the coils -19 to $+36\%$.

DELAY LINE

QUICK REFERENCE DATA

Nominal frequency	3,579545 MHz
Phase delay time	63,555 μ s
Dimensions	37 x 7,5 x 28,5 mm
Self-extinguishing properties	

APPLICATION

The DL750 is intended for use as a comb filter in colour television receivers to NTSC standard.

DESCRIPTION

A very thin slab of zero TC glass provided with two transducers is shock-proof mounted in a housing with self-extinguishing properties. Four pins enable the unit to be soldered directly onto a printed-wiring board.

DL750

4322 027 84751
4322 027 84752

MECHANICAL DATA
Outlines

Dimensions in mm

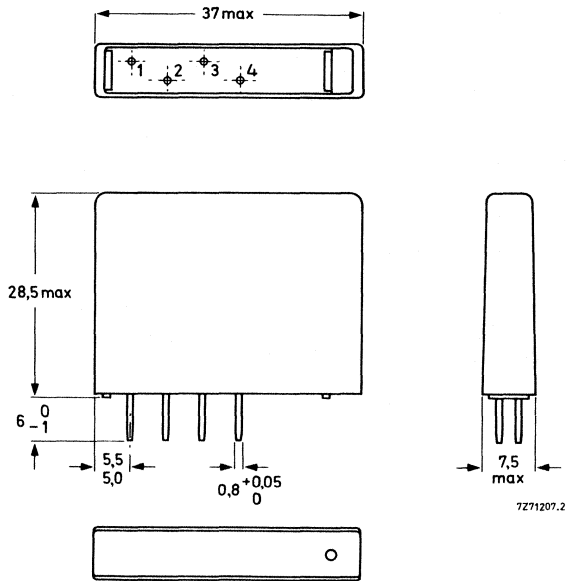

Fig. 1.

Mass 7 g

Mounting

The unit can be soldered directly onto a printed-wiring board.

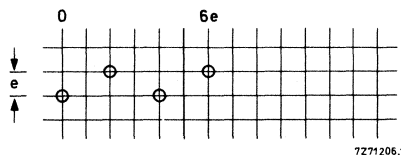

Fig. 2 Recommended hole pattern for mounting on a printed-wiring board: $e = 2,54$ mm. The tolerance on the distances of the different holes to the 0-line is $\pm 0,1$ mm. Hole diameter is $1,0 + 0,1$ mm.

ELECTRICAL DATA

Measured with the circuit of Fig. 3 at 25 °C and f_0 (unless otherwise specified)

Nominal frequency (f_0)	3,579545 MHz
Phase delay time (τ)	$63,555 \pm 0,005 \mu\text{s}$
Bandwidth at -3 dB	from $\leq 2,8$ to $\geq 4,5$ MHz
Insertion loss	9 ± 3 dB
Drift of phase delay from $+10$ to $+60$ °C (relative to $+25$ °C)	typ. 5 ns
Maximum input voltage (p-p)	10 V
Spurious signals	
3 τ signals	≤ -30 dB with respect to 1 τ signal
other signals	≤ -28 dB with respect to 1 τ signal
Phase relation $\varphi_{4.3} - \varphi_{2.1}$	180°
Storage temperature range	-40 to $+70$ °C

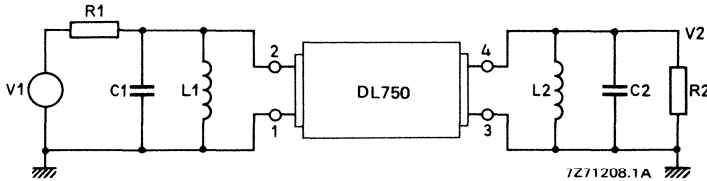

Fig. 3.

Terminations

- R1 = R2 = 560 Ω
- C1 = 20 pF | total capacitance of test jig without delay-line i.e. wiring capacitance,
- C2 = 30 pF | capacitance of coil and extra trimming capacitor.
- L1 = 15,2 μH
- L2 = 14,1 μH

Application circuit

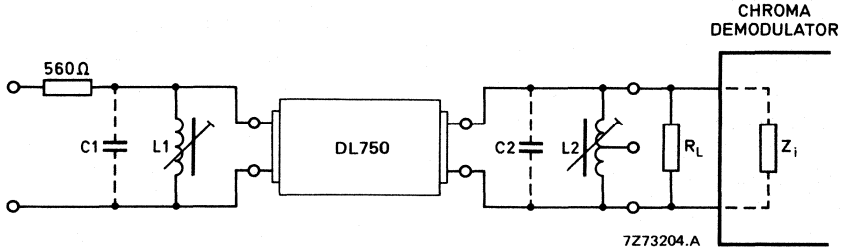

Fig. 4.

$$(R_L // Z_i) = 560 \Omega$$

$C_1, C_2 < 30 \text{ pF}$ (wiring capacitance and capacitance of the coil)

L_1, L_2 nominal values depend on values of C_1 and C_2 to produce the reactances:

$$X_1 = \frac{\omega_0 L_1}{1 - \omega_0^2 L_1 C_1} = 405 \Omega$$

$$X_2 = \frac{\omega_0 L_2}{1 - \omega_0^2 L_2 C_2} = 405 \Omega$$

$$f_0 = 3,579545 \text{ MHz.}$$

Maximum bandwidth is obtained at minimum C_1 and C_2 .

Recommended adjustment range of the coils -19 to $+36\%$.

DELAY LINE

QUICK REFERENCE DATA

For video recorders to NTSC standard

Nominal frequency	3,579545 MHz
Phase delay time	64 μ s
Dimensions	37 x 7,5 x 28,5 mm
Self-extinguishing properties	

APPLICATION

The DL752 is for use in comb filter circuits of NTSC video recorders.

DESCRIPTION

A very thin slab of zero TC glass provided with two transducers is shock-proof mounted in a housing with self-extinguishing properties. Four pins enable the unit to be soldered directly onto a printed-wiring board.

MECHANICAL DATA
Outlines

Dimensions in mm

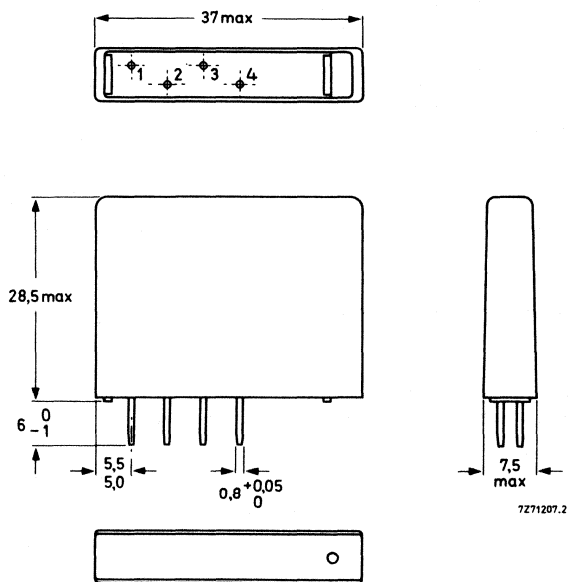

Fig. 1.

Mass 7 g

Mounting

The unit can be soldered directly onto a printed-wiring board.

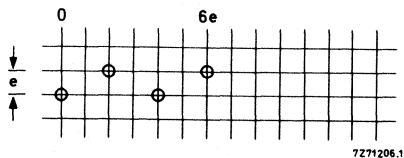

Fig. 2 Recommended hole pattern for mounting on a printed-wiring board;
 $e = 2,54$ mm. The tolerance on the distances of the different holes to the
 0-line is $\pm 0,1$ mm. Hole diameter is $1,0 + 0,1$ mm.

ELECTRICAL DATA

Measured with the circuit of Fig. 3 at $25 \pm 5 \text{ }^\circ\text{C}$, R.H. = 40 to 60%.

Nominal frequency (f_0)	3,579545 MHz
Central comb frequency (f_1)	3,57168 MHz
Lower comb frequency (f_-)	3,11538 MHz
Upper comb frequency (f_+)	4,05944 MHz
Transducer attenuation at f_0	$10 \pm 3 \text{ dB}$
Comb depth at f_1 with respect to f_0 *	$\geq 24 \text{ dB}$
Comb depth at f_- and f_+ with respect to f_0	$\geq 10 \text{ dB}$
Phase delay time (τ)	$64 \text{ } \mu\text{s}$
Bandwidth (-3 dB), measured with switch S open	$f_0 \pm 0,5 \text{ MHz}$
Maximum input voltage (p-p)	10 V
Spurious signals at the output, at f_0 **	
2 τ signals with respect to 1 τ signal	$\leq -20 \text{ dB}$
other signals with respect to 1 τ signal	$\leq -26 \text{ dB}$
3 τ signals with respect to 1 τ signal	$\leq -18 \text{ dB}$
Operating temperature range \blacktriangle	$+10 \text{ to } +60 \text{ }^\circ\text{C}$

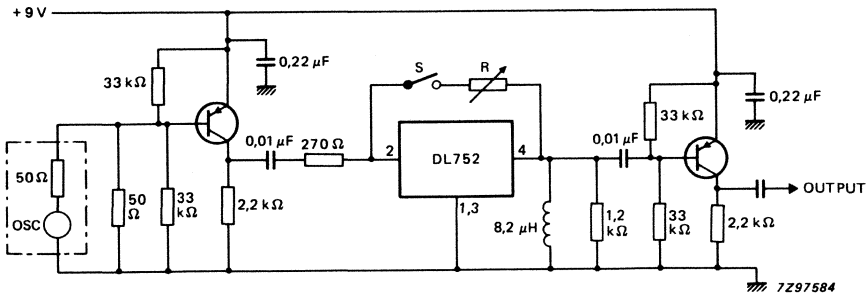

Fig. 3 Test circuit.

* Comb depth is adjusted to a maximum at f_1 by varying direct path resistor R ($0 - 1 \text{ k}\Omega$).
 ** Reflections are measured using a $5 \text{ } \mu\text{s}$ long input pulse.
 \blacktriangle Over the whole temperature range the comb depth at f_1 is $\geq 18 \text{ dB}$, and at f_+ and f_- $\geq 8 \text{ dB}$.

DELAY LINE

QUICK REFERENCE DATA

For video recorders to European PAL standard

Nominal frequency	4,433619 MHz
Phase delay time	128 μ s
Dimensions	37 x 7,5 x 28,5 mm
Self-extinguishing properties	

APPLICATION

The DL872 is for use in comb filter circuits of PAL video recorders.

DESCRIPTION

A very thin slab of zero TC glass provided with a split transducer is shock-proof mounted in a housing with self-extinguishing properties. Four pins enable the unit to be soldered directly onto a printed-wiring board.

MECHANICAL DATA

Dimensions in mm

Outlines

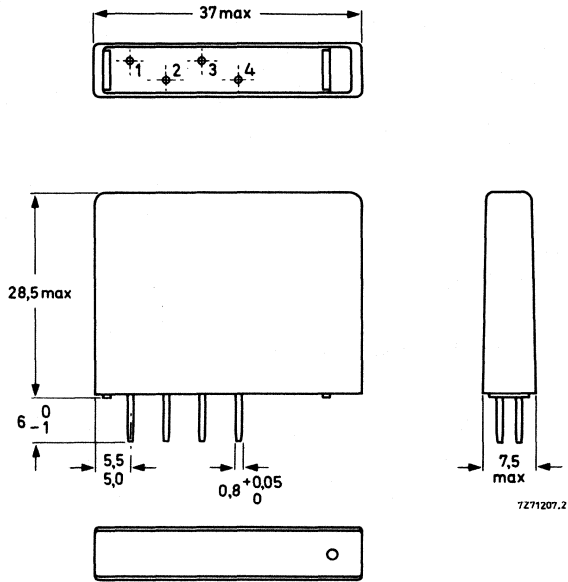

Fig. 1.

Mass 7 g

Mounting

The unit can be soldered directly onto a printed-wiring board.

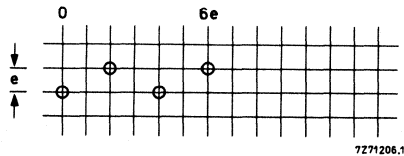

Fig. 2 Recommended hole pattern for mounting on a printed-wiring board; $e = 2,54$ mm. The tolerance on the distances of the different holes to the 0-line is $\pm 0,1$ mm. Hole diameter is $1,0 + 0,1$ mm.

ELECTRICAL DATA

Measured with the circuit of Fig. 3 at $25 \pm 5 \text{ }^\circ\text{C}$, R.H. = 40 to 60%.

Nominal frequency (f_0)	4,433619 MHz
Central comb frequency (f_1)	4,42971 MHz
Lower comb frequency (f_-)	3,92971 MHz
Upper comb frequency (f_+)	4,92971 MHz
Transducer attenuation at f_0	$18 \pm 3 \text{ dB}$
Comb depth at f_1 with respect to f_0 *	$\geq 20 \text{ dB}$
Comb depth at f_- and f_+ with respect to f_0	$\geq 10 \text{ dB}$
Phase delay time (τ)	$128 \text{ } \mu\text{s}$
Bandwidth (-3 dB), measured with switch S open	$f_0 \pm 0,5 \text{ MHz}$
Maximum input voltage (p-p)	10 V
Spurious signals at the output, at f_0 **	
2 τ signals with respect to 1 τ signal	$\leq -12 \text{ dB}$
other signals with respect to 1 τ signal	$\leq -23 \text{ dB}$
Operating temperature range▲	$+ 10 \text{ to } + 60 \text{ }^\circ\text{C}$

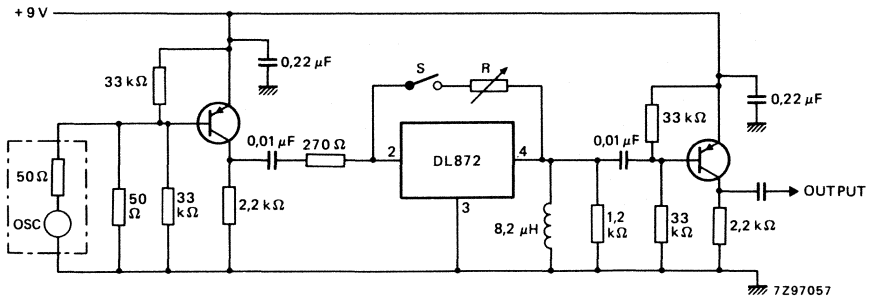

Fig. 3 Test circuit.

* Comb depth is adjusted to a maximum at f_1 by varying direct path resistor R (1,0 to 2,4 k Ω).
 ** Reflections are measured using a 5 μs long input pulse.
 ▲ Over the whole temperature range the comb depth at f_1 is $\geq 15 \text{ dB}$, and at f_+ and $f_- \geq 8 \text{ dB}$.

DELAY LINE

QUICK REFERENCE DATA

For video recorders to Brazilian PAL-M standard

Nominal frequency	3,575611 MHz
Phase delay time	128 μ s
Dimensions	37 x 7,5 x 28,5 mm
Self-extinguishing properties	

APPLICATION

The DL875 is for use in comb filter circuits of PAL-M video recorders.

DESCRIPTION

A very thin slab of zero TC glass provided with a split transducer is shock-proof mounted in a housing with self-extinguishing properties. Four pins enable the unit to be soldered directly onto a printed-wiring board.

MECHANICAL DATA
Outlines

Dimensions in mm

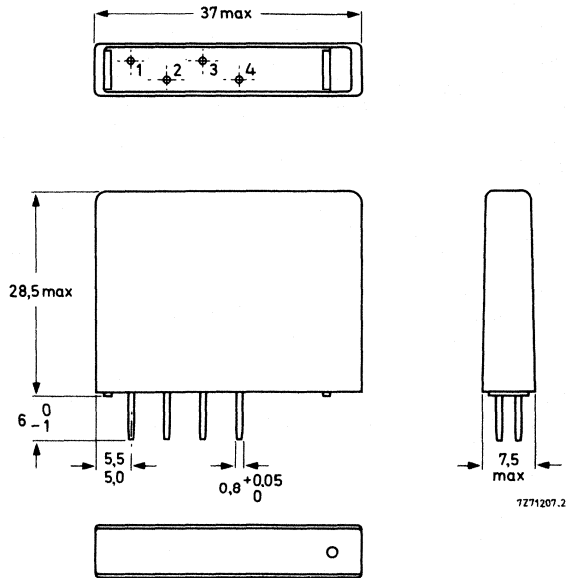

Fig. 1.

Mass 7 g

Mounting

The unit can be soldered directly onto a printed-wiring board.

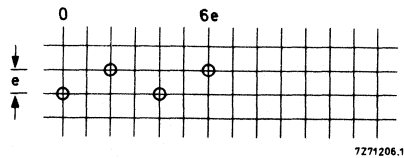

Fig. 2 Recommended hole pattern for mounting on a printed-wiring board; $e = 2,54$ mm. The tolerance on the distances of the different holes to the 0-line is $\pm 0,1$ mm. Hole diameter is $1,0 + 0,1$ mm.

ELECTRICAL DATA

Measured with the circuit of Fig. 3 at $25 \pm 5 \text{ }^\circ\text{C}$, R.H. = 40 to 60%.

Nominal frequency (f_0)		3,575611 MHz
Central comb frequency (f_1)		3,57168 MHz
Lower comb frequency (f_-)		3,07605 MHz
Upper comb frequency (f_+)		4,06731 MHz
Transducer attenuation at f_0		$18 \pm 3 \text{ dB}$
Comb depth at f_1 with respect to f_0 *	\geq	18 dB
Comb depth at f_- and f_+ with respect to f_0	\geq	10 dB
Phase delay time (τ)		128 μs
Bandwidth (-3 dB), measured with switch S open		$f_0 \pm 0,5 \text{ MHz}$
Maximum input voltage (p-p)		10 V
Spurious signals at the output, at f_0 **		
2 τ signals with respect to 1 τ signal	\leq	-15 dB
other signals with respect to 1 τ signal	\leq	-20 dB
Operating temperature range \blacktriangle		+10 to +60 $^\circ\text{C}$

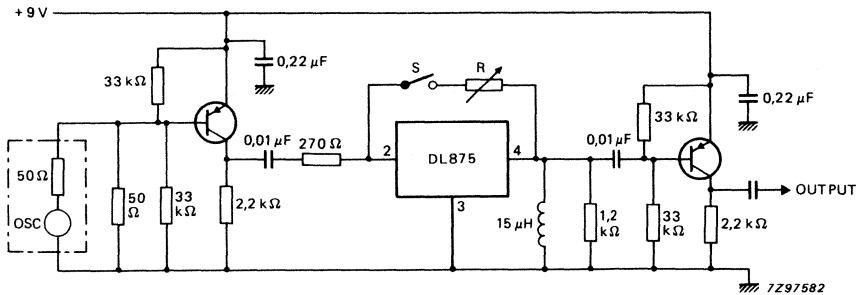

Fig. 3 Test circuit.

* Comb depth is adjusted to a maximum at f_1 by varying direct path resistor R (2,0 - 4,5 k Ω).
 ** Reflections are measured using a 5 μs long input pulse.
 \blacktriangle Over the whole temperature range the comb depth at f_1 is $\geq 15 \text{ dB}$, and at f_+ and $f_- \geq 8 \text{ dB}$.

DELAY LINE

QUICK REFERENCE DATA

For video recorders to Argentinian PAL-N standard

Nominal frequency 3,582056 MHz

Phase delay time 128 μ s

Dimensions 37 x 7,5 x 28,5 mm

Self-extinguishing properties

APPLICATION

The DL876 is for use in comb filter circuits of PAL-N video recorders.

DESCRIPTION

A very thin slab of zero TC glass provided with a split transducer is shock-proof mounted in a housing with self-extinguishing properties. Four pins enable the unit to be soldered directly onto a printed-wiring board.

MECHANICAL DATA

Dimensions in mm

Outlines

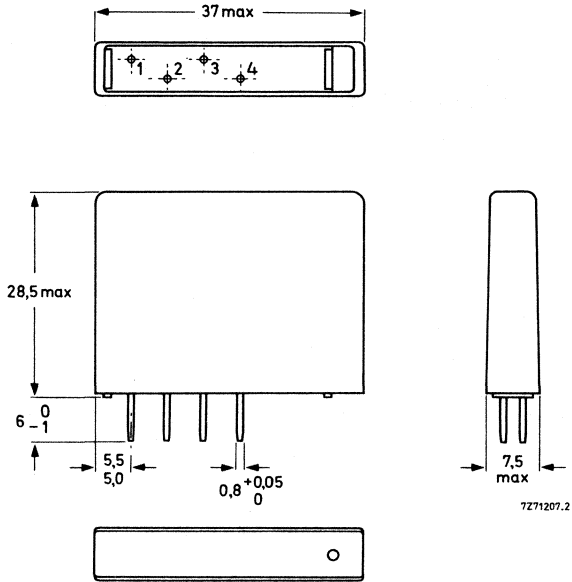

Fig. 1.

Mass 7 g

Mounting

The unit can be soldered directly onto a printed-wiring board.

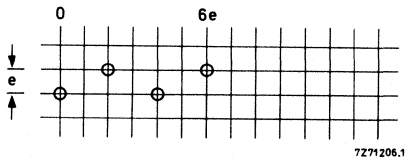

Fig. 2 Recommended hole pattern for mounting on a printed-wiring board; e = 2,54 mm. The tolerance on the distances of the different holes to the 0-line is $\pm 0,1$ mm. Hole diameter is $1,0 + 0,1$ mm.

ELECTRICAL DATA

Measured with the circuit of Fig. 3 at $25 \pm 5 \text{ }^\circ\text{C}$, R.H. = 40 to 60%.

Nominal frequency (f_0)		3,582056 MHz
Central comb frequency (f_1)		3,57815 MHz
Lower comb frequency (f_-)		3,08596 MHz
Upper comb frequency (f_+)		4,07034 MHz
Transducer attenuation at f_0		$18 \pm 3 \text{ dB}$
Comb depth at f_1 with respect to f_0^*	\geq	18 dB
Comb depth at f_- and f_+ with respect to f_0	\geq	10 dB
Phase delay time (τ)		128 μs
Bandwidth (-3 dB), measured with switch S open		$f_0 \pm 0,5 \text{ MHz}$
Maximum input voltage (p-p)		10 V
Spurious signals at the output, at f_0^{**}		
2τ signals with respect to 1τ signal	\leq	-15 dB
other signals with respect to 1τ signal	\leq	-20 dB
Operating temperature range \blacktriangle		+10 to +60 $^\circ\text{C}$

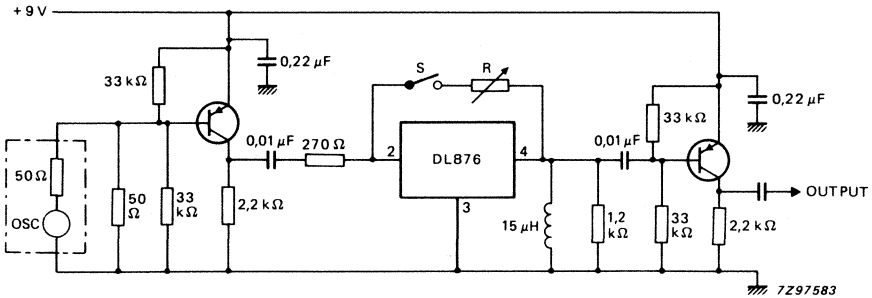

Fig. 3 Test circuit.

* Comb depth is adjusted to a maximum at f_1 by varying direct path resistor R (2,0 - 5,5 k Ω).
 ** Reflections are measured using a 5 μs long input pulse.
 \blacktriangle Over the whole temperature range the comb depth at f_1 is $\geq 15 \text{ dB}$, and at f_+ and $f_- \geq 8 \text{ dB}$.

COMB FILTER

QUICK REFERENCE DATA

For video recorders to European PAL standard

Nominal frequency	4,433619 MHz
Phase delay time	128 μ s
Dimensions	37 x 7,5 x 28,5 mm
Self-extinguishing properties	

APPLICATION

The CF873 is for use in comb filter circuits of PAL video recorders.

DESCRIPTION

A very thin slab of zero TC glass provided with a split transducer is shock-proof mounted in a housing with self-extinguishing properties. The filter incorporates a direct path resistor matched to the glass delay line which gives optimum combing properties. Four pins enable the unit to be soldered directly onto a printed-wiring board.

MECHANICAL DATA

Dimensions in mm

Outlines

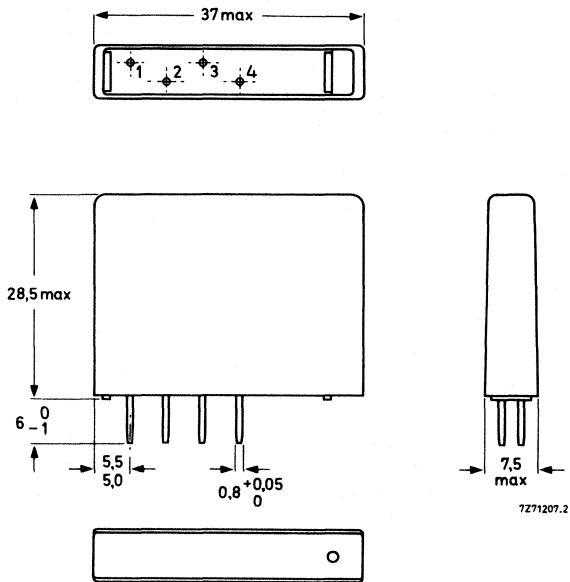

Fig. 1.

Mass 7 g

Mounting

The unit can be soldered directly onto a printed-wiring board.

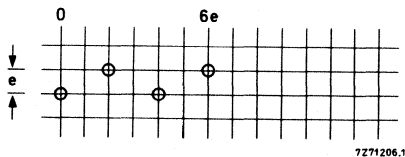

Fig. 2 Recommended hole pattern for mounting on a printed-wiring board; e = 2,54 mm. The tolerance on the distances of the different holes to the 0-line is ± 0,1 mm. Hole diameter is 1,0 + 0,1 mm.

ELECTRICAL DATA

Measured with the circuit of Fig. 3 at $25 \pm 5 \text{ }^\circ\text{C}$, R.H. = 40 to 60%.

Nominal frequency (f_0)	4,433619 MHz
Central comb frequency (f_1)	4,42971 MHz
Lower comb frequency (f_-)	3,92971 MHz
Upper comb frequency (f_+)	4,92971 MHz
Transducer attenuation at f_0	$18 \pm 3 \text{ dB}$
Comb depth at f_1 with respect to f_0	$\geq 20 \text{ dB}$
Comb depth at f_- and f_+ with respect to f_0	$\geq 12 \text{ dB}$
Phase delay time (τ)	$128 \text{ } \mu\text{s}$
Bandwidth (-3 dB), measured with pin 4 disconnected	$f_0 \pm 0,5 \text{ MHz}$
Maximum input voltage (p-p)	10 V
Spurious signals at the output, at f_0^*	
2 τ signals with respect to 1 τ signal	$\leq -18 \text{ dB}$
other signals with respect to 1 τ signal	$\leq -23 \text{ dB}$
Operating temperature range **	$+ 10 \text{ to } + 60 \text{ }^\circ\text{C}$

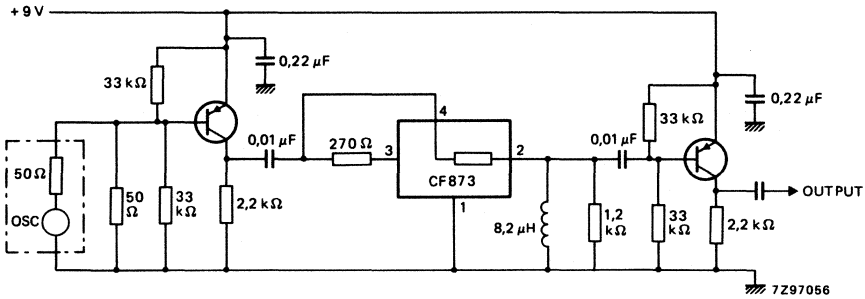

Fig. 3 Test circuit.

* Reflections are measured using a $5 \text{ } \mu\text{s}$ long input pulse.

** Over the whole temperature range the comb depth at f_1 is $\geq 15 \text{ dB}$, and at f_+ and $f_- \geq 8 \text{ dB}$.

DEGAUSSING COILS

16 inch
14 inch

3122 138 51850
3122 138 51860

DEGAUSSING COILS

- For 220/240 V mains voltage
- Double insulation

APPLICATION

For 14 in and 16 in, 90° colour picture tubes and high resolution data graphic display tubes. One coil asymmetrically mounted on the top and bottom of the cone of the tube, in conjunction with PTC thermistor 2322 662 98009, produces a decaying alternating field.

Degaussing coil 3122 138 51860 to be used with 14 in tubes, degaussing coil 3122 138 51850 to be used with 16 in tubes.

MECHANICAL DATA

Dimensions in mm

The coils of aluminium wire are completely sleeved with a flame-retardant foil; the coil ends are connected to pins in a holder. For connecting the coils to the circuit, a cable, length 40 cm, catalogue number 8222 289 36971 is available to special order.

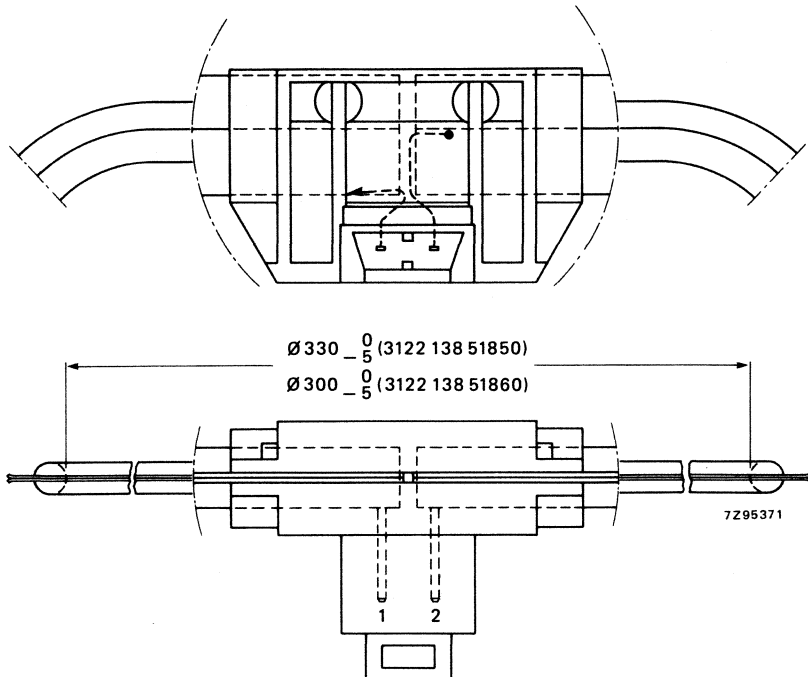

Fig. 1.

3122 138 51850
3122 138 51860

ELECTRICAL DATA

Coil resistance	
coil 3122 138 51850 (16 in)	26,3 $\Omega \pm 10\%$
coil 3122 138 51860 (14 in)	21,7 $\Omega \pm 10\%$
Number of turns	
coil 3122 138 51850 (16 in)	107
coil 3122 138 51860 (14 in)	97
Test voltage (d.c.)	
between interconnected pins and insulation foil	6000 V
between interconnected pins and holder	6000 V
Maximum working temperature	70 °C

20 and 22 inch
26 inch

3122 138 55220
3122 138 55230

DEGAUSSING COILS

- Single insulation

APPLICATION

For 26 in, 22 in and 20 in, 110° colour picture tubes. Two coils mounted on the top and bottom of the cone of the picture tube produce in conjunction with PTC thermistor 2322 662 98009 a decaying alternating field. The coils have to be connected in such a way that they operate magnetically in series, producing flux lines which flow from the top coil through the picture tube into the bottom coil or vice versa.

MECHANICAL DATA

Dimensions in mm

The coils are completely double sleeved with a flame-retardent foil; to guarantee mains isolation the coil ends are connected to a holder. For connecting the coils to the circuit, a cable, length 40 cm, catalogue number 8222 289 36971, is available to special order.

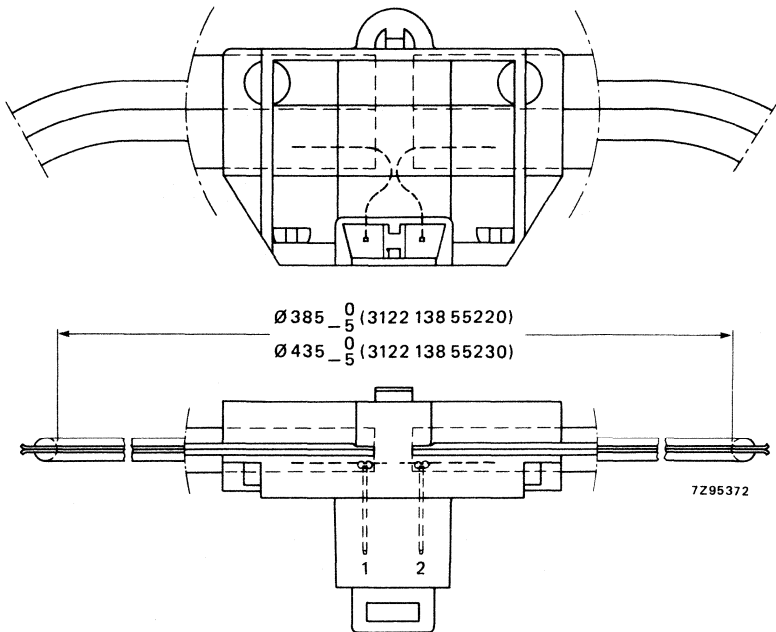

Fig. 1.

3122 138 55220
3122 138 55230

ELECTRICAL DATA

Coil resistance

coil 3122 138 55220 (20, 22 in)

11,5 Ω \pm 10%

coil 3122 138 55230 (26 in)

8,6 Ω \pm 10%

Number of turns

coil 3122 138 55220 (20, 22 in)

49

coil 3122 138 55230 (26 in)

52

Safety

according to IEC 65.10
and UL1410

Maximum working temperature

70 °C

DEGAUSSING COIL

- For 117 V and 220/240 V mains voltage
- Single coil
- Single insulation

APPLICATION

For 14 in, 90° colour picture tubes and high resolution data graphic display tubes. One coil asymmetrically mounted on the top and bottom of the cone of the tube, in conjunction with PTC thermistor 2322 662 98009, produces a decaying alternating field.

MECHANICAL DATA

Dimensions in mm

The coil of aluminium wire is completely sleeved with a flame-retardant foil; the coil ends are connected to pins in a holder. For connecting the coils to the circuit, a cable, length 40 cm, catalogue number 8222 289 36971 is available to special order.

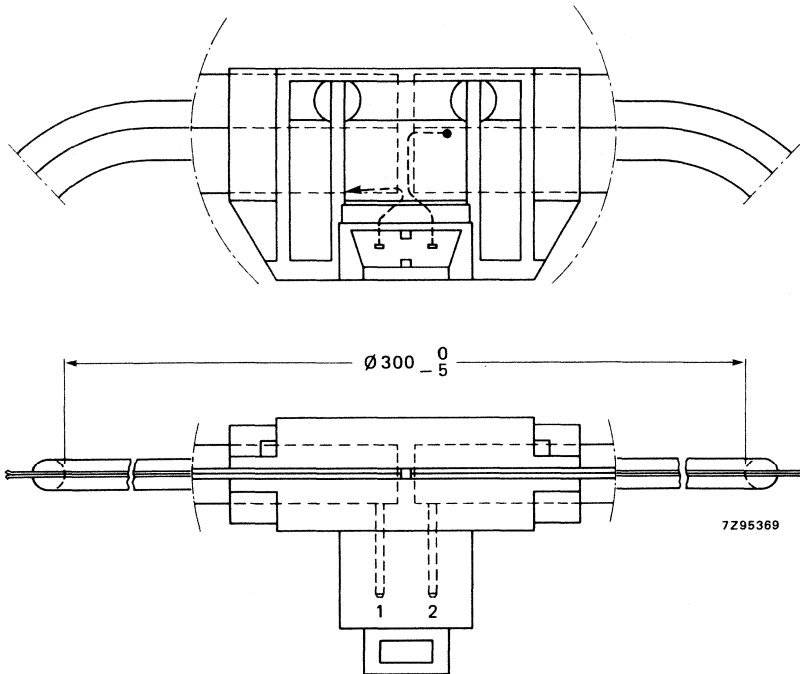

Fig. 1.

ELECTRICAL DATA

Coil resistance	14 Ω \pm 10%
Number of turns	134
Test voltage (d.c.)	
between interconnected pins and insulation foil	6000 V
between interconnected pins and holder	6000 V
Maximum working temperature	70 °C

DEGAUSSING COIL

- For 110 V and 220/240 V mains voltage
- Double insulation

APPLICATION

For 20 in, 90° colour picture tubes and high resolution data graphic display tubes. Two coils mounted on the top and bottom of the cone of the tube, in conjunction with PTC thermistor 2322 662 98009, produce a decaying alternating field.

MECHANICAL DATA

Dimensions in mm

The coil of aluminium wire is completely sleeved with a flame-retardant foil; the coil ends are connected to pins in a holder. For connecting the coils to the circuit, a cable, length 40 cm, catalogue number 8222 289 36971 is available to special order.

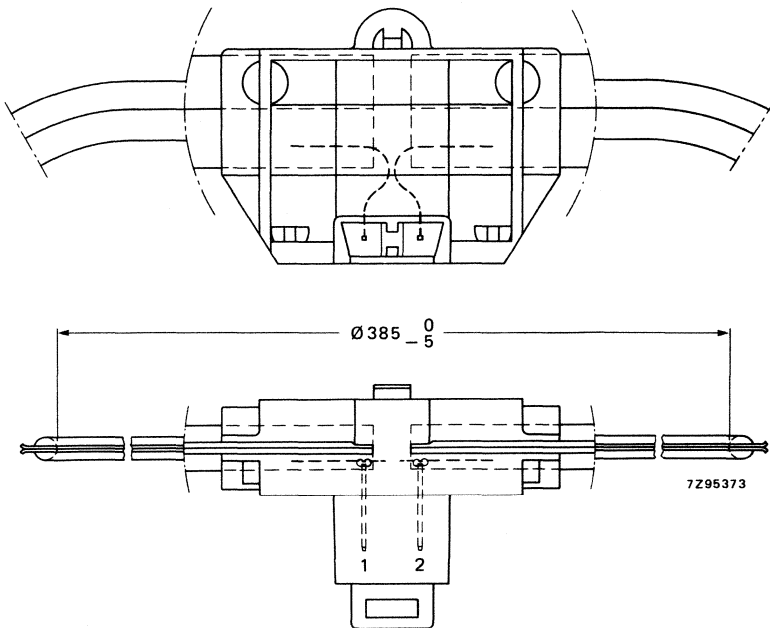

Fig. 1.

ELECTRICAL DATA

Coil resistance	11,4 Ω \pm 10%
Number of turns	65
Test voltage (d.c.) between interconnected pins and insulation foil between interconnected pins and holder	6000 V 6000 V
Safety	according to IEC 65.10 and UL 1410
Maximum working temperature	70 °C

DEGAUSSING COILS

- For 220/240 V mains voltage
- Coil 3122 138 56070 with single insulation,
coil 3122 138 56170 with double insulation

APPLICATION

For 20 in, 90° colour picture tubes and high resolution data graphic display tubes. One coil asymmetrically mounted on the top and bottom of the cone of the tube, in conjunction with PTC thermistor 2322 662 98009, produces a decaying alternating field.

MECHANICAL DATA

Dimensions in mm

The coils of aluminium wire are completely sleeved with a flame-retardant foil; the coil ends are connected to pins in a holder. For connecting the coils to the circuit, a cable, length 40 cm, catalogue number 8222 289 36971 is available to special order.

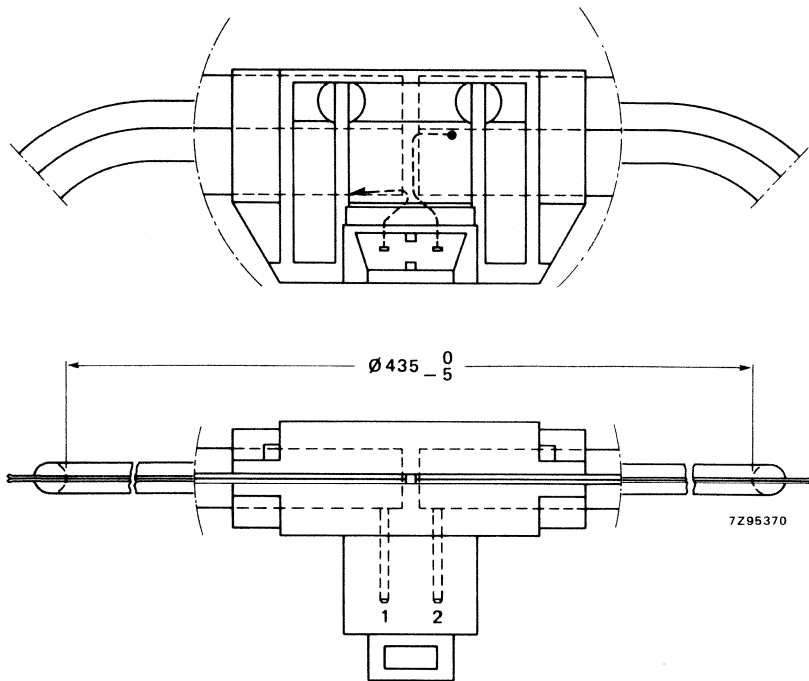

Fig. 1.

3122 138 56070
3122 138 56170

ELECTRICAL DATA

Coil resistance	19,5 Ω \pm 10%
Number of turns	120
Test voltage (d.c.) between interconnected pins and insulation foil	6000 V
between interconnected pins and holder	6000 V
Maximum working temperature	70 °C

DEGAUSSING COILS

- Double insulation

APPLICATION

For 26 in, 22 in and 20 in, 110° colour picture tubes. Two coils mounted on the top and bottom of the cone of the picture tube produce in conjunction with PTC thermistor 2322 662 98009 a decaying alternating field. The coils have to be connected in such a way that they operate magnetically in series, producing flux lines which flow from the top coil through the picture tube into the bottom coil or vice versa.

MECHANICAL DATA

Dimensions in mm

The coils are completely double sleeved with a flame-retardant foil; to guarantee mains isolation the coil ends are connected to a holder. For connecting the coils to the circuit, a cable, length 40 cm, catalogue number 8222 289 36971, is available to special order.

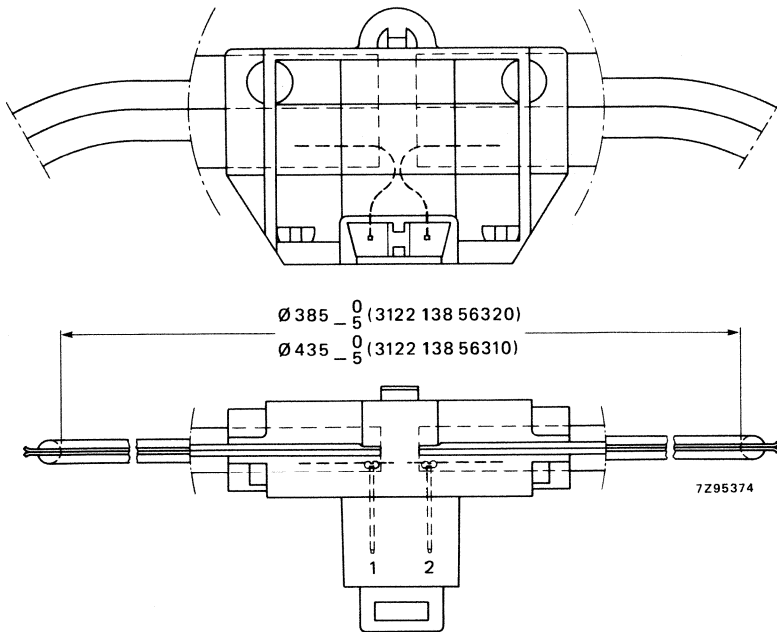

Fig. 1.

3122 138 56310
3122 138 56320

ELECTRICAL DATA

Coil resistance

coil 3122 138 56310 (26 in)

8,6 Ω \pm 10%

coil 3122 138 56320 (20, 22 in)

11,5 Ω \pm 10%

Number of turns

coil 3122 138 56310 (26 in)

52

coil 3122 138 56320 (20, 22 in)

49

Safety

according to IEC 65.10
and UL1410

Maximum working temperature

70 °C

14 inch
16 inch

3122 138 99840
3122 138 99850

DEGAUSSING COILS

- For 220/240 V mains voltage
- Single insulation

APPLICATION

For 14 in and 16 in, 90° colour picture tubes and high resolution data graphic display tubes. One coil asymmetrically mounted on the top and bottom of the cone of the tube, in conjunction with PTC thermistor 2322 662 98009, produces a decaying alternating field.

Degaussing coil 3122 138 99840 to be used with 14 in tubes, degaussing coil 3122 138 99850, to be used with 16 in tubes.

MECHANICAL DATA

Dimensions in mm

The coils of aluminium wire are completely sleeved with a flame-retardant foil; the coil ends are connected to pins in a holder. For connecting the coils to the circuit, a cable, length 40 cm, catalogue number 8222 289 36971, is available to special order.

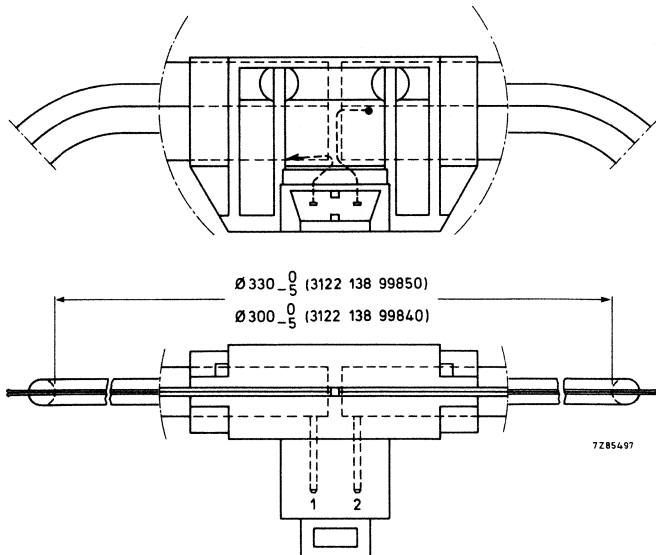

Fig. 1.

3122 138 99840
3122 138 99850

ELECTRICAL DATA

Coil resistance

coil 3122 138 99840 (14 in)	21,7 Ω \pm 10%
coil 3122 138 99850 (16 in)	26,3 Ω \pm 10%

Number of turns

coil 3122 138 99840 (14 in)	97
coil 3122 138 99850 (16 in)	107

Test voltage (d.c.)

between interconnected pins and insulation foil	6000 V
between interconnected pins and holder	6000 V

Maximum working temperature	70 °C
------------------------------------	--------------

TRANSFORMERS, CHOKES AND COILS

DEVELOPMENT DATA

This data sheet contains advance information and specifications are subject to change without notice.

AT3010/40

SWITCHED-MODE TRANSFORMER

- Aluminium foil winding
- Mains insulation
- 60 W output power
- 12 V/2 A, 5 V/3,5 A outputs

APPLICATION

This transformer is for use as a flyback switched-mode transformer for monochrome monitors with mains insulation.

MECHANICAL DATA

Dimensions in mm

The magnetic circuit of the transformer comprises two Ferroxcube U-cores with a rectangular leg, and a cylindrical leg on which the windings are situated.

The transformer has 11 pins for mounting on a printed-wiring board.

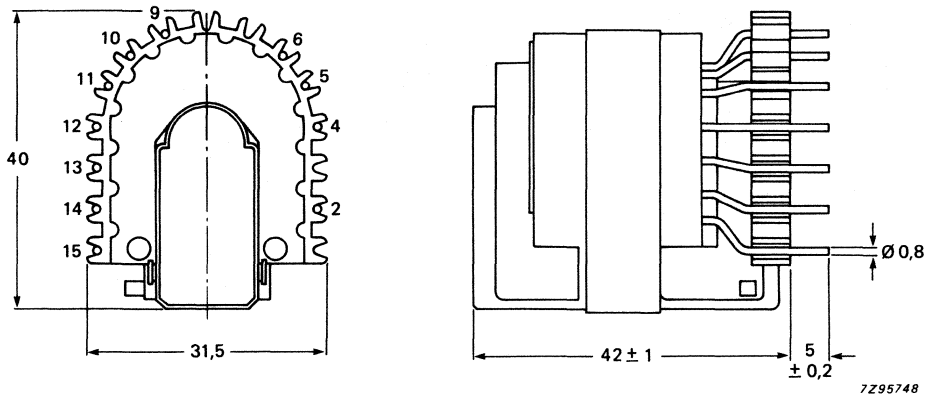

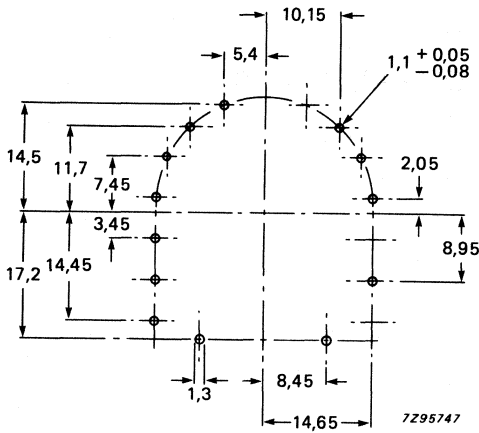

Fig. 2 Hole pattern for mounting on a printed wiring board (solder side).

ELECTRICAL DATA

Inductance, primary (4 - 6)*	1,2 mH ± 10%
Leakage inductance, primary (4 - 6)**	< 45 μH
Resistance, primary (4 - 6), at 25 °C	< 0,9 Ω
Resistance, secondary, at 25 °C	
(15 - 11)	< 0,05 Ω
(14 - 10)	< 0,05 Ω
(13 - 9)	< 0,13 Ω
(2 - 5)	< 0,085 Ω
Transformation ratio▲	
(4 - 6)/(15 - 11)	17,5 ± 5%
(4 - 6)/(14 - 10)	17,5 ± 5%
(4 - 6)/(13 - 9)	6,3 ± 5%
(4 - 6)/(2 - 5)	13,45 ± 5%
Test voltage (d.c.) for 1 min	
between primary and secondary	5600 V
between windings and core	500 V
Mains insulation	according to IEC 65, 14-3-1a, and UL 1410-1411
Maximum operating temperature	115 °C

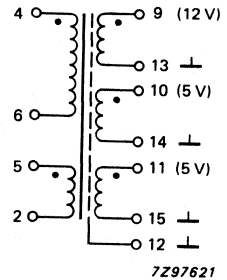

Fig. 3 Circuit diagram.
(The screen must be connected to the secondary ground.)

* At $f = 1 \text{ kHz}$, $I \geq 100 \text{ mA}$.
 ** At $f \geq 100 \text{ kHz}$, (13 - 9) short-circuited.
 ▲ At $V_{4-6} = 1 \text{ V}$, $f = 1 \text{ kHz}$.

DEVELOPMENT DATA

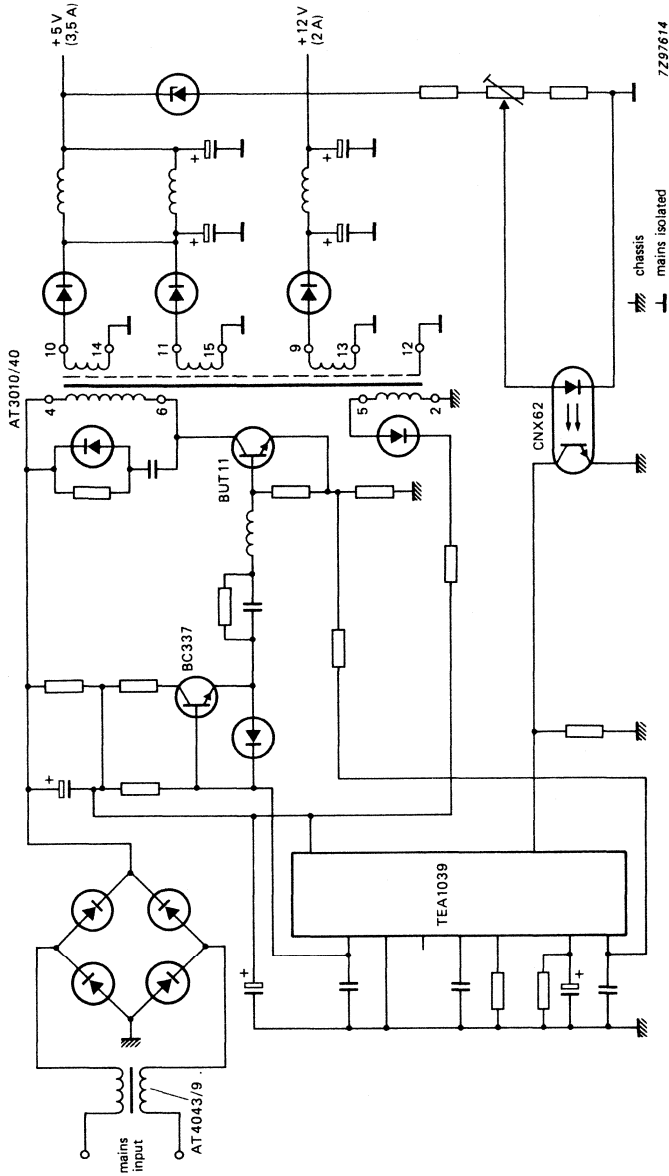

Fig. 4 Application circuit.

DEVELOPMENT DATA

This data sheet contains advance information and specifications are subject to change without notice.

AT3010/90L

SWITCHED-MODE TRANSFORMER

- Aluminium foil winding
- Mains insulation
- 55 W output power
- 105 V/0,4 A, 25 V/1 A, 15 V/0,6 A, 6 V/1 A outputs

APPLICATION

This transformer is for use as a flyback switched-mode transformer for 90° colour TV receivers and colour monitors with mains insulation.

It can be used in conjunction with line output transformer AT2079 (Micro slot).

MECHANICAL DATA

Dimensions in mm

The magnetic circuit of the transformer comprises two Ferroxcube U-cores with a rectangular leg, and a cylindrical leg on which the windings are situated.

The transformer has 13 pins for mounting on a printed-wiring board.

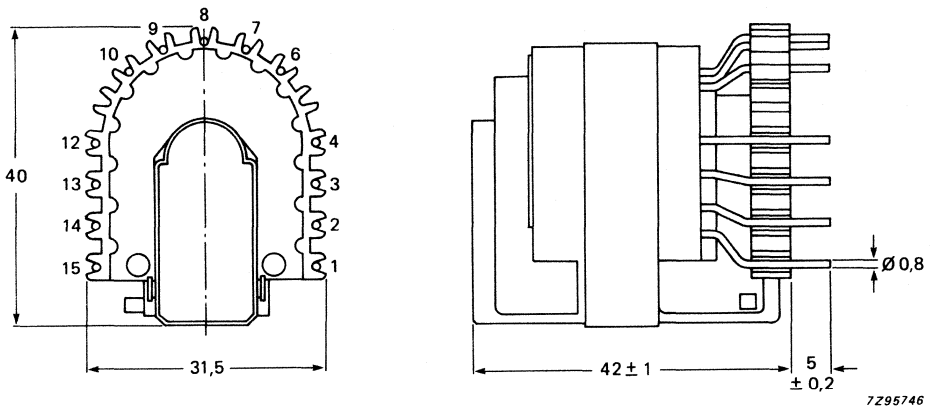

Fig. 1.

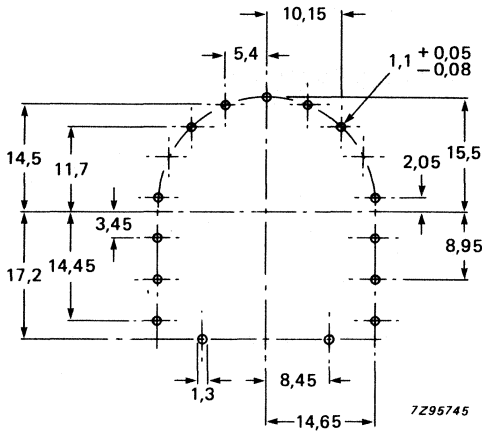

Fig. 2 Hole pattern for mounting on a printed wiring board (solder side).

ELECTRICAL DATA

Inductance, primary (10 - 9)*	1,15 mH ± 10%
Leakage inductance, primary (10 - 9)**	≤ 55 μH
Resistance, primary (10 - 9), at 25 °C	< 1 Ω
Resistance, secondary, at 25 °C	
(12 - 3)	< 0,18 Ω
(15 - 2)	< 0,06 Ω
(13 - 14)	< 1 Ω
Transformation ratio [▲]	
(10 - 9)/(12 - 3)	4,55 ± 5%
(10 - 9)/(15 - 2)	12,1 ± 5%
(10 - 9)/(13 - 1)	7,2 ± 5%
(10 - 9)/(13 - 14)	1,1 ± 5%
(10 - 9)/(8 - 6)	17 ± 5%
(10 - 9)/(6 - 7)	6,2 ± 5%

Test voltage (d.c.) for 1 min
 between primary and secondary
 between windings and core

5600 V
 500 V

Mains insulation

according to IEC 65,
 14-3-1a, and
 UL 1410-1411

Maximum operating temperature

115 °C

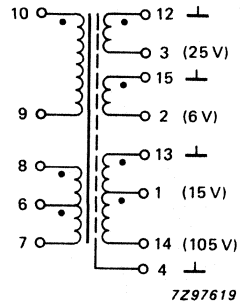

Fig. 3 Circuit diagram.
 (The screen must be connected to the secondary ground.)

* At f = 1 kHz, I ≥ 100 mA.

** At f ≥ 100 kHz, (13 - 14) short-circuited.

▲ V₁₀₋₉ = 1 V, f = 1 kHz.

DEVELOPMENT DATA

This data sheet contains advance information and specifications are subject to change without notice.

AT3010/110L

SWITCHED-MODE TRANSFORMER

- Aluminium foil winding
- Mains insulation
- 120 W or 70 W* output power
- 145 V/0,4 A, 25 V/0,25 A, 25 V/1 A, 15 V/0,6 A, 8 V/1 A outputs

APPLICATION

This transformer is for use as a flyback switched-mode transformer for 90° and 110° colour TV receivers and colour monitors with mains insulation.

MECHANICAL DATA

Dimensions in mm

The magnetic circuit of the transformer comprises two Ferroxcube ETD-cores with a rectangular leg, and a cylindrical leg on which the windings are situated.

The transformer has 14 pins for mounting on a printed-wiring board.

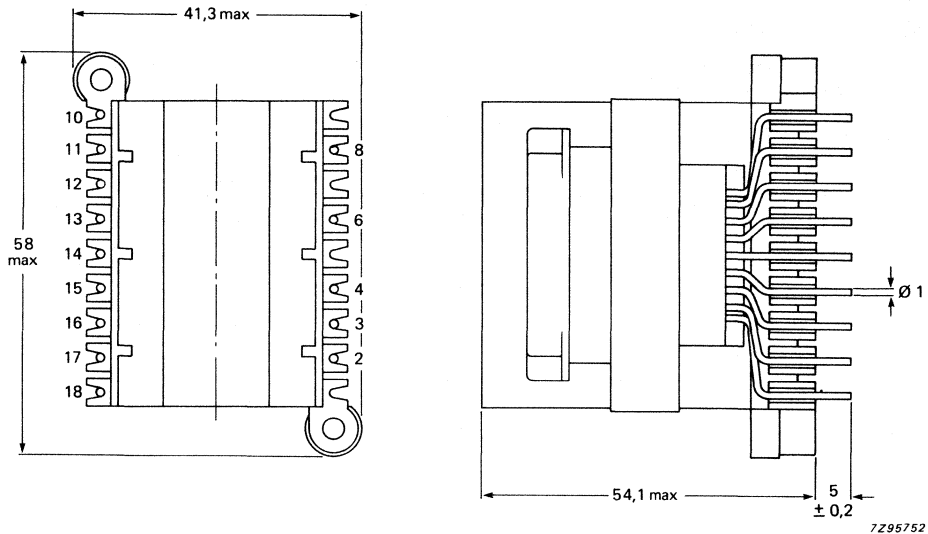

Fig. 1.

*At mains input voltage 90 to 264 V

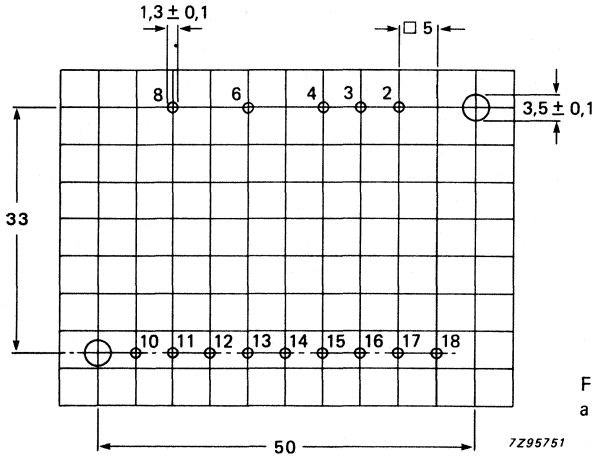

Fig. 2 Hole pattern for mounting on a printed wiring board (solder side).

ELECTRICAL DATA

Inductance, primary (6 - 8)*	1,08 mH ± 10%
Maximum current, primary (6 - 8)	3 A
Leakage inductance, primary (6 - 8)**	≤ 55 μH
Resistance, primary (6 - 8), at 25 °C	< 0,6 Ω
Resistance, secondary, at 25 °C	
(11 - 18)	< 0,06 Ω
(10 - 15)	< 0,05 Ω
(12 - 14)	< 0,3 Ω
Transformation ratio▲	
(8 - 6)/(11 - 18)	9,1 ± 5%
(8 - 6)/(10 - 15)	25 ± 5%
(8 - 6)/(12 - 16)	14,4 ± 5%
(8 - 6)/(12 - 14)	1,7 ± 5%
(8 - 6)/(2 - 4)	17 ± 5%
(8 - 6)/(4 - 3)	11,6 ± 5%
Test voltage (d.c.) for 1 min	
between primary and secondary	5600 V
between windings and core	500 V
Mains insulation	according to IEC 65, 14-3-1a, and UL 1410-1411
Maximum operating temperature	115 °C

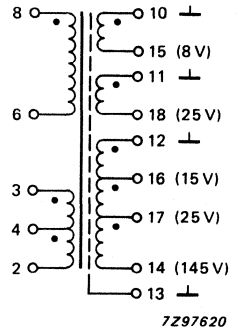

Fig. 3 Circuit diagram.
(The screen must be connected to the secondary ground.)

* At f = 1 kHz, I ≥ 100 mA.
 ** At f ≥ 100 kHz, (12 - 14) short-circuited.
 ▲ At V₆₋₈ = 1 V, f = 1 kHz.

DEVELOPMENT DATA

This data sheet contains advance information and specifications are subject to change without notice.

AT3010/110LS

SWITCHED-MODE TRANSFORMER

- Aluminium foil winding
- Mains insulation
- 120 W output power
- 145 V/0,4 A, 105 V/0,4 A, 25 V/0,11 A, 18 V/0,7 A, 8 V/0,2 A outputs

APPLICATION

This transformer is for use as a flyback switched-mode transformer for 90° and 110° colour TV receivers and colour monitors with mains insulation.

MECHANICAL DATA

Dimensions in mm

The magnetic circuit of the transformer comprises two Ferroxcube ETD-cores with a rectangular leg and a cylindrical leg on which the windings are situated.

The transformer has 15 pins for mounting on a printed-wiring board.

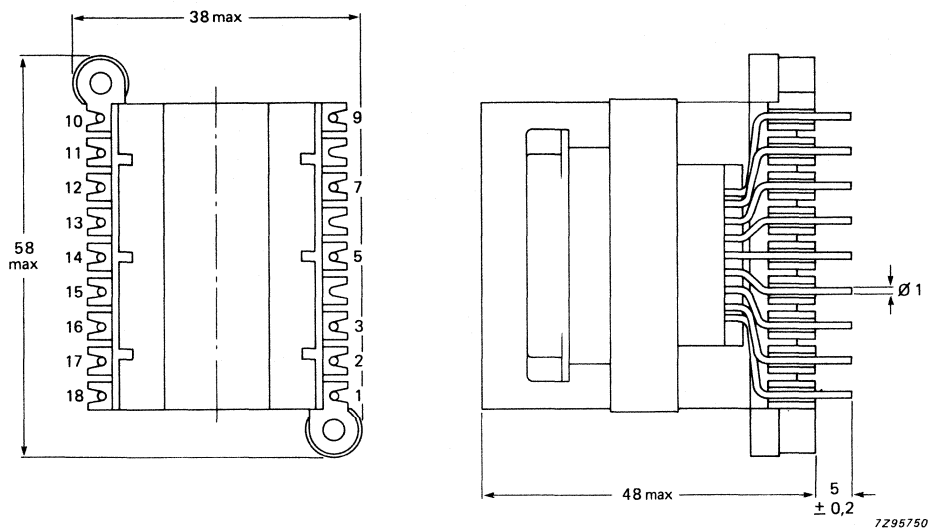

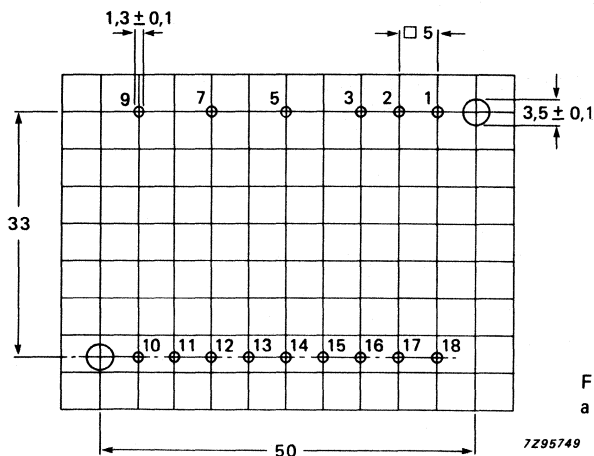

Fig. 2 Hole pattern for mounting on a printed wiring board (solder side).

ELECTRICAL DATA

Inductance, primary (7 - 5)*

1,7 mH ± 10%

Leakage inductance, primary (7 - 5)**

< 65 μH

Resistance, primary (7 - 5), at 25 °C

< 0,7 Ω

Resistance, secondary, at 25 °C

(10 - 12)

< 0,3 Ω

(11 - 12)

< 0,4 Ω

(13 - 18)

< 0,08 Ω

(14 - 17)

< 0,05 Ω

Transformation ratio[▲]

(7 - 5)/(3 - 2)

14,5 ± 5%

(7 - 5)/(2 - 1)

24,1 ± 5%

(7 - 5)/(12 - 16)

11,9 ± 5%

(7 - 5)/(12 - 11)

2,2 ± 5%

(7 - 5)/(12 - 10)

1,6 ± 5%

(7 - 5)/(14 - 17)

23,5 ± 5%

(7 - 5)/(13 - 18)

8,7 ± 5%

Test voltage (d.c.) for 1 min
between primary and secondary
between windings and core

5600 V

500 V

Mains insulation

according to IEC 65,

14-3-1a, and

UL 1410-1411

Maximum operating temperature

115 °C

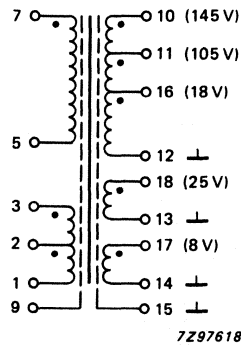

Fig. 3 Circuit diagram.

(The screen must be connected to the secondary ground.)

* At $f = 1 \text{ kHz}$, $I \geq 100 \text{ mA}$.

** At $f \geq 100 \text{ kHz}$, (10 - 12) short-circuited.

▲ At $V_{7.5} = 1 \text{ V}$, $f = 1 \text{ kHz}$.

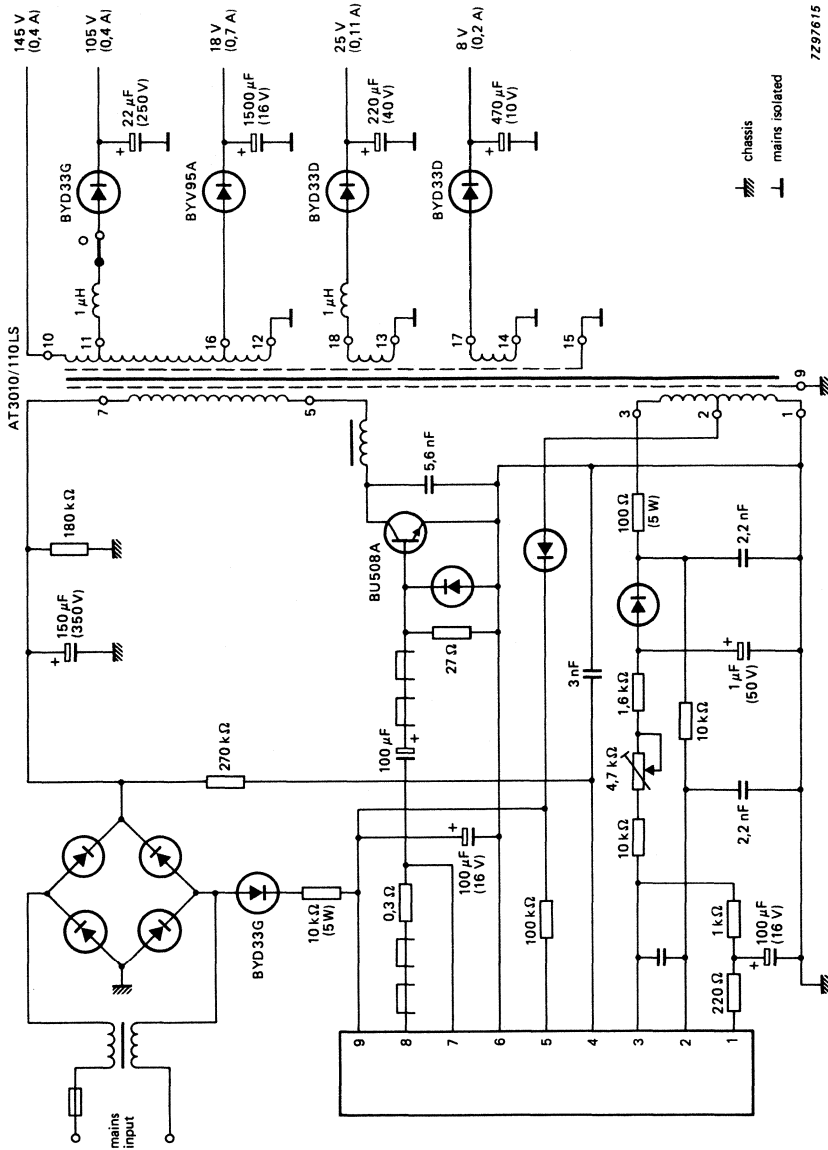

7297615

Fig. 4 Application circuit, with IC TDA4600.

LINE DRIVER TRANSFORMER

- For Colour Data Graphic Displays

APPLICATION

For drive of 1500 V transistors in line deflection and power supply circuits.

MECHANICAL DATA

Dimensions in mm

The magnetic circuit comprises two Ferroxcube U15 cores, grade 3C8. The transformer has four pins for mounting on a printed-wiring board, and a reference pin.

Outlines

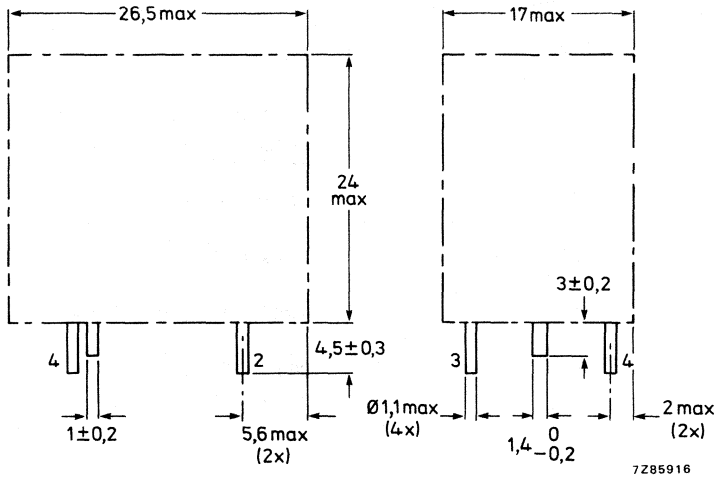

Fig. 1.

Mounting

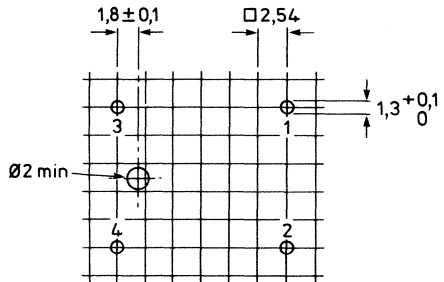
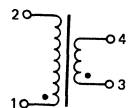

Fig. 2 Hole pattern for mounting on a printed-wiring board (component side).

ELECTRICAL DATA

Inductance, L_{2-1}	140 mH \pm 15%*
Resistance, R_{2-1} , at 25 °C	26,5 Ω \pm 12%
Leakage inductance, L_{3-4}	7,8 μ H**
Maximum permissible current, I_{2-1} (peak value)	40 mA
Resistance, R_{4-3} , at 25 °C	0,29 Ω \pm 12%
Voltage ratio, V_{2-1}/V_{4-3} , at $V_{2-1} = 1$ V, 1 kHz	15 \pm 5%
Test voltage (d.c.) between the windings, and between windings and core	2000 V
Ambient temperature range operating	-25 to +100 °C
storage	-40 to +115 °C
Inflammability	according to UL94 V-1



7285917

Fig. 3.

The transformer withstands the following tests:

test	IEC 68 test method	procedure
bump	Eb	1000 bumps, acceleration 245 m/s ² , 6 directions
vibration	Fc	10-55-10 Hz, ampl. 0,35 mm, 3 directions, 30 min/direction
damp heat, steady state	Ca	21 days, 40 °C, 93% R.H.
damp heat, cyclic	Db	21 days, 40 °C
change of temperature	Na	-25 °C, +100 °C; 5 cycles
dry heat	Bb	96 h, +100 °C
solderability	Ta	230 \pm 10 °C, 2 \pm 0,5 s

Reliability

Maximum cumulative percentage catastrophic failures after 300 h	\leq 0,01%
after 10 000 h	\leq 0,02%
after 30 000 h	\leq 1%

* Measured at 9 V, 1 kHz.

** Primary 2-1 short-circuited.

EAST/WEST CHOKE

- For Colour Data Graphic Displays

APPLICATION

The AT4043/08A is for use as an east/west choke in colour monitors.

MECHANICAL DATA

The magnetic circuit of the choke comprises two Ferroxcube U20 cores. The choke has four pins for mounting on a printed-wiring board.

Outlines

Dimensions in mm

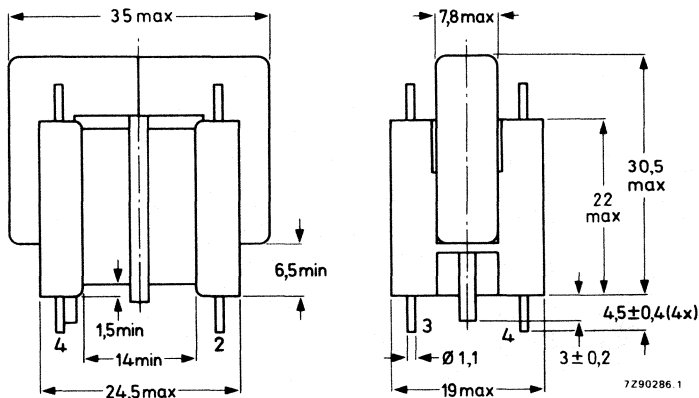

Fig. 1.

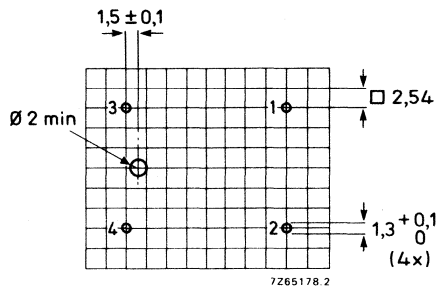
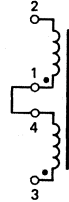

Fig. 2 Hole pattern for mounting on a printed-wiring board (component side).

ELECTRICAL DATA

Inductance, $L_{2,3}^*$	≥ 2 mH; typ. 2,6 mH
Resistance, $R_{2,3}^*$, at 25 °C	0,5 Ω
Maximum current (peak value)	0,7 A
Maximum working temperature	115 °C



7291458

Fig. 3.

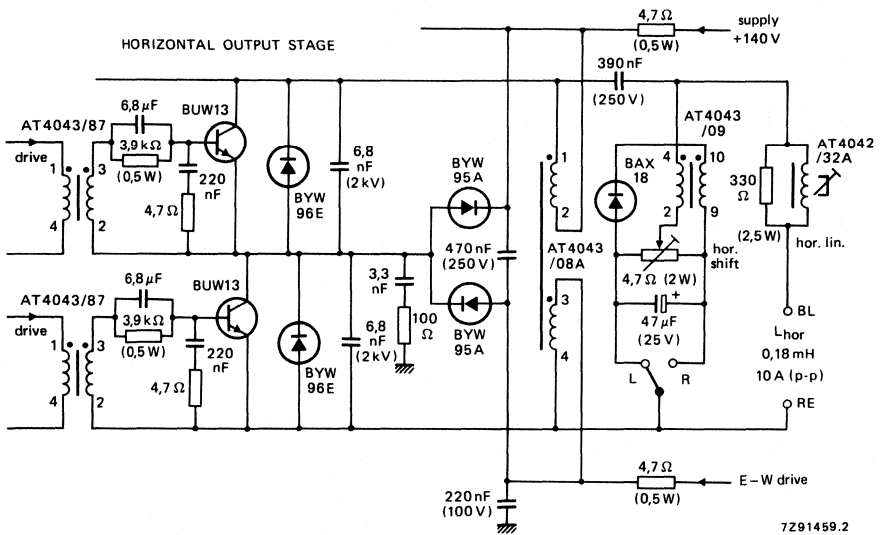

7291459.2

Fig. 4 Application circuit.

* Terminals 1 and 4 interconnected.

The choke withstands the following tests:

test	IEC 68 test method	procedure
bump	Eb	1000 bumps, acceleration 245 m/s ² , 6 directions
vibration	Fc	10-55-10 Hz, ampl. 0,35 mm, 3 directions, 30/min/direction
damp heat, steady state	Ca	21 days, 40 °C; 93% R.H.
damp heat, cyclic	Db	21 days, 40 °C
change of temperature	Na	-25 °C, + 100 °C; 5 cycles
dry heat	Bb	96 h, + 100 °C
solderability	Ta	230 ± 10 °C, 2 ± 0,5 s

Reliability

Maximum cumulative percentage catastrophic failures	
after 300 h	≤ 0,01%
after 10 000 h	≤ 0,02%
after 30 000 h	≤ 1%

UNIVERSAL HORIZONTAL SHIFT TRANSFORMER

- For Colour Data Graphic Displays

APPLICATION

This shift transformer is for use in colour data graphic display monitors.

MECHANICAL DATA

Dimensions in mm

The magnetic circuit comprises two Ferroxcube U25 cores, grade 3C8. The transformer has 10 pins for mounting on a printed-wiring board.

Outlines

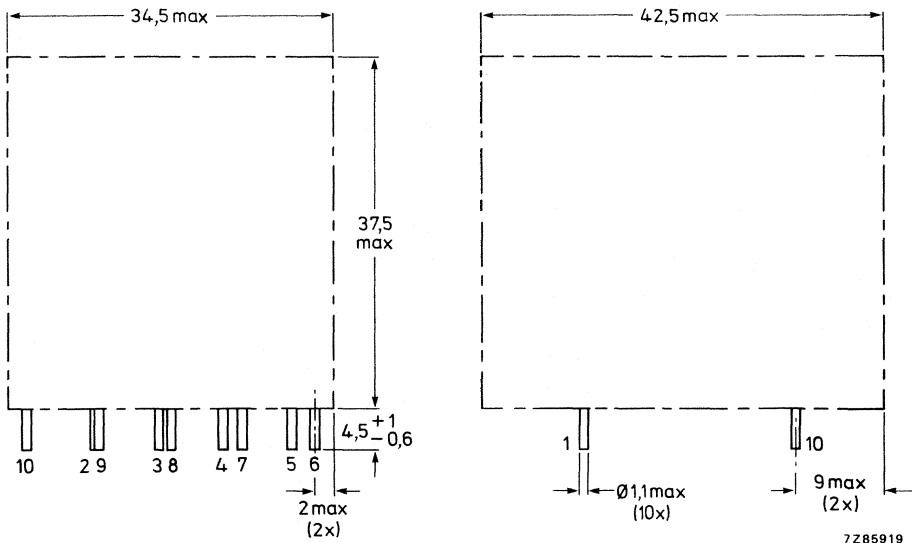
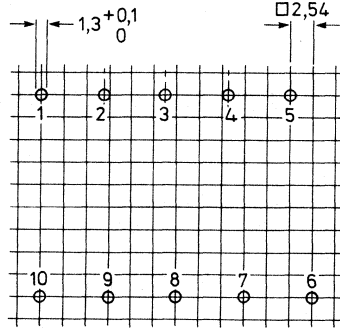

Fig. 1.

Mounting

Fig. 2 Hole pattern for mounting on a printed-wiring board (solder side).



ELECTRICAL DATA

Inductance, L_{5-1}^*

Resistance, R_{5-1} , at 25 °C

Resistance, R_{10-6} , at 25 °C

Voltage ratio*

V_{5-1}/V_{2-1}

V_{5-1}/V_{3-1}

V_{5-1}/V_{4-1}

V_{5-1}/V_{7-6}

V_{5-1}/V_{8-6}

V_{5-1}/V_{9-6}

V_{5-1}/V_{10-6}

Test voltage (d.c.) of winding 1-5 to winding 6-10 and core, for 1 min

Test voltage (d.c.) between winding 6-10 and core, for 1 min

Ambient temperature range operating

storage

Inflammability

150 mH ± 15%

$7,8 \Omega \pm 10\%$

$0,23 \Omega \pm 10\%$

$3,2 \pm 5\%$

$2,1 \pm 5\%$

$1,5 \pm 5\%$

$515 \pm 5\%$

$128,8 \pm 5\%$

$73,6 \pm 5\%$

$57,2 \pm 5\%$

2000 V

2000 V

-25 to + 100 °C

-40 to + 115 °C

according to UL94 V-1

7Z85920

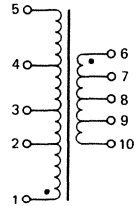

7Z85918

Fig. 3.

The transformer withstands the following tests:

test	IEC 68 test method	procedure
bump	Eb	1000 bumps, acceleration 245 m/s ² , 6 directions
vibration	Fc	10-55-10 Hz, ampl. 0,35 mm, 3 directions, 30 min/direction
damp heat, steady state	Ca	21 days, 40 °C, 93% R.H.
damp heat, cyclic	Db	21 days, 40 °C
change of temperature	Na	-25 °C, + 100 °C; 5 cycles
dry heat	Bb	96 h, + 100 °C
solderability	Ta	230 ± 10 °C, 2 ± 0,5 s

Reliability

Maximum cumulative percentage catastrophic failures

after 300 h ≤ 0,01%

after 10 000 h ≤ 0,02%

after 30 000 h ≤ 1%

* Measured at $V_{5-1} = 5 V$, 1 kHz.

INPUT CHOKE

- For 110° deflection colour TV in twin switch power pack system
- For 30 V/2 A audio power
- Mains insulation

APPLICATION

The AT4043/16A is for use as a supply choke in the twin switch power pack system (TSP²) for 110° colour TV receivers and colour monitors. It is used in conjunction with mains transformer TS561/2 or TS521B, mains filter choke AT4043/55, current sensing transformer AT4043/46, driver transformer AT4043/17 and diode-split line output transformer AT2077/82.

The secondary winding of the choke can be used for generating the stereo audio power in 110° colour TV receivers, up to 2 x 15 W.

MECHANICAL DATA

Dimensions in mm

The magnetic circuit comprises two Ferroxcube E42 cores, grade 3C8. The choke has 11 pins for mounting on a printed-wiring board.

Outlines

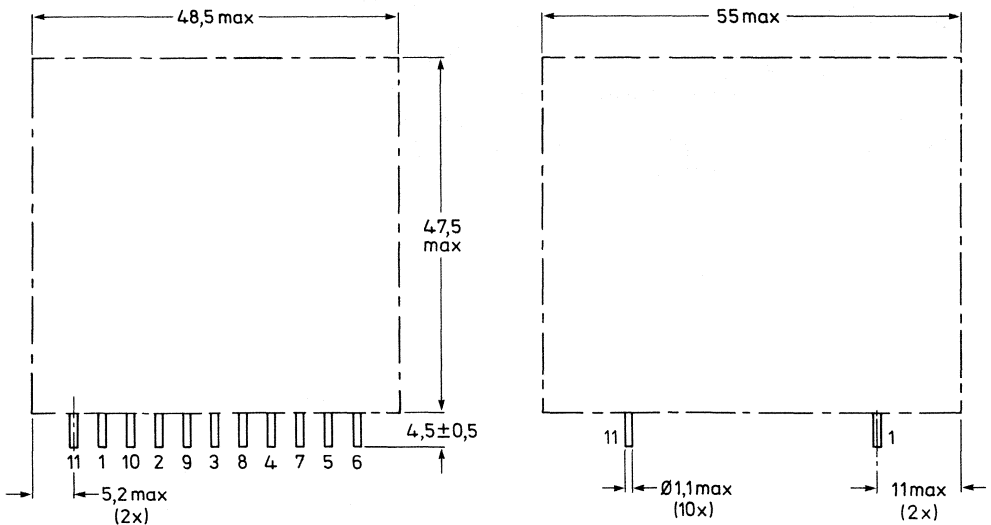

Fig. 1.

7285915

Mounting

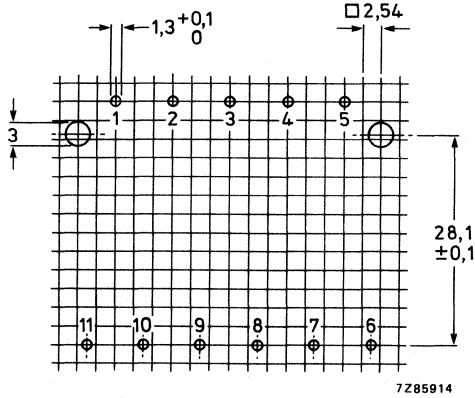
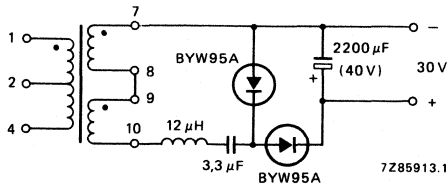

Fig. 2 Hole pattern for mounting on a printed-wiring board (solder side).

7Z85914

ELECTRICAL DATA

Inductance, L ₁₋₄ *	14 mH ± 10%
Resistance, R ₁₋₂	0,44 Ω ± 12%
Resistance, R ₂₋₄	0,98 Ω ± 12%
Resistance, R ₇₋₈	68 mΩ ± 12%
Resistance, R ₉₋₁₀	68 mΩ ± 12%
Turns ratio 1-4/7-8	27,7 ± 5%
Turns ratio 1-4/9-10	27,7 ± 5%
Test voltage (d.c.) of winding 1-4 to winding 7-10 and core for 1 min	5600 V
Test voltage (d.c.) of winding 7-10 to core for 1 min	500 V
Maximum operating temperature	115 °C
Inflammability	according to UL94 V-1



7Z85913.1

Fig. 3.

* Measured at 17,2 V, 1 kHz.

The choke withstands the following tests:

test	IEC 68 test method	procedure
bump	Eb	1000 bumps, acceleration 245 m/s ² , 6 directions
vibration	Fc	10-55-10 Hz, ampl. 0,35 mm, 3 directions, 30 min/direction
damp heat, steady state	Ca	21 days, 40 °C, 93% R.H.
damp heat, cyclic	Db	21 days, 40 °C
change of temperature	Na	-25 °C, + 100 °C; 5 cycles
dry heat	Bb	96 h, + 100 °C
solderability	Ta	230 ± 10 °C, 2 ± 0,5 s

Reliability

Maximum cumulative percentage catastrophic failures

after 300 h	≤ 0,01%
after 10 000 h	≤ 0,02%
after 30 000 h	≤ 1%

DRIVER TRANSFORMER

- For 110° deflection colour TV in twin single switch power pack system
- Mains insulation

APPLICATION

The AT4043/17 is for use as a power supply and line driver transformer in the twin switch power pack system (TSP²) for 110° colour TV receivers and colour monitors. It is used in conjunction with mains transformer TS561/2 or TS5621B, mains filter choke AT4043/55, current sensing transformer AT4043/46, input choke AT4043/16A and diode-split line output transformer AT2077/82.

MECHANICAL DATA

Dimensions in mm

The magnetic circuit comprises two Ferroxcube U20 cores, grade 3C8. The primary and secondary windings are wound in a two-part coil former with large creepage distances and clearances, which ensure safe insulation between the mains and control circuits. The transformer has six pins for mounting on a printed-wiring board, and one lead (connecting point 7).

Outlines

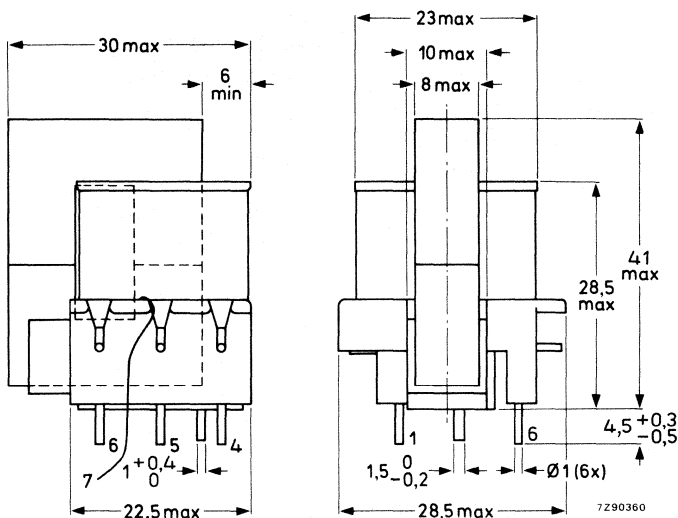
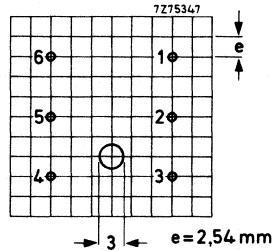

Fig. 1.

Mounting

Fig. 2 Hole pattern for mounting on a printed-wiring board (component side); hole diameter is $1,3 \pm 0,1$ mm.



ELECTRICAL DATA

Inductance, L_{5-4}	≥ 11 mH*
Resistance, R_{5-4} , at 25 °C	$0,21 \Omega \pm 12\%$
Resistance, R_{1-2} , at 25 °C	$0,17 \Omega \pm 12\%$
Resistance, R_{6-7} , at 25 °C	$7,0 \Omega \pm 12\%$
Turns ratio 1-2/5-4	0,17
Turns ratio 1-2/6-7	1,0
Maximum primary current (peak value)	240 mA
Test voltage (d.c.) of winding 1-2 to winding 5-4 and core for 1 min	5600 V
Test voltage (d.c.) of winding 5-4 to core for 1 min	500 V
Ambient temperature range	
operating	-25 to +80 °C
storage	-40 to +100 °C
Inflammability	according to UL94 V-1

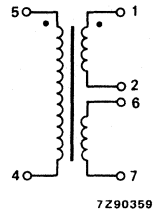

Fig. 3.

The transformer withstands the following tests:

test	IEC 68 test method	procedure
bump	Eb	1000 bumps, acceleration 400 m/s ² , 6 directions
vibration	Fc	10-55-10 Hz, ampl. 0,35 mm 3 directions, 30 min/direction
damp heat, steady state	Ca	21 days, 40 °C, 93%, R.H.
damp heat, cyclic	Db	21 days, 40 °C
change of temperature	Na	-25 °C, +85 °C; 5 cycles
dry heat	Bb	96 h, +100 °C
Solderability	Ta	230 ± 10 °C, 2 ± 0,5 s

Reliability

Maximum cumulative percentage catastrophic failures	
after 300 h	$\leq 0,01\%$
after 10 000 h	$\leq 0,02\%$
after 30 000 h	$\leq 1\%$

* Measured at 4,4 V, 1 kHz.

LINE DRIVER/D.C. SHIFT TRANSFORMER

APPLICATION

This line driver, or d.c. shift, transformer, is for all transistor colour television receivers and monochrome data graphic display monitors.

MECHANICAL DATA

Dimensions in mm

The magnetic circuit comprises two Ferroxcube U20 cores, grade 3C8. The transformer has four connecting pins and a location pin for mounting on a printed-wiring board.

Outlines

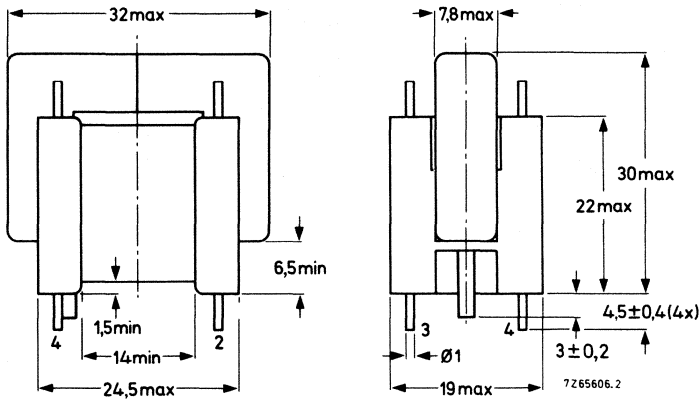

Fig. 1.

Mounting

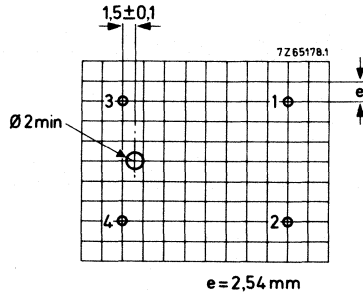
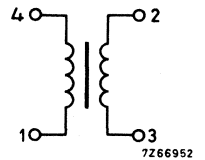

Fig. 2 Hole pattern for mounting on a printed-wiring board, hole diameter $1,3 + 0,1$ mm.

ELECTRICAL DATA

Inductance primary (1-4)
 Leakage inductance secondary (2-3)*
 Resistance secondary (2-3) at 25 °C
 Transformation ratio 4-1/2-3
 Maximum working temperature

370 mH ± 12%
 14 μH ± 20%
 0,35 Ω
 31 : 1
 100 °C



* Primary short circuited.

SWITCHED-MODE DRIVER TRANSFORMER with mains isolation

APPLICATION

The transformer AT4043/45 has been designed for use as a driver transformer in the synchronous power pack system for colour tv receivers with mains isolation. It is used in conjunction with current sensing transformer AT4043/46 and mains transformer TS561/2.

MECHANICAL DATA

Dimensions in mm

The magnetic circuit of the transformer comprises two Ferroxcube U20-cores. Two separate coil formers guarantee the required isolation between primary and secondary. The transformer is provided with 6 pins for mounting on a printed-wiring board.

Outlines

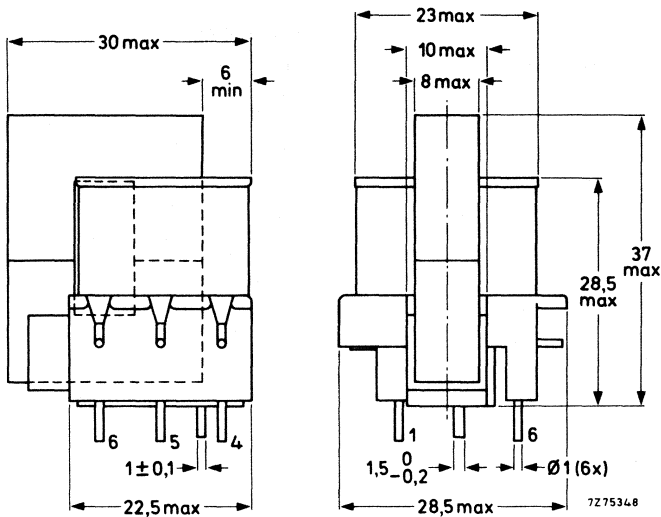
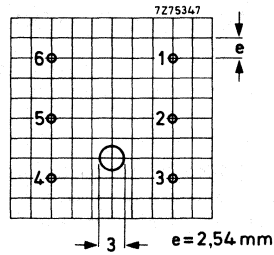

Fig. 1.

Mounting

Fig.2 Hole pattern for mounting on a printed-wiring board; hole diameter 1,3 + 0,1 mm. Viewed from the component side.



ELECTRICAL DATA

Inductance, primary	(4 - 6)	$\geq 16 \text{ mH}^*$
Resistance at 25 °C	(4 - 6)	$2 \Omega \pm 12\%$
Leakage inductance, secondary	(1 - 3)	$\leq 6 \mu\text{H}^{**}$
Resistance at 25 °C	(1 - 3)	$0,05 \Omega \pm 12\%$
Turns ratio		5 : 1
Mains isolation		acc. to IEC 65
Maximum working temperature		115 °C

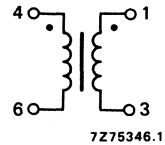

Fig. 3.

* Measuring condition: E = 8 V, f = 1 kHz.

** Measuring condition (primary short-circuited): $E \leq 250 \text{ mV}$, $0,9 \text{ MHz} \leq f \leq 1,1 \text{ MHz}$.

CURRENT SENSING TRANSFORMER with mains isolation

APPLICATION

The transformer AT4043/46 has been designed for use as a sensing transformer in switched-mode power supply circuits.

MECHANICAL DATA

The magnetic circuit of the transformer comprises two Ferroxcube U15-cores. The primary turn is potted in the coil former to guarantee the required isolation. The transformer is provided with 4 pins for mounting on a printed-wiring board.

Outlines

Dimensions in mm

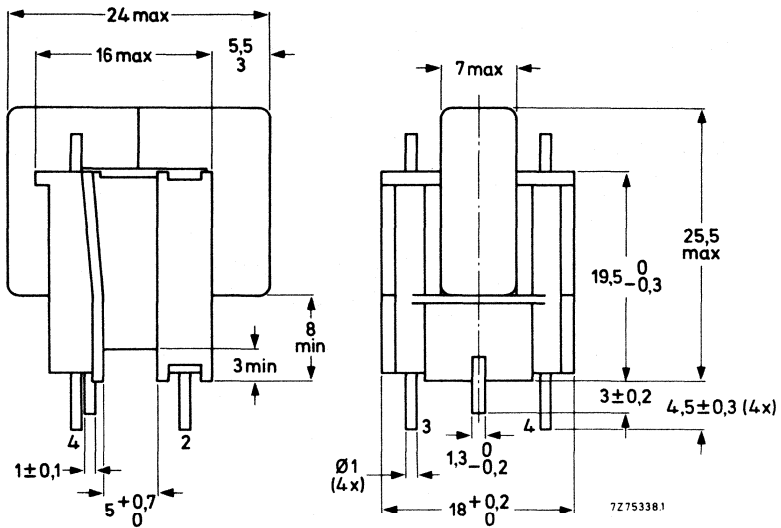
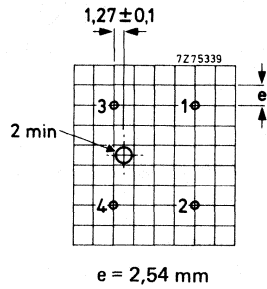

Fig.1

Mounting

Fig.2 Hole pattern for mounting on a printed-wiring board; hole diameter $1,3 + 0,1$ mm. Viewed from the component side.



ELECTRICAL DATA

Inductance, secondary	(3 - 4)	≥ 700 mH *
Resistance, secondary, at 25 °C	(3 - 4)	$65 \Omega \pm 12\%$
Turns ratio		1 : 800
Mains isolation		acc. to IEC 65
Maximum working temperature		115 °C

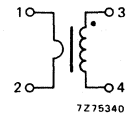

Fig.3

APPLICATION CIRCUIT

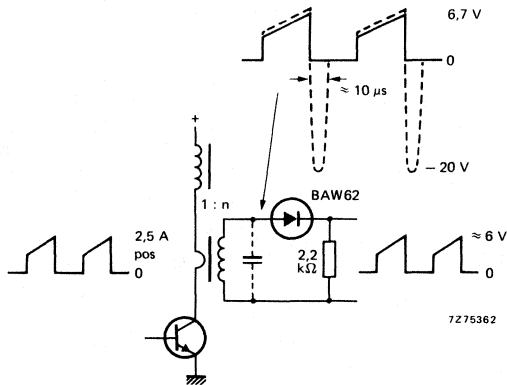

Fig. 4.

* Measuring condition: $E = 10$ V, $f = 1$ kHz.

CURRENT SENSING TRANSFORMER

with mains isolation

APPLICATION

The AT4043/47 is a current sensing transformer in professional switched-mode power supply circuits. It can also be used as a measuring device in many applications.

MECHANICAL DATA

Dimensions in mm

The ungapped magnetic circuit of the transformer comprises two Ferroxcube U15-cores in grade 3C8. The primary turn is potted in the coil former to guarantee the required isolation. The transformer is provided with 4 pins for mounting on a printed-wiring board.

Outlines

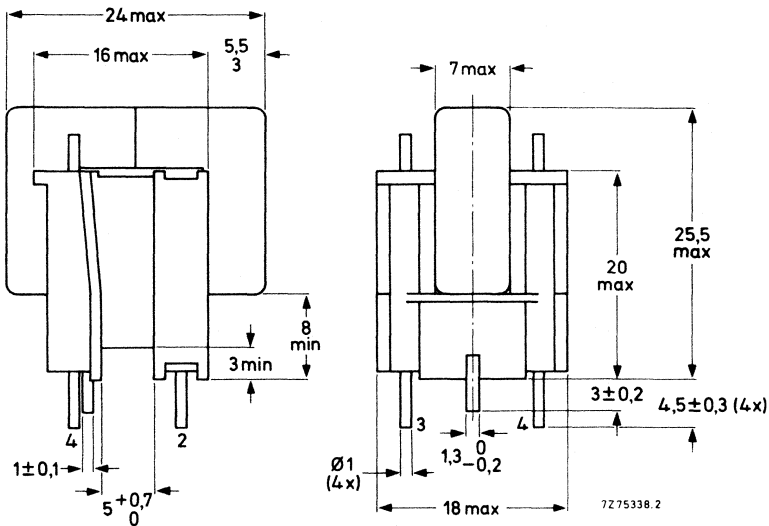
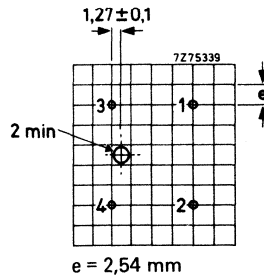

Fig. 1.

Mounting

Fig. 2 Hole pattern for mounting on a printed-wiring board; hole diameter $1,3 \pm 0,1$ mm. Viewed from the component side.



ELECTRICAL DATA

Inductance, secondary	(4 - 3)	$\geq 12,5 \text{ mH}^*$
Resistance, secondary, at 25 °C	(4 - 3)	$1 \Omega \pm 12\%$
Number of turns		1 prim., 100 sec.
Mains isolation at 5600 V d.c.		acc. to IEC 435
Maximum working temperature		115 °C
Inflammability		acc. to UL94V-1

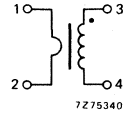
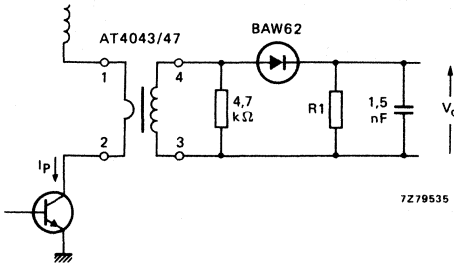

Fig. 3.

APPLICATION CIRCUIT



typical values				
I_p A	V_o V	R1 Ω	t_p μs	droop %
10	1	10	20	3
5	1	22	20	5
2,5	1	39	20	10
2,5	1	39	10	5

Fig. 4.

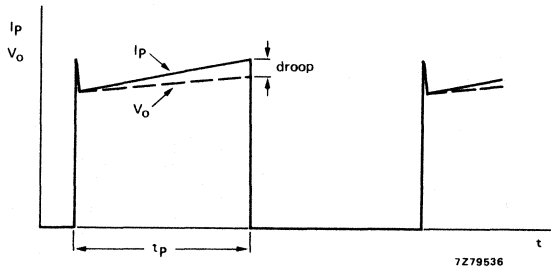

Fig. 5.

* Measuring condition: $E = 1,3 \text{ V}$; $f = 1 \text{ kHz}$.

The transformer withstands the following tests:

test	IEC68 test method	procedure
bump	Eb	1000 bumps, acceleration 40g, 6 directions
vibration	Fc	freq. 10-55-10 Hz, ampl. 0,75 mm, 6 directions, 30 min/direction
damp heat, steady state	Ca	21 days 40 °C; 93% R.H.
damp heat, cyclic	Db	21 days 40 °C
change of temperature	Na	-25 °C, +125 °C; 5 cycles
dry heat	Bb	16 h + 125 °C
solderability	T	230 ± 10 °C, 2 ± 0,5 s

THYRISTOR TRIGGER AND TRANSISTOR DRIVER TRANSFORMERS

- Mains isolation

APPLICATION

These transformers have been designed for use as thyristor and triac trigger transformers in professional applications where highly reliable primary to secondary voltage isolation is required, and as transistor driver transformers typically for use in switched-mode power supplies.

MECHANICAL DATA

Dimensions in mm

The magnetic circuits of the transformers comprise two Ferroxcube U20 cores in grade 3C8. Type AT4043/48 is ungapped, type AT4043/63 has two 60 μm gap spacers. The primary and secondary windings are wound on a two-part coil former with large creepage and clearance distances which ensure very safe isolation between mains and control circuits. The transformers are provided with pins for mounting on a printed-wiring board.

Outlines

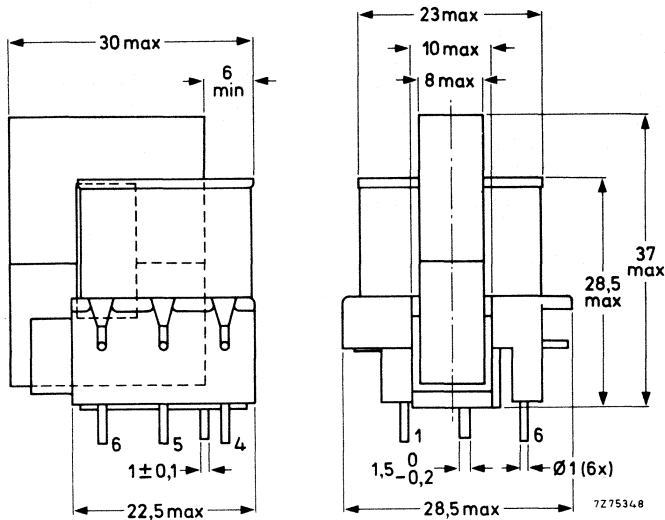

Fig. 1.

Mounting

Fig. 2 Hole pattern for mounting on a printed-wiring board; hole diameter 1,3 + 0,1 mm. Viewed from the component side.

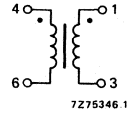
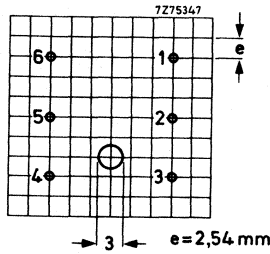

Fig. 3.

ELECTRICAL DATA (see Fig. 3)

	AT4043/48	AT4043/63
Inductance primary * (4 - 6)	≥ 6 mH	$\geq 1,9$ mH
Resistance at 25 °C (4 - 6)	$0,9 \Omega \pm 12\%$	$0,9 \Omega \pm 12\%$
Inductance, secondary (1 - 3)	0,66 mH	0,22 mH
Resistance at 25 °C (1 - 3)	$0,05 \Omega \pm 12\%$	$0,05 \Omega \pm 12\%$
Leakage inductance primary, secondary short-circuited **	$\leq 60 \mu\text{H}$	
Leakage inductance secondary, primary short-circuited **	$\leq 6 \mu\text{H}$	
Turns ratio 4-6/3-1	3/1	
Maximum Et product	1 mWb	
Maximum primary current (r.m.s.) for non-simultaneous switching	1 A	
Test voltage (d.c.) of winding 1-3 to winding 4-6 and core for 1 min	5600 V	
Test voltage (d.c.) of winding 4-6 to core for 1 min	500 V	
Ambient temperature range		
operating	-25 to +80 °C	
storage	-40 to +100 °C	
Inflammability	acc. to UL94 V-1	

* Measuring condition: E = 1,5 V, f = 1 kHz.

** Measuring condition: E \leq 250 mV; $0,8 \text{ MHz} \leq f \leq 1 \text{ MHz}$.

Environmental tests

The transformers withstand the following tests:

test	IEC68 test method	procedure
bump	Eb	1000 bumps, acceleration 40g, 6 directions
vibration	Fc	freq. 10-55-10 Hz, ampl. 0,75 mm 3 directions, 30 min/direction
damp heat, steady state	Ca	21 days, 40 °C, 93% R.H.
damp heat, cyclic	Db	21 days, 40 °C
change of temperature	Na	-25 °C, +125 °C, 5 cycles
dry heat	Bb	16 h, +125 °C
solderability	T	230 ± 10 °C, 2 ± 0,5 s

APPLICATION CIRCUITS

Type AT4043/48 used as a thyristor trigger transformer. This transformer is suitable for triggering all our thyristors and triacs.

Typical operating conditions:

Rise time	≤ 0,5 μs
Pulse duration	15 μs
Duty factor	0,25
Trigger peak current	750 mA

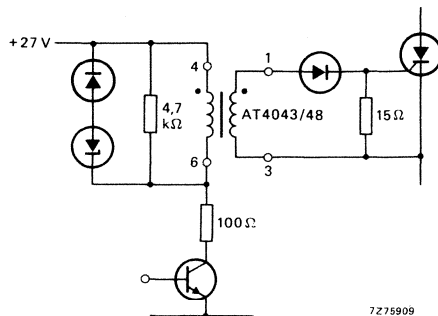

Fig. 4 Typical circuit.

Type AT4043/48 or type AT4043/63 as a transistor driver transformer.

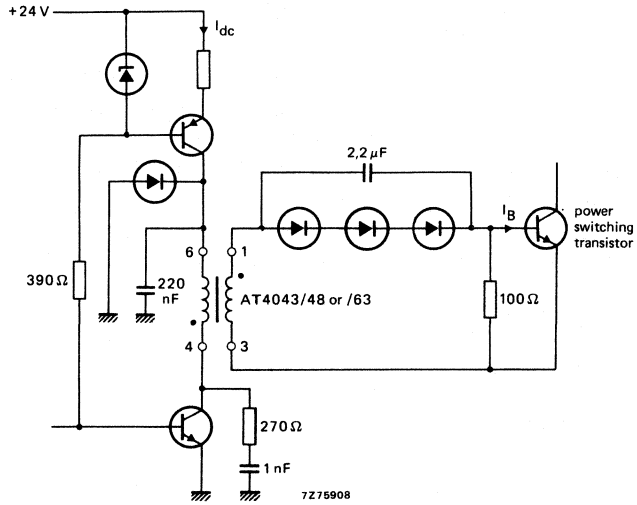

Fig. 5 Typical circuit.

Typical operating conditions:

AT4043/48

frequency kHz	I_{dc} mA	I_{B1} A	I_{B2} A
20	160	0,9	0,4
50	230	1,0	0,7

AT4043/63

frequency kHz	I_{dc} mA	I_{B1} A	I_{B2} A
20	310	1,5	1,0
50	290	1,2	1,0

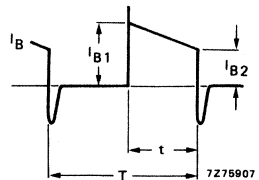

Fig. 6 $\frac{t}{T} = 0,4$.

POWER PACK SYSTEM SUPPLY CHOKE

- For Colour Television

APPLICATION

The DT4043/52A is for use as a supply choke in a power pack system for colour TV receivers. It is used in conjunction with mains transformer TS61/2, mains filter choke AT4043/55, current sensing transformer AT4043/46, line choke AT4043/53 and synchronous power pack transformer AT2076/70A.

MECHANICAL DATA

Dimensions in mm

The magnetic circuit comprises two Ferroxcube U25 cores, grade 3C8. The choke has 10 pins ($\phi 1 + 0,1$ mm, length $4,5 \pm 0,5$ mm) for mounting on a printed-wiring board. The maximum height of the choke is 36 mm.

Mounting

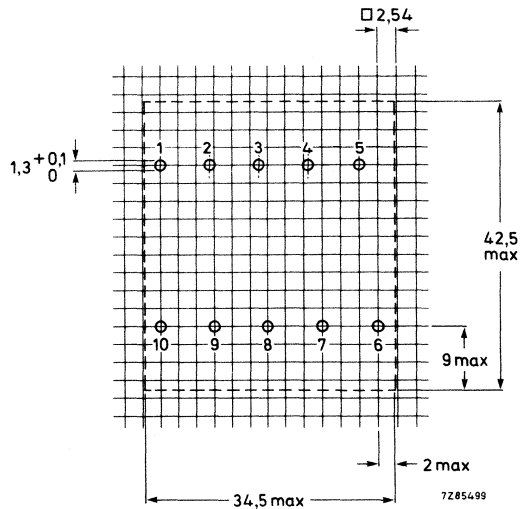

Fig. 1 Hole pattern for mounting on a printed-wiring board, viewed from the solder side.

ELECTRICAL DATA

Inductance, L_{g-2}	9 mH $\pm 10\%$
Resistance, R_{g-2}	2,3 $\Omega \pm 12\%$
Maximum peak current	1,4 A
Maximum working temperature	115 °C
Flammability	according to UL94, category V-1

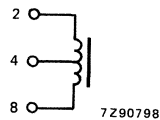

Fig. 2.

POWER PACK SYSTEM LINE CHOKE

for colour television

APPLICATION

The AT4043/53 has been designed for use as a line choke in a power pack system in conjunction with mains transformer TS561/2, power pack transformer AT2076/70A, etc. (see data on relevant transformer).

MECHANICAL DATA

Dimensions in mm

The magnetic circuit of the line choke comprises two Ferroxcube U-cores. The unit is provided with pins for mounting on a printed-wiring board.

Outlines

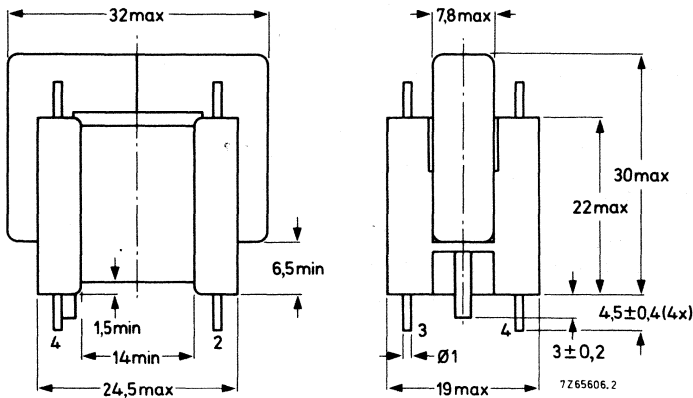

Fig. 1.

Mounting

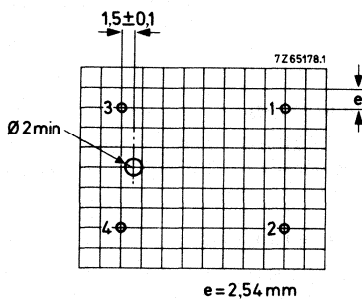

Fig. 2 Hole pattern for mounting on a printed-wiring board, viewed from component side. Hole diameter $1,3 + 0,1$ mm.

ELECTRICAL DATA

Inductance (1-2)*	12 mH \pm 10%
Resistance (1-2)	9,2 Ω \pm 10%
Maximum peak current (1-2)	525 mA
Turns ratio 1-3/1-2	0,32
Maximum working temperature	115 °C
Inflammability	UL94V-1
Corona test voltage at 70 kHz	1700 V peak

With the choke connected in the line timebase circuit with deflection unit AT1270, AT1260 or AT1250:

Deflection current p-p	5,35 A
Flyback time	11,5 μ s

BU208A

V_{CEM}	1150 V
I_C	3,1 A

With deflection unit AT1035/00:

Deflection current p-p	2,85 A
Flyback time	11,6 μ s

BU205 or BU208A

V_{CEM}	1000 V
I_C	1,7 A

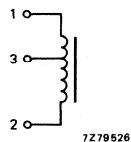

Fig. 3.

* Measuring condition: $E = 1$ V, $f = 1$ kHz.

APPLICATION CIRCUITS

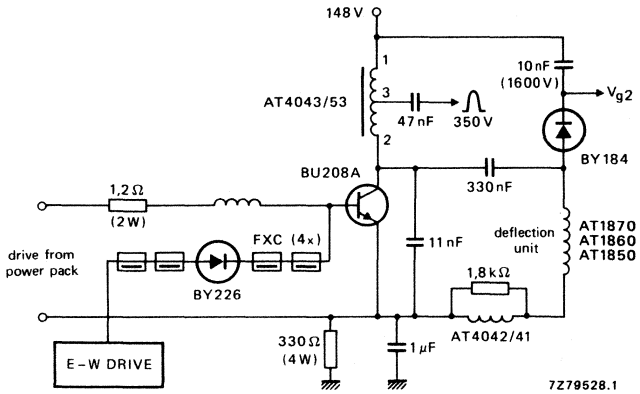

Fig. 4 Circuit for 110° deflection.

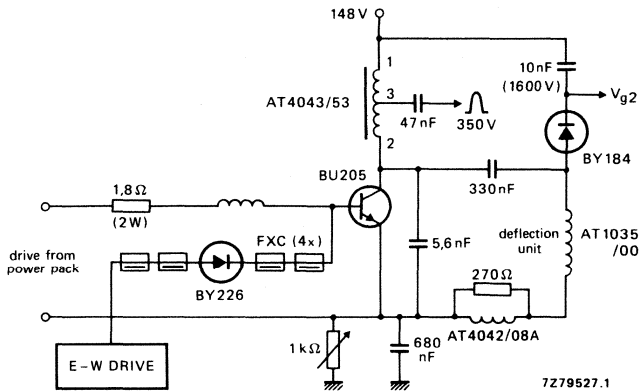

Fig. 5 Circuit for 90° deflection.

MAINS FILTER CHOKE FOR 1,5 A rms

APPLICATION

The AT4043/55 has been designed for use in consumer and professional equipment as part of the filter network in the power supply.

MECHANICAL DATA

The magnetic circuit of the filter choke comprises two Ferroxcube U25 cores. The unit is provided with four pins for mounting on a printed-wiring board.

Outlines

Dimensions in mm

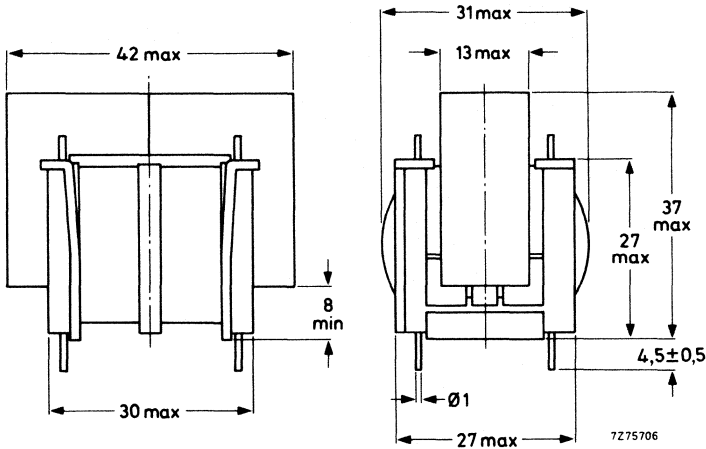
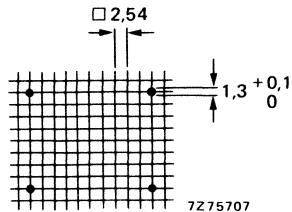

Fig. 1.

Fig. 2 Hole pattern for mounting on a printed-wiring board. Viewed from the solder side. The windings may be interchanged because the coil is symmetrical.



Marking

The catalogue number is printed on the Ferroxcube core.

ELECTRICAL DATA

Inductance, $L_{1-2} = L_{3-4}$	≥ 25 mH
Resistance, $R_{1-2} = R_{3-4}$, at 25 °C	0,5 Ω
Leakage inductance	
$L_S(1-2)$, L_{3-4} short-circuited	0,65 mH
$L_S(3-4)$, L_{1-2} short-circuited	0,65 mH
Capacitance	37 pF
Maximum current (r.m.s.)	2 A
Maximum working temperature	115 °C

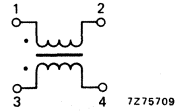

Fig. 3.

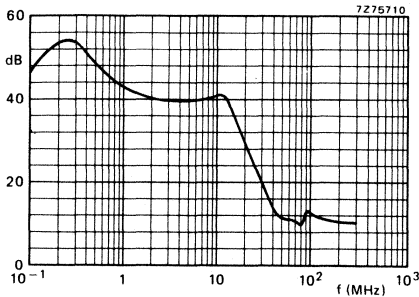

Fig. 4 Insertion loss measured in the 60 Ω circuit of Fig. 5.

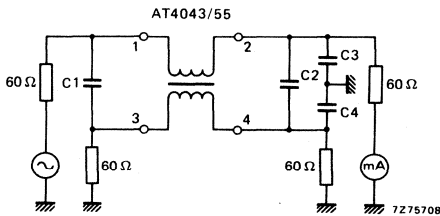

Fig. 5
 $C_1 = C_3 = C_4 = 2200$ pF, 250 V.
 $C_2 = 0,47$ μ F, 250 V.

LINE DRIVER TRANSFORMER

- For Monochrome Data Graphic Displays

APPLICATION

This transformer has been designed for use in monochrome monitors. The required supply voltage is 12 V. The transformer is used in conjunction with deflection unit AT1071/03 or AT1074, line-output transformer AT2102/02, and linearity control unit AT4036/00A.

MECHANICAL DATA

Dimensions in mm

The magnetic circuit of the transformer comprises two Ferroxcube U-cores. The unit is provided with pins for mounting on a printed-wiring board.

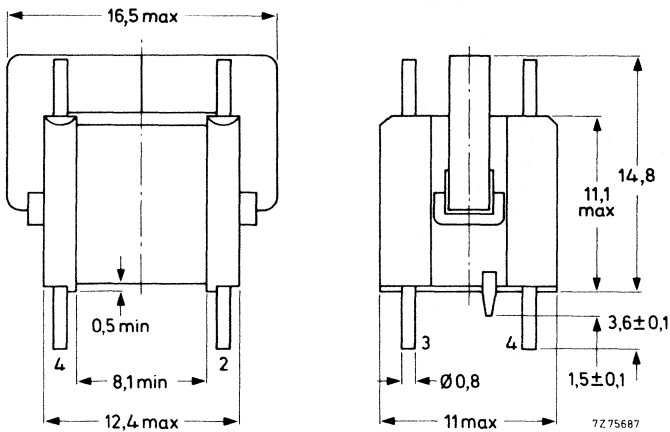
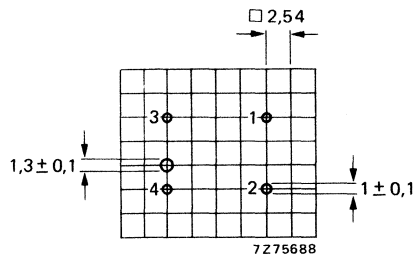

Fig. 1 Line driver transformer AT4043/56.

Fig. 2 Hole pattern for mounting on a printed-wiring board (component side).



ELECTRICAL DATA

Inductance (primary, 1-2)	5,8 mH \pm 15%
Inductance (secondary)	\leq 10 μ H
Transformation ratio	4 : 1
Maximum operating temperature	95 $^{\circ}$ C

Application circuit

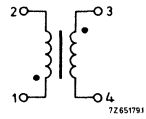

Fig. 3 Circuit diagram.

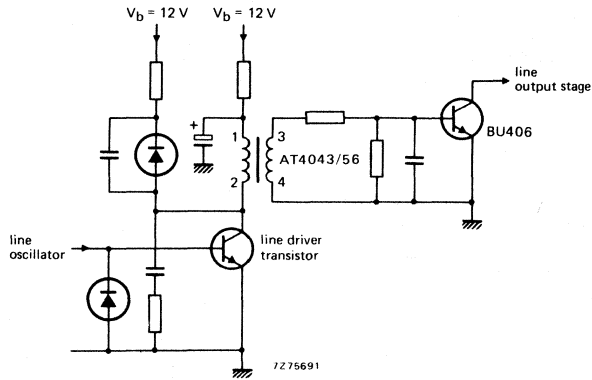

Fig. 4.

LINE DRIVER TRANSFORMER

- For Monochrome Data Graphic Displays

APPLICATION

This transformer has been designed for use in monochrome monitors. The required supply voltage is 24 V. The transformer is used in conjunction with deflection unit AT1038/40A, line-output transformer AT2102/04C and linearity control unit AT4042/08A.

MECHANICAL DATA

Dimensions in mm

The magnetic circuit of the transformer comprises two Ferroxcube U-cores. The unit is provided with pins for mounting on a printed-wiring board.

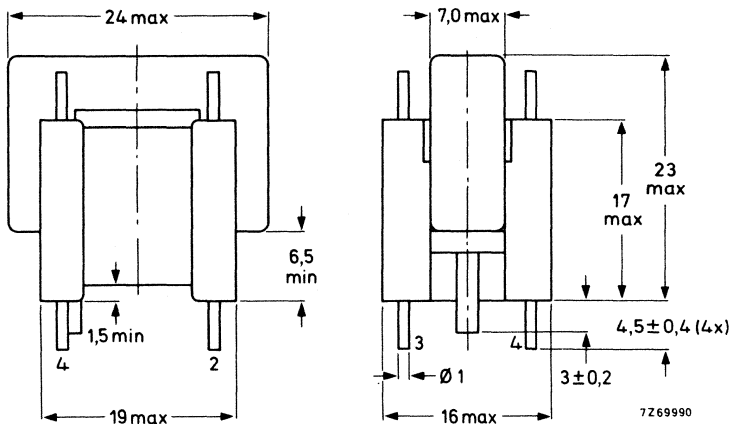

Fig. 1 Line driver transformer AT4043/59.

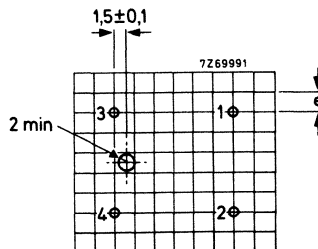

Fig. 2 Hole pattern for mounting on a printed-wiring board (component side). Hole diameter $1,3 \pm 0,1$ mm. $e = 2,54$ mm (0,1 in).

ELECTRICAL DATA

Inductance (primary, 1-2)	6,1 mH
Leakage inductance (secondary)	12 μ H \pm 15%
Transformation ratio	4,18 : 1
Maximum operating temperature	95 $^{\circ}$ C

Application circuit

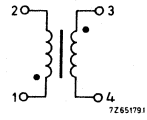

Fig. 3 Circuit diagram.

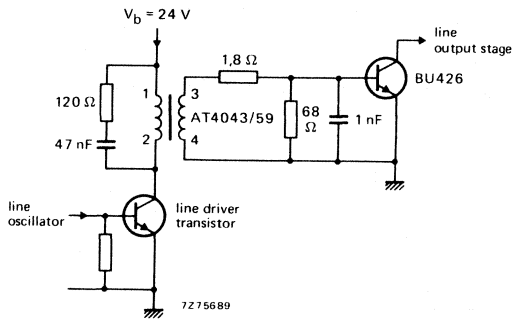

Fig. 4.

E/W INJECTION COIL

- For colour Television

APPLICATION

This injection coil is for the line deflection output stage of the 45AX system.

MECHANICAL DATA

Dimensions in mm

The magnetic circuit of the injection coil comprises two Ferroxcube U15-cores. The coil has four pins for mounting on a printed-wiring board.

Outlines

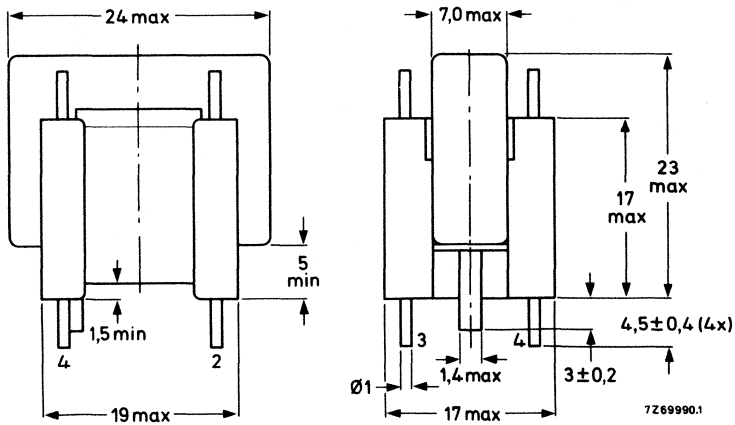

Fig. 1.

Mounting

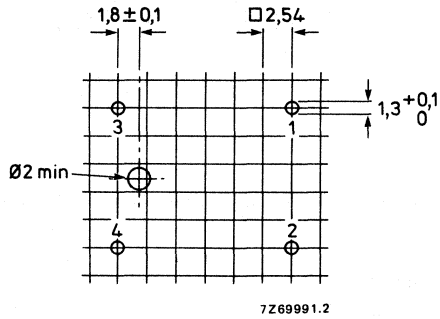

Fig. 2 Hole pattern for mounting on a printed-wiring board (component side).

ELECTRICAL DATA

Inductance *	15 mH ± 12%
Resistance	max. 3 Ω
Maximum current (r.m.s. value)	1,2 A
Maximum working temperature	100 °C

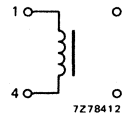

Fig. 3.

* Measuring conditions: E = 3,3 V; f = 1000 Hz.

LINE DRIVER TRANSFORMER

- For Monochrome Data Graphic Displays

APPLICATION

This transformer has been designed for use in monochrome monitors. The required supply voltage is 12 V. The transformer is used in conjunction with deflection unit AT1071/03, line-output transformer AT2102/02, and linearity control unit AT4036/00A.

MECHANICAL DATA

Dimensions in mm

The magnetic circuit of the transformer comprises two Ferroxcube U-cores. The unit is provided with pins for mounting on a printed-wiring board.

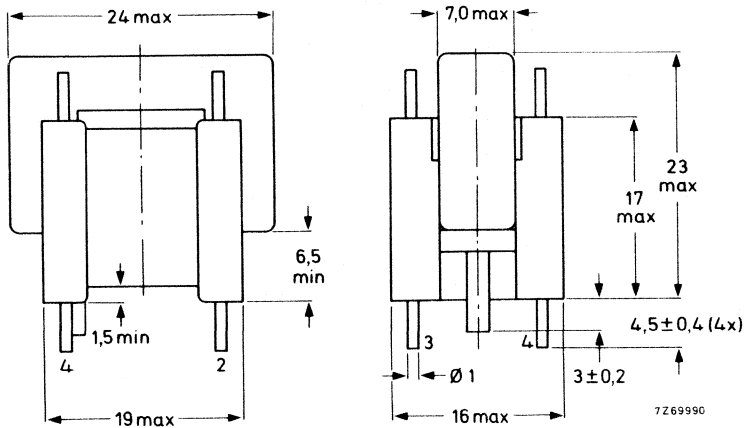

Fig. 1 Line driver transformer AT4043/64.

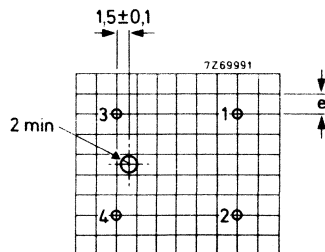

Fig. 2 Hole pattern for mounting on a printed-wiring board (component side). Hole diameter $1,3 \pm 0,1$ mm. $e = 2,54$ mm (0,1 in).

ELECTRICAL DATA

Inductance (primary, 1-2)	1,2 mH
Leakage inductance (secondary)	5 μ H \pm 10%
Transformation ratio	2 : 1
Maximum operating temperature	95 $^{\circ}$ C

Application circuit

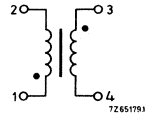

Fig. 3 Circuit diagram.

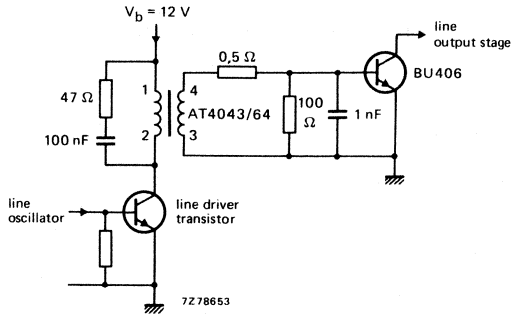

Fig. 4.

DYNAMIC FOCUSING TRANSFORMER

- For Monochrome Data Graphic Displays

APPLICATION

This transformer has been designed to improve the overall picture sharpness of the CRT. It is applied in series with the line coils of the deflection unit to generate a voltage which is fed to the focus electrode.

MECHANICAL DATA

Dimensions in mm

The magnetic circuit of the transformer comprises two Ferroxcube U20-cores, grade 3C8. The primary and secondary windings are wound on a two-part coil former.

The transformer is provided with 6 pins for mounting on a printed-wiring board.

Outlines

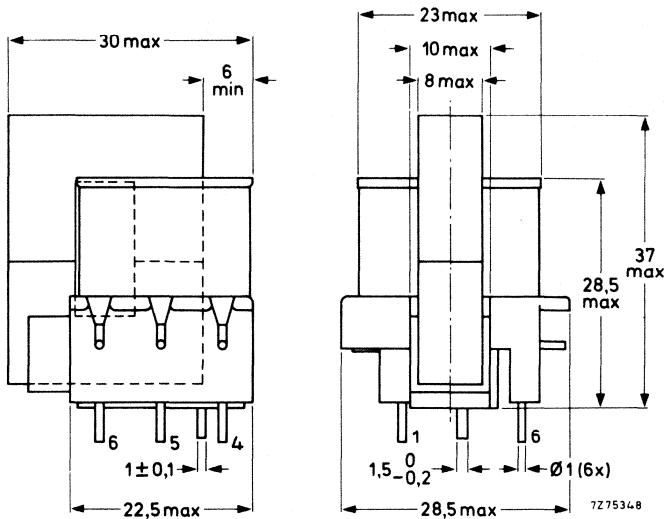
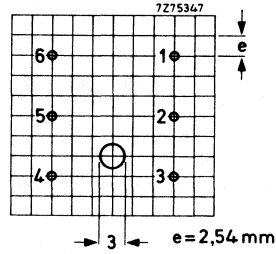

Fig. 1.

Mounting

Fig. 2 Hole pattern for mounting on a printed-wiring board; hole diameter $1,3 \pm 0,1$ mm. Viewed from the component side.



ELECTRICAL DATA

Inductance, secondary (1-3)*	≥ 1 H
Resistance, primary (4-6), at 23 °C	$\leq 0,05 \Omega$
Resistance, secondary (1-3), at 23 °C	$\leq 44 \Omega$
Voltage ratio E_{1-3}/E_{4-6} **	$60,75 \pm 5\%$
Maximum permissible current (r.m.s. value)	
primary (4-6)	3 A
secondary (1-3)	0,125 A
Mains isolation	according to IEC 65
Breakdown voltage	
between winding 1-3 and winding 4-6 or core	≥ 5600 V (d.c.)
between winding 4-6 and core	≥ 500 V (d.c.)
Maximum working temperature	115 °C

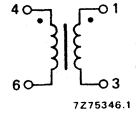

Fig. 3.

Application circuit

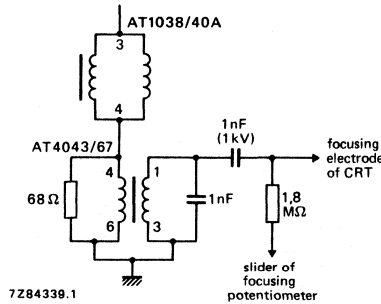

Fig. 4 Application circuit for use with deflection unit AT1038/40A.

* Measuring condition: $E = 20$ V, $f = 1$ kHz.
 ** Measuring condition: $E_{1-3} = 5$ V, $f = 1$ kHz.

TESTS AND REQUIREMENTS

The dynamic focusing transformer withstands the following tests.

IEC 68-2 test method	name of test	procedure (quick reference)
Ua1	Tensile strength of terminations	
Ub (method 1)	Bending of terminations	
Fc	Vibration	Frequency range 10-55-10 Hz, amplitude 0,35 mm, 3 directions, 30 min per direction.
Eb	Bump	1000 bumps in 6 directions, acceleration 25 g.
Ea	Shock	Half-sine pulse shape, 11 ms, 50g, 6 directions, 3 shocks per direction.
Ta (method 1)	Soldering	Solder temp. 230 °C, dwell time 2 s.
Tb (method 1A)	Resistance to soldering heat	
Bb	Dry heat	96 h at + 100 °C.
Db	Damp heat, cyclic	21 cycles of 24 h at + 40 °C, R.H. 95%.
Ab	Cold	96 h at -40 °C.
Ca	Damp heat, steady state	21 days.
Na	Rapid change of temperature	5 cycles of -25 °C/+ 100 °C.
	Flammability	UAN-L1082, class b.

BRIDGE COIL

APPLICATION

The AT4043/68 is designed for the horizontal deflection output stage of 110° and 90° colour deflection systems. It is used in conjunction with the three-layer diode-split line output transformer AT2076/51, AT2076/81 or AT2077/81.

MECHANICAL DATA (Dimensions in mm)

The coil is wound on a combination of two Ferroxcube U15-cores. It has four termination pins for mounting through a printed-wiring board.

Outlines

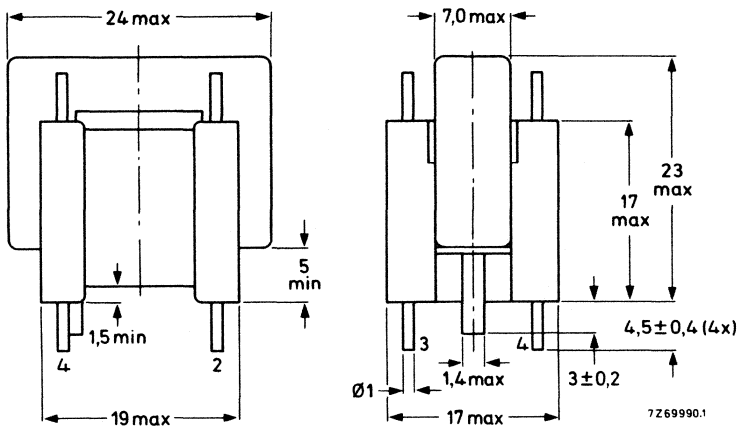

Fig. 1.

Mounting

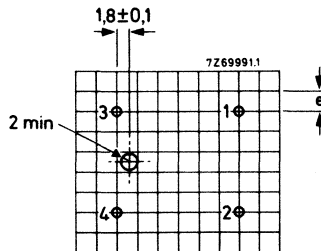

Fig. 2 Hole pattern for mounting on a printed-wiring board (component side). Hole diameter 1,3 ± 0,1 mm. e = 2,54 mm (0,1 in).

ELECTRICAL DATA

Inductance*	0,52 mH \pm 10%
Resistance	max. 0,6 Ω
Maximum peak-to-peak voltage	800 V
Maximum peak-to-peak current	2,9 A
Maximum working temperature	100 °C

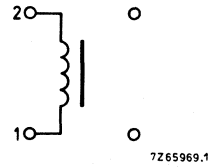

Fig. 3.

* Measuring conditions: E = 0,3 V; f = 1000 Hz.

BRIDGE COIL

- For Colour Data Graphic Displays

APPLICATION

The AT4043/69 is for the horizontal deflection output stage of 90° colour deflection systems. It is used in conjunction with the three-layer diode-split line output transformer AT2076/81 or AT2076/51, driver transformer AT4043/01, shift transformer AT4043/09 and dynamic focusing transformer AT4043/67.

MECHANICAL DATA

The coil is wound on a Ferroxcube I-15 core. It has four termination pins for mounting on a printed-wiring board.

Outlines

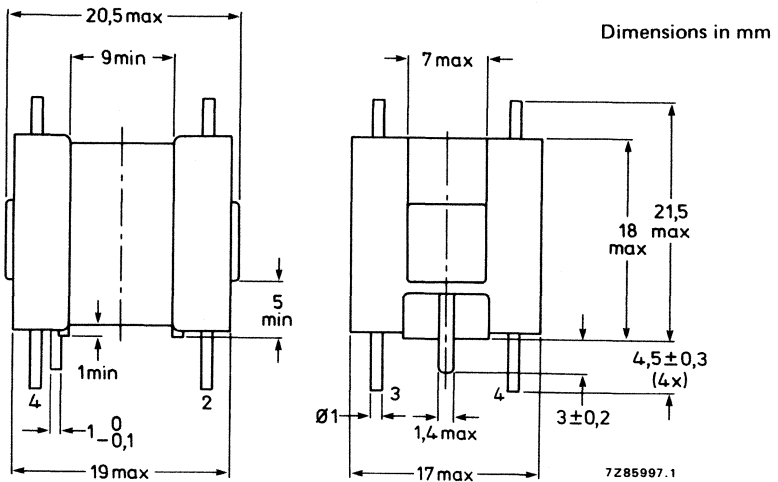

Fig. 1.

Mounting

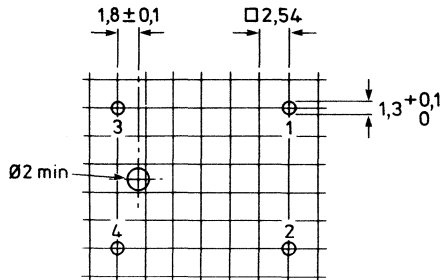
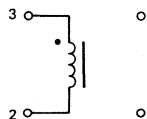

Fig. 2 Hole pattern for mounting on a printed-wiring board (component side).

7269991.2

ELECTRICAL DATA

Inductance *	1,0 mH \pm 10%
Resistance	max. 1,07 Ω
Maximum working temperature	100 °C



7Z90566

Fig. 3.

* Measuring conditions: E = 2,7 V; f = 1000 Hz.

INPUT CHOKE

- For single switch power pack system

APPLICATION

The AT4043/81 is for use as a supply choke in the single switch power pack system (S²P²) for colour TV receivers. It is used in conjunction with mains transformer TS561/2 or TS521B, mains filter choke AT4043/55, current sensing transformer AT4043/46, driver transformer AT4043/82 and diode-split line output transformer AT2076/80.

MECHANICAL DATA

Dimensions in mm

The magnetic circuit comprises two Ferroxcube U25 cores, grade 3C8. The choke has 10 pins ($\phi 1 + 0,1$ mm, length $4,5 \pm 0,5$ mm) for mounting on a printed-wiring board. The maximum height of the choke is 36 mm.

Mounting

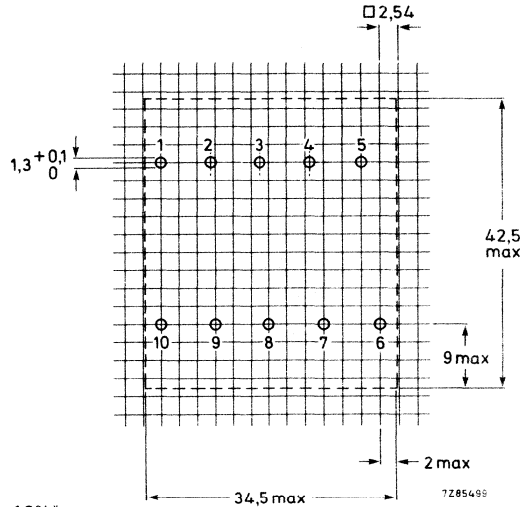

Fig. 1 Hole pattern for mounting on a printed-wiring board, viewed from the solder side.

ELECTRICAL DATA

Inductance (1-7)	25 mH $\pm 10\%$ *
Resistance (1-4)	1,45 $\Omega \pm 10\%$
Resistance (4-7)	1,85 $\Omega \pm 10\%$
Resistance (10-3)	28 $\Omega \pm 10\%$
Maximum peak current (1-7)	0,55 A
Maximum peak current (1-4)	1,1 A
Maximum working temperature	115 °C
Flammability	according to UL94, category V1.

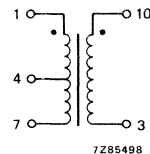

Fig. 2.

* Measuring conditions: E = 20 V, f = 1 kHz.

DRIVER TRANSFORMER

- For single switch power pack system
- Mains insulation

APPLICATION

The AT4043/82 is for use as a transistor driver transformer in the single switch power pack system (S^2P^2) for colour TV receivers. It is used in conjunction with mains transformer TS561/2 or TS521B, mains filter choke AT4043/90, current sensing transformer AT4043/46, input choke AT4043/81 and diode-split line output transformer AT2076/80 or AT2077/80.

MECHANICAL DATA

Dimensions in mm

The magnetic circuit comprises two Ferroxcube U20 cores, grade 3C8. The primary and secondary windings are wound on a two-part coil former with large creepage distances and clearances, which ensure safe insulation between the mains and control circuits. The transformer has six pins for mounting on a printed-wiring board.

Outlines

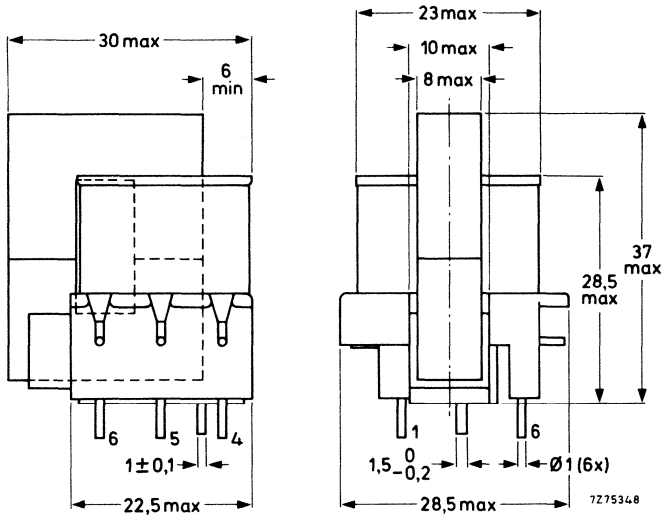
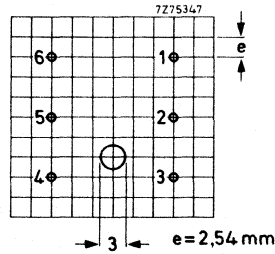

Fig. 1.

Mounting

Fig. 2 Hole pattern for mounting on a printed-wiring board; hole diameter $1,3 \pm 0,1$ mm. Viewed from the component side.



ELECTRICAL DATA

Inductance, primary (4-6)	$\geq 6,8$ mH*
Resistance, primary (4-6), at 25 °C	$2,6 \Omega \pm 10\%$
Leakage inductance, secondary (1-3)	$17 \mu\text{H} \pm 10\%^{**}$
Resistance, secondary (1-3)	$0,11 \Omega \pm 10\%$
Transformation ratio	3,24
Permissible current (r.m.s. value)	
primary (4-6)	200 mA
secondary (1-3)	500 mA
Mains isolation	according to IEC65
Breakdown voltage (d.c.)	
between secondary (1-3) and primary (4-6) or core	≥ 5600 V
between primary (4-6) and core	≥ 500 V
Maximum working temperature	115 °C

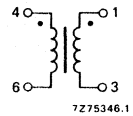

Fig. 3.

* Measuring condition: $E = 3$ V, $f = 1$ kHz.

** Measuring condition (primary short-circuited): $E \leq 250$ mV, 500 kHz $\leq f \leq 600$ kHz.

LINE DRIVER TRANSFORMER

- For Monochrome Data Graphic Displays

APPLICATION

This transformer is for use in monochrome monitors. The required supply voltage is 70 V. The transformer is used in conjunction with deflection unit AT1039/01, line-output transformer AT2076/53 and linearity control unit AT4036/00A.

MECHANICAL DATA

Dimensions in mm

The magnetic circuit of the transformer comprises two Ferroxcube U20-cores. The unit has pins for mounting on a printed-wiring board.

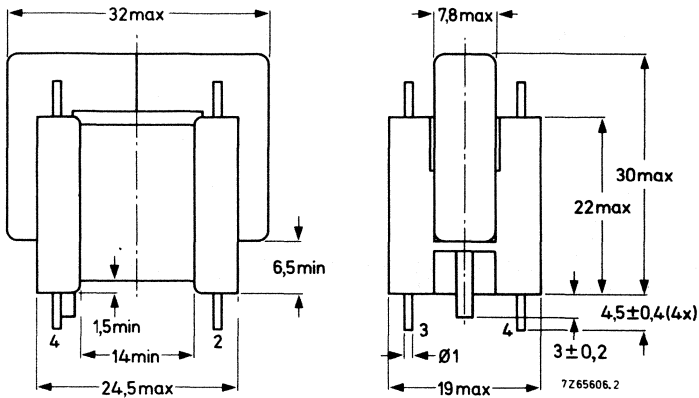

Fig. 1 Line driver transformer AT4043/83.

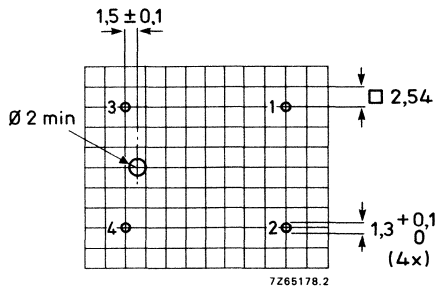
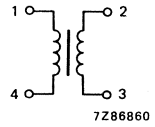

Fig. 2 Hole pattern for mounting on a printed-wiring board (component side). Hole diameter $1,3 + 0,1 / 0$ mm; $e = 2,54$ mm (0,1 in).

ELECTRICAL DATA

Inductance (primary, 1 - 4)	80 mH ± 12%
Leakage inductance (secondary)	6 μH ± 15%
Transformation ratio	12,1 : 1
Maximum operating temperature	95 °C



Application circuit

Fig. 3 Circuit diagram.

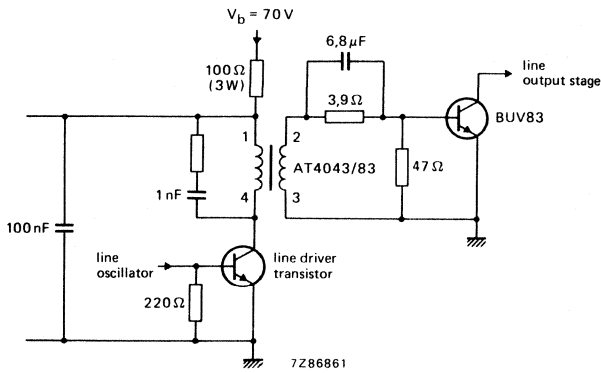

Fig. 4.

Note: Complete description is given in Technical Publication 058: "A full-page data graphic display unit (C62) operating at a line frequency of 32 kHz".

LINE DRIVER TRANSFORMER

APPLICATION

The transformer AT4043/87 has been designed for all-transistor black/white and colour television sets. In black and white television sets it can be used in the single-transistor (BU205) line-output circuit in conjunction with the line-output transformer AT2048/12; in colour television sets it can be used in the single-transistor (BU208A) line-output circuit in conjunction with the line-output transformer AT2076/30.

MECHANICAL DATA

Dimensions in mm

The magnetic circuit of the transformer comprises two Ferroxcube U-cores. The unit is provided with pins for mounting on a printed-wiring board.

Outlines

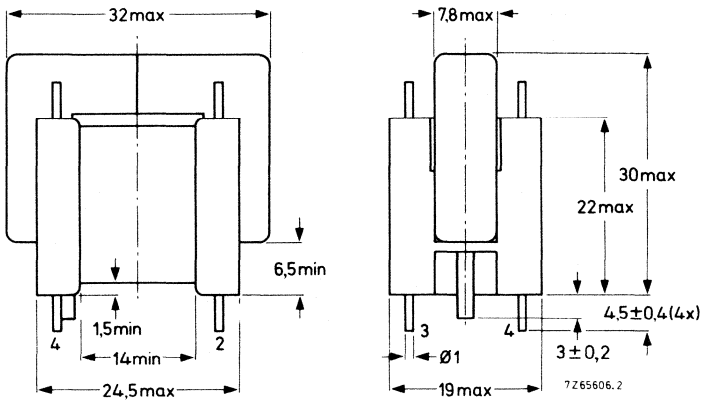

Mounting

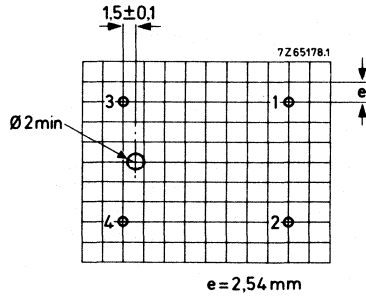

Hole pattern for mounting on a printed-wiring board; hole diameter $1,3 + 0,1$ mm.

ELECTRICAL DATA

Inductance (primary, 1-4)

76 mH \pm 12%

Leakage inductance (secondary)*

$\leq 2,0 \mu\text{H}$

Transformation ratio 4-1/2-3

29 : 1

Maximum working temperature

100 °C

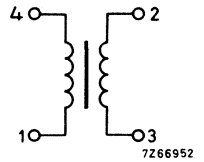

* Primary short circuited.

LINE DRIVER TRANSFORMER

- For colour TV ("Two Chip Design")

APPLICATION

This transformer is for use in economic colour TV receivers with 14 or 16 in 90° picture tubes, in conjunction with line-output transformer AT2078/06 and linearity corrector AT4042/90 or AT4042/91.

MECHANICAL DATA

Dimensions in mm

The magnetic circuit of the transformer comprises two Ferroxcube U10-cores. The unit has pins for mounting on a printed-wiring board.

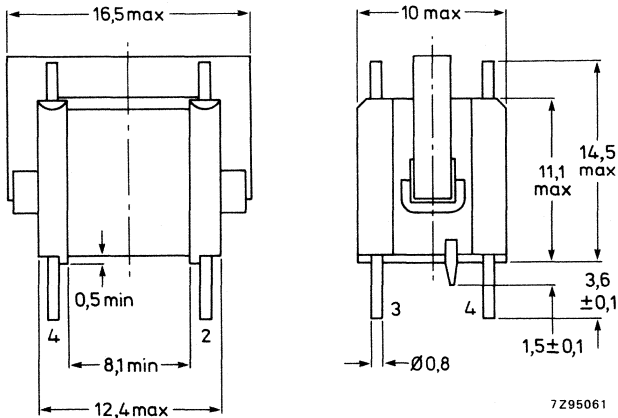

Fig. 1 Line driver transformer AT4043/89.

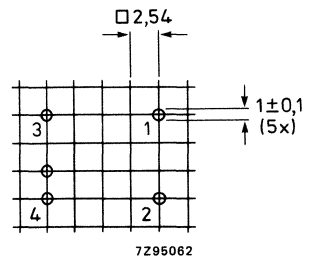

Fig. 2 Hole pattern for mounting on a printed-wiring board (component side).

ELECTRICAL DATA

Inductance (primary, 1 – 2)

3,85 mH ± 15%

Transformation ratio

5: 1

Maximum operating temperature

95 °C

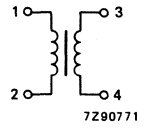

Fig. 3 Circuit diagram.

MAINS FILTER CHOKE FOR 1,0 A rms

APPLICATION

The AT4043/90 is for use in consumer and professional equipment as a part of the filter network in the power supply.

MECHANICAL DATA

The magnetic circuit of the filter choke comprises two Ferroxcube U20 cores. The choke has four pins for mounting on a printed-wiring board.

Outlines

Dimensions in mm

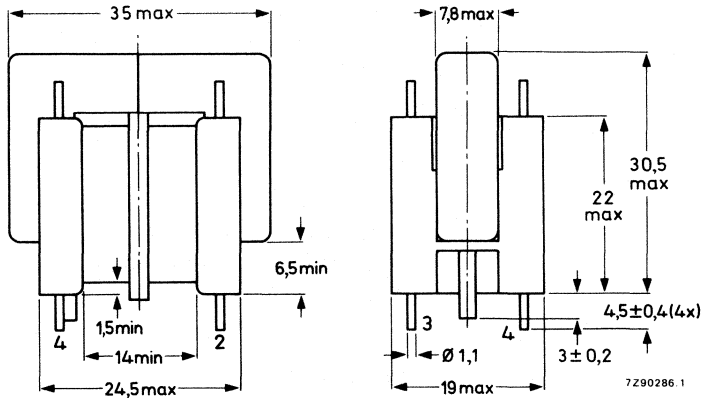
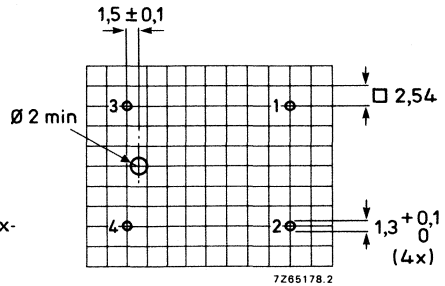

Fig. 1.

Fig. 2 Hole pattern for mounting on a printed-wiring board (component side). The windings may be interchanged because the coil is symmetrical.

Marking

The 12-digit catalogue number is printed on the Ferroxcube cores.



ELECTRICAL DATA

Inductance, $L_{1-2} = L_{3-4}$	$\geq 28 \text{ mH}^*$
Resistance, $R_{1-2} = R_{3-4}$, at 25 °C	1,0 Ω
Leakage inductance	
$L_S(1-2)$, L_{3-4} short-circuited	0,75 mH
$L_S(3-4)$, L_{1-2} short-circuited	0,75 mH
Maximum current (r.m.s.)	1,0 A
Maximum working temperature	115 °C

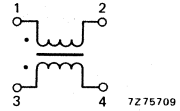

Fig. 3.

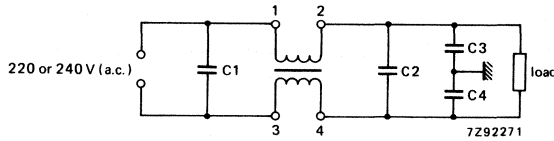

Fig. 4 Application circuit.
 $C1 = C3 = C4 = 3300 \text{ pF}$, 250 V;
 $C2 = 0,47 \text{ }\mu\text{F}$, 250 V.

The choke withstands the following tests:

test	IEC 68 test method	procedure
bump	Eb	1000 bumps, acceleration 245 m/s ² , 6 directions
vibration	Fc	10-55-10 Hz, ampl. 0,35 mm, 3 directions, 30 min/direction
damp heat, steady state	Ca	21 days, 40 °C; 93% R.H.
damp heat, cyclic	Db	21 days, 40 °C
change of temperature	Na	-25 °C, + 100 °C; 5 cycles
dry heat	Bb	96 h, + 100 °C
solderability	Ta	230 ± 10 °C, 2 ± 0,5 s

Reliability

Maximum cumulative percentage catastrophic failures	
after 300 h	$\leq 0,01\%$
after 10 000 h	$\leq 0,02\%$
after 30 000 h	$\leq 1\%$

* Measured at 1 V, 1 kHz.

MAINS FILTER CHOKE FOR 0,25 A rms

APPLICATION

The AT4043/91A is for use in consumer and professional equipment as a part of the filter network in the power supply.

MECHANICAL DATA

The magnetic circuit of the filter choke comprises two Ferroxcube U15 cores. The choke has four pins for mounting on a printed-wiring board.

Outlines

Dimensions in mm

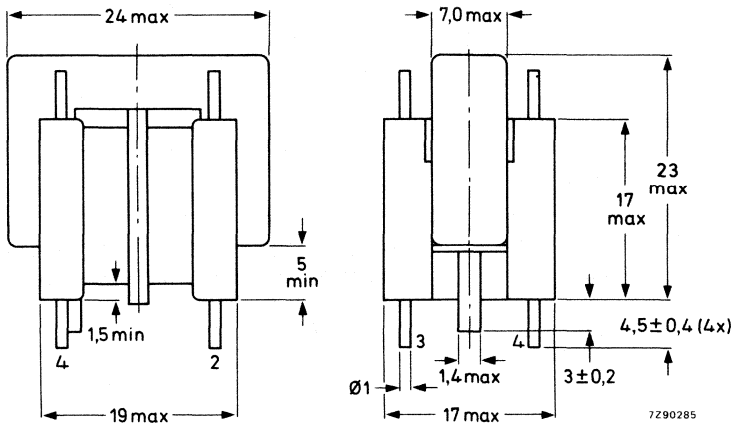
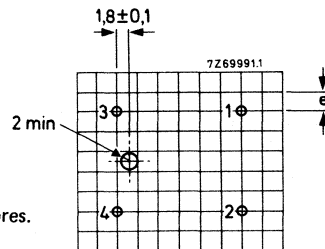

Fig. 1.

Fig. 2 Hole pattern for mounting on a printed-wiring board (component side);
 $e = 2,54$ mm; hole diameter is $1,3 + 0,1$ mm.
 The windings may be interchanged because the coil is symmetrical.

Marking

The 12-digit catalogue number is printed on the Ferroxcube cores.



ELECTRICAL DATA

Inductance, $L_{1-2} = L_{3-4}$	$\geq 40 \text{ mH}^*$
Resistance, $R_{1-2} = R_{3-4}$, at 25 °C	$5,0 \Omega \pm 12\%$
Leakage inductance	
$L_s(1-2)$, L_{3-4} short-circuited	1,5 mH
$L_s(3-4)$, L_{1-2} short-circuited	1,5 mH
Maximum current (r.m.s.)	0,25 A
Maximum working temperature	115 °C

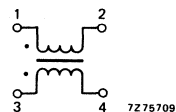

Fig. 3.

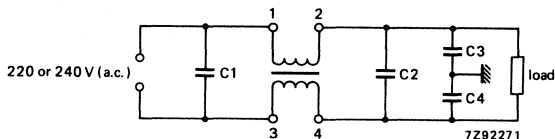

Fig. 4 Application circuit.
 $C1 = C3 = C4 = 3300 \text{ pF}$; 250 V;
 $C2 = 0,47 \mu\text{F}$, 250 V.

The choke withstands the following tests:

test	IEC 68 test method	procedure
bump	Eb	1000 bumps, acceleration 245 m/s^2 , 6 directions
vibration	Fc	10-55-10 Hz, ampl. 0,35 mm, 3 directions, 30 min/direction
damp, heat, steady state	Ca	21 days, 40 °C; 93% R.H.
damp heat, cyclic	Db	21 days, 40 °C
change of temperature	Na	-25 °C, + 100 °C; 5 cycles
dry heat	Bb	96 h, + 100 °C
solderability	Ta	$230 \pm 10 \text{ °C}$; $2 \pm 0,5 \text{ s}$

Reliability

Maximum cumulative percentage catastrophic failures	
after 300 h	$\leq 0,01\%$
after 10 000 h	$\leq 0,02\%$
after 30 000 h	$\leq 1\%$

* Measured at 1 V, 1 kHz.

MAINS FILTER CHOKE FOR 0,5 A rms

APPLICATION

The AT4043/92 is for use in consumer and professional equipment as a part of the filter network in the power supply.

MECHANICAL DATA

The magnetic circuit of the filter choke comprises two Ferroxcube U15 cores. The choke has four pins for mounting on a printed-wiring board.

Outlines

Dimensions in mm

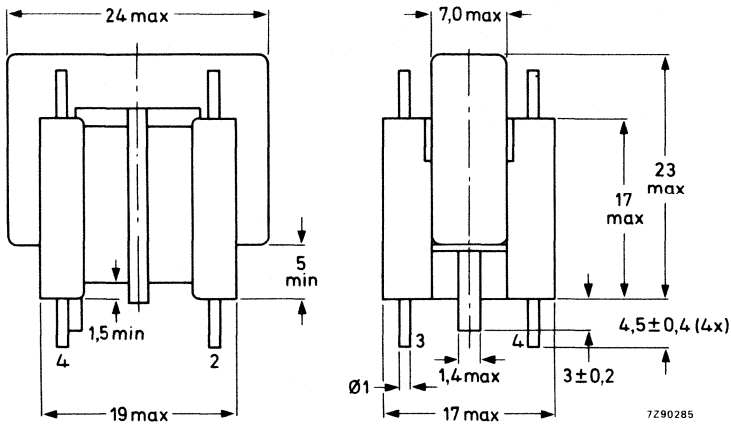
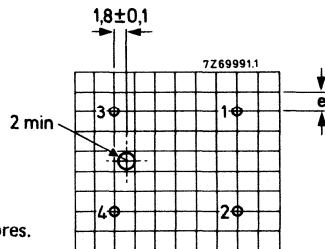

Fig. 1.

Fig. 2 Hole pattern for mounting on a printed-wiring board (component side); $e = 2,54$ mm; hole diameter is $1,3 \pm 0,1$ mm. The windings may be interchanged because the coil is symmetrical.

Marking

The 12-digit catalogue number is printed on the Ferroxcube cores.



ELECTRICAL DATA

Inductance, $L_{1-2} = L_{3-4}$	$\geq 15 \text{ mH}^*$
Resistance, $R_{1-2} = R_{3-4}$, at 25 °C	2,0 Ω
Leakage inductance	
$L_s(1-2)$, L_{3-4} short-circuited	0,7 mH
$L_s(3-4)$, L_{1-2} short-circuited	0,7 mH
Maximum current (r.m.s.)	0,5 A
Maximum working temperature	115 °C

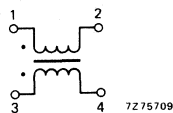

Fig. 3.

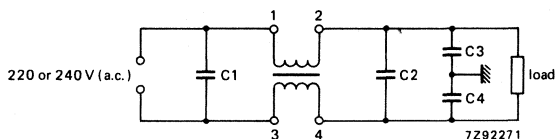

Fig. 4 Application circuit.

$C1 = C3 = C4 = 3300 \text{ pF}$, 250 V;
 $C2 = 0,47 \text{ }\mu\text{F}$, 250 V.

The choke withstands the following tests:

test	IEC 68 test method	procedure
bump	Eb	1000 bumps, acceleration 245 m/s ² , 6 directions
vibration	Fc	10-55-10 Hz, ampl. 0,35 mm, 3 directions, 30 min/direction
damp heat, steady state	Ca	21 days, 40 °C; 93% R.H.
damp heat, cyclic	Db	21 days, 40 °C
change of temperature	Na	-25 °C, + 100 °C; 5 cycles
dry heat	Bb	96 h, + 100 °C
solderability	Ta	230 \pm 10 °C, 2 \pm 0,5 s

Reliability

Maximum cumulative percentage catastrophic failures	
after 300 h	$\leq 0,01\%$
after 10 000 h	$\leq 0,02\%$
after 30 000 h	$\leq 1\%$

* Measured at 1,6 V, 1 kHz.

MAINS FILTER CHOKE FOR 1,5 A rms

APPLICATION

The AT4043/93 is for use in consumer and professional equipment as a part of the filter network in the power supply.

MECHANICAL DATA

The magnetic circuit of the filter choke comprises two Ferroxcube U20 cores. The choke has four pins for mounting on a printed-wiring board.

Outlines

Dimensions in mm

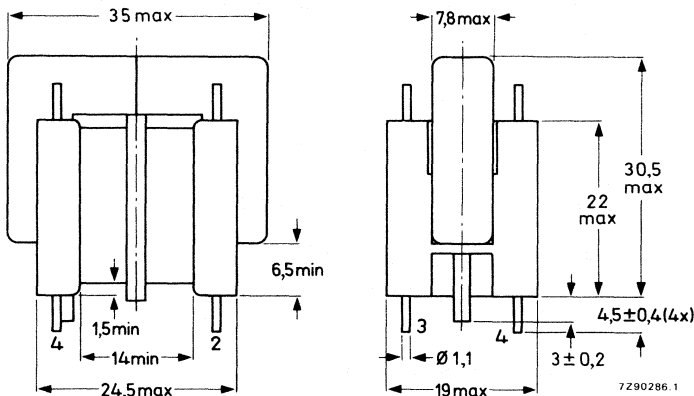
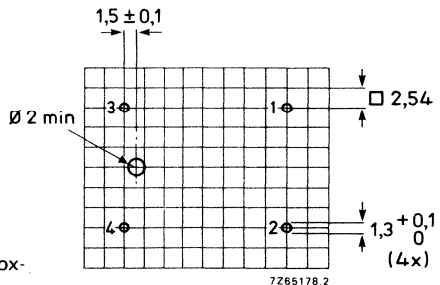

Fig. 1.

Fig. 2 Hole pattern for mounting on a printed-wiring board (component side). The windings may be interchangeable because the coil is symmetrical.



Marking

The 12-digit catalogue number is printed on the Ferroxcube cores.

ELECTRICAL DATA

Inductance, $L_{1-2} = L_{3-4}$	$\geq 12 \text{ mH}^*$
Resistance, $R_{1-2} = R_{3-4}$, at 25 °C	$0,4 \Omega \pm 10\%$
Leakage inductance	
$L_s(1-2)$, L_{3-4} short-circuited	0,5 mH
$L_s(3-4)$, L_{1-2} short-circuited	0,5 mH
Maximum current (r.m.s.)	1,5 A
Test voltage (d.c.) between the windings, and between windings and core	2000 V
Maximum working temperature	115 °C

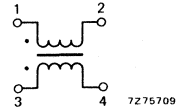

Fig. 3.

The choke withstands the following tests:

test	IEC 68 test method	procedure
bump	Eb	1000 bumps, acceleration 245 m/s^2 , 6 directions
vibration	Fc	10-55-10 Hz, ampl. 0,35 mm, 3 directions, 30 min/direction
damp heat, steady state	Ca	21 days, 40 °C, 93% R.H.
damp heat, cyclic	Db	21 days, 40 °C
change of temperature	Na	-25 °C, + 100 °C; 5 cycles
dry heat	Bb	96 h, + 100 °C
solderability	Ta	$230 \pm 10 \text{ °C}$, $2 \pm 0,5 \text{ s}$

Reliability

Maximum cumulative percentage catastrophic failures	
after 300 h	$\leq 0,01\%$
after 10 000 h	$\leq 0,02\%$
after 30 000 h	$\leq 1\%$

* Measured at 2,2 V, 1 kHz.

BRIDGE COIL

APPLICATION

This bridge coil is for the line deflection output stage of the 45AX system.

MECHANICAL DATA

Dimensions in mm

The magnetic circuit comprises two Ferroxcube U20 cores, grade 3C8. The transformer has four connecting pins and a location pin for mounting on a printed-wiring board.

Outlines

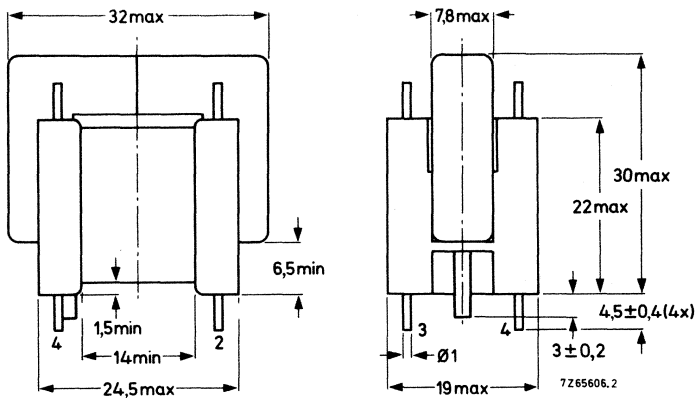

Fig. 1.

Mounting

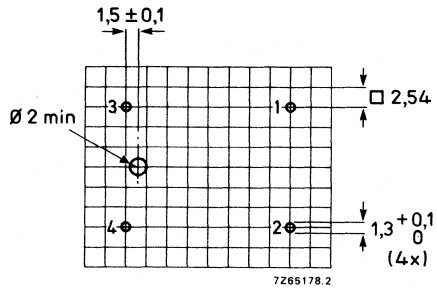

Fig. 2 Hole pattern for mounting on a printed-wiring board (component side).

ELECTRICAL DATA

Inductance (1-4)	1 mH \pm 12%
Resistance (1-4) at 25 °C	0,125 Ω \pm 12%
Maximum permissible peak current	1,3 A
Maximum working temperature	100 °C

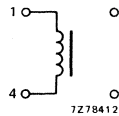

Fig. 3.

SWITCHED-MODE TRANSFORMER

- For consumer applications, e.g. record players, cassette recorders, television sets.

DESCRIPTION

The magnetic circuit of the transformer comprises two Ferroxcube E12,6-cores. The transformer has 4 pins for mounting on a printed-wiring board.

MECHANICAL DATA

Dimensions in mm

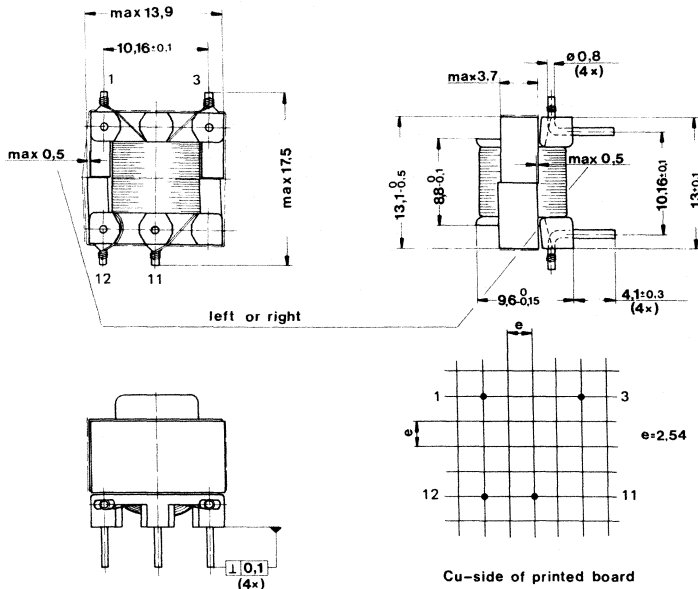

8109

ELECTRICAL DATA

 catalogue number 3112 338 30910

Inductance, primary*	(1-12) 3,3 mH ± 10%
Leakage inductance, primary	(1-6) 10%
Maximum current, primary	(1-6) 320 mA
Number of turns	
primary	(1-12) = 228
secondary	(11-3) = 16

Test voltage (d.c.) between primary and secondary 500 V

Approbation

Sets with transformers of this construction are released by Demko, Nemko, Semko, EI, SEV, UL and BSI.

TESTS

The transformer withstands the following tests:

Vibration	IEC 68-2-6, test Fc; 10-55-10 Hz, amplitude 0,35 mm 3 x 30 min
Bump	IEC 68-2-29, test Eb; 25g, 4000 bumps, 6 directions
Dry heat	IEC 68-2-2, test Bb; 96 h, +125 °C
Damp heat, steady state	IEC 68-2-3, test Ca; 21 days, R.H. 95%
Damp heat, accelerated	IEC 68-2-4, test Db; +40 °C, R.H. 95 to 100%
Rapid change of temperature	IEC 68-2-14, test Na; 5 cycles, T _A = -25 °C, T _B = +100 °C

* Measured at 10 kHz, B_{max} = 0,3 T.

SWITCHED-MODE TRANSFORMER

- For consumer applications, e.g. record players, cassette recorders, television sets

DESCRIPTION

The magnetic circuit of the transformer comprises two Ferroxcube E12,6 cores. The transformer has 5 pins for mounting on a printed-wiring board.

MECHANICAL DATA

Dimensions in mm

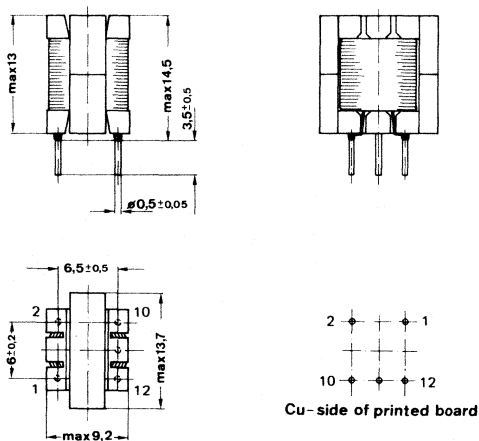

8099

ELECTRICAL DATA

catalogue number 3112 338 30440

Inductance, primary (1-2)*	3 mH \pm 10%
Leakage inductance, primary (1-2)	0,2%
Maximum current, primary (1-2)	300 mA
Number of turns	
primary (1-2)	220
secondary (10-12)	22
Test voltage (d.c.)	
between primary and secondary	1500 V
between primary and core	1500 V

Approbation

Sets with transformers of this construction are released by Demko, Nemko, Semko, EI, SEV, UL and BSI.

TESTS

The transformer withstands the following tests:

Vibration	IEC 68-2-6, tests Fc; 10-55-10 Hz, amplitude 0,35 mm 3 x 30 min
Bump	IEC 68-2-29, test Eb; 25g, 4000 bumps, 6 directions
Dry heat	IEC 68-2-2, test Bb; 96 h, + 125 °C
Damp heat, steady state	IEC 68-2-3, test Ca; 21 days, R.H. 95%
Damp heat, accelerated	IEC 68-2-4, test Db; + 40 °C, R.H. 95 to 100%
Rapid change of temperature	IEC 68-2-14, test Na; 5 cycles, $T_A = -25$ °C, $T_B = + 100$ °C

* Measured at 10 kHz, $B_{max} = 0,3$ T.

SWITCHED-MODE TRANSFORMER

- For consumer applications, e.g. record players, cassette recorders, television sets.

DESCRIPTION

The magnetic circuit of the transformer comprises two Ferroxcube E12,6-cores. The transformer has 4 pins for mounting on a printed-wiring board.

MECHANICAL DATA

Dimensions in mm

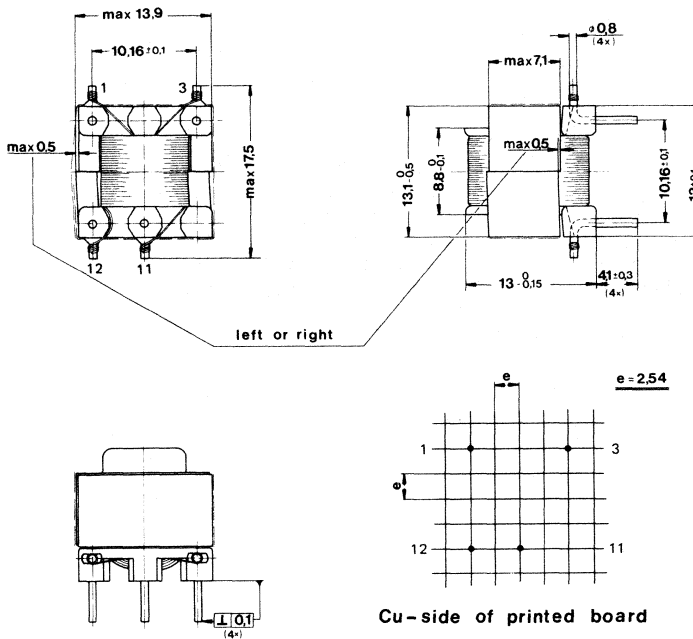

8110

ELECTRICAL DATA

	catalogue number 3112 338 30800
Inductance, primary*	(1-12) 5,6 mH \pm 10%
Leakage inductance, primary	(1-12) 5,4%
Maximum current, primary	(1-12) 325 mA
Number of turns	
primary	(1-12) = 252
secondary	(11-3) = 14

Test voltage (d.c.)	
between primary and secondary	1500 V
between primary and core	1500 V

Approbation

Sets with transformers of this construction are released by Demko, Nemko, Semko, EI, SEV, UL and BSI.

TESTS

The transformer withstands the following tests:

Vibration	IEC 68-2-6, test Fc; 10-55-10 Hz, amplitude 0,35 mm 3 x 30 min
Bump	IEC 68-2-29, test Eb; 25g, 4000 bumps, 6 directions
Dry heat	IEC 68-2-2, test Bb; 96 h, +125 °C
Damp heat, steady state	IEC 68-2-3, test Ca; 21 days, R.H. 95%
Damp heat, accelerated	IEC 68-2-4, test Db; +40 °C, R.H. 95 to 100%
Rapid change of temperature	IEC 68-2-14, test Na; 5 cycles, T _A = -25 °C, T _B = +100 °C

* Measured at 10 kHz, B_{max} = 0,3 T.

SWITCHED-MODE TRANSFORMER

- For consumer applications, e.g. video recorders, television sets, monitors.

DESCRIPTION

The magnetic circuit of the transformer comprises two Ferroxcube E42/15 cores. The coil is built-up in layers of copper wire, separated from each other by insulation foils. A screen between primary and secondary guarantees the required insulation between the windings. The transformer has 22 pins for mounting on a printed-wiring board.

MECHANICAL DATA

Dimensions in mm

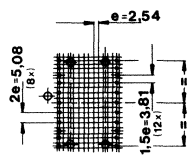
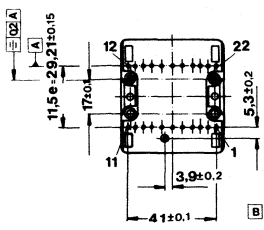
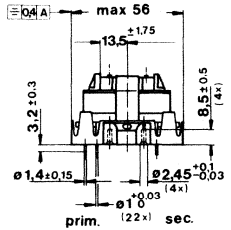
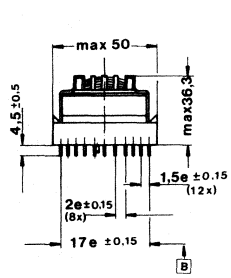

Cu-side of printed board

8107

ELECTRICAL DATA

	catalogue number		
	3112	338 31070	3112 338 31150 **
Inductance, primary*	(7-5) 0,94 mH \pm 10%	(5-7) 0,67 mH \pm 10%	
Leakage inductance, primary	(7-5) 2,1%	(5-7) 2,1%	
Maximum current, primary	(7-5) 2,03 A	(5-7) 2,5 A	
Number of turns primary	(2-1) = 4 (4-3) = 1 (7-5) = 34	(2-1) = 5 (4-3) = 1 (7-5) = 32	
secondary	(20-19) = 6 (21-22) = 3 (16-18) = 5 (15-14) = 7 (13-12) = 14	(20-19) = 6 (21-22) = 4 (16-18) = 7 (15-14) = 16 (13-12) = 4	

Diagram

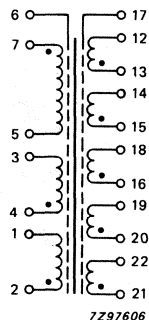

Test voltage (d.c.)

between primary and secondary
between primary and core

5600 V

5600 V

Mains insulation

according to IEC 65 class 2,
VDE0860 and UL1411

Maximum operating temperature

115 °C

Approbation

Sets with transformers of this construction are released by Demko, Nemko, Semko, EI, SEV, UL and BSI.

TESTS

The transformer withstands the following tests:

Vibration	IEC 68-2-6, test Fc; 10-55-10 Hz, amplitude 0,35 mm 3 x 30 min
Bump	IEC 68-2-29, test Eb; 25g, 4000 bumps, 6 directions
Dry heat	IEC 68-2-2, test Bb; 96 h, +125 °C
Damp heat, steady state	IEC 68-2-3, test Ca; 21 days, R.H. 95%
Damp heat, accelerated	IEC 68-2-4, test Db; +40 °C, R.H. 95 to 100%
Rapid change of temperature	IEC 68-2-14, test Na; 5 cycles, T _A = -25 °C, T _B = +55 °C

* Measured at 10 kHz, B_{max} = 0,3 T.

** UL approved.

SWITCHED-MODE TRANSFORMER

- For consumer applications, e.g. television sets, monitors

DESCRIPTION

The magnetic circuit of the transformer comprises two Ferroxcube E42/15 cores. The coil is built-up in layers of copper wire, separated from each other by insulation foils. The transformer has 14 pins for mounting on a printed-wiring board.

MECHANICAL DATA

Dimensions in mm

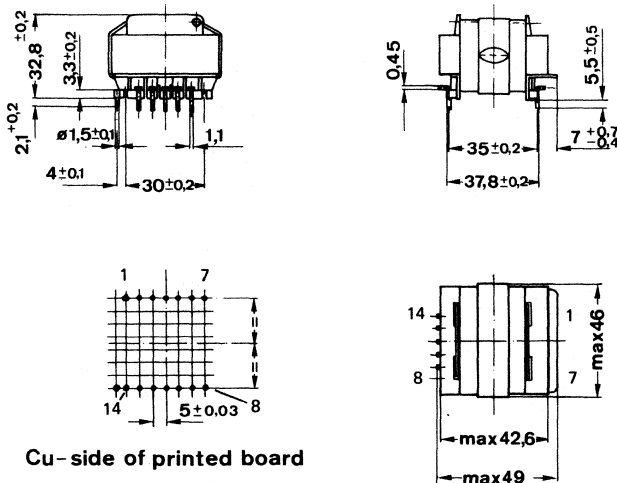

Cu-side of printed board

8098

ELECTRICAL DATA

	catalogue number					
	3112	338	30550	3112	338	30970
Inductance, primary*	(5-4) 2,5 mH ± 10%			(3-2) 1,9 mH ± 10%		
Leakage inductance, primary	(5-4) 1,2%			(3-2) 2%		
Maximum current, primary	(5-4) 1,2 A			(3-2) 1,36 A		
Number of turns primary	(5-4) = 78 (2-3) = 2 (3-7) = 2			(3-2) = 64 (4-6) = 2 (6-5) = 1		
secondary	(5-6) = 39 (13-9) = 34 (12-13) = 33 (11-10) = 8			(9-10) = 52 (11-12) = 11 (13-10) = 7		
Diagram				<p style="text-align: right; font-size: small;">7297605</p>		
Test voltage (d.c.) between primary and secondary	5600 V					
between primary and core	5600 V					
Mains insulation	according to IEC 65 class 2, and VDE0860					
Maximum operating temperature	115 °C					

Approbation

Sets with transformers of this construction are released by Demko, Nemko, Semko, EI, SEV, UL and BSI.

TESTS

The transformer withstands the following tests:

Vibration	IEC 68-2-6, test Fc; 10-55-10 Hz, amplitude 0,35 mm 3 x 30 min
Bump	IEC 68-2-29, test Eb; 25g, 4000 bumps, 6 directions
Dry heat	IEC 68-2-2, test Bb; 96 h, + 125 °C
Damp heat, steady state	IEC 68-2-3, test Ca; 21 days, R.H. 95%
Damp heat, accelerated	IEC 68-2-4, test Db; + 40 °C, R.H. 95 to 100%
Rapid change of temperature	IEC 68-2-14, test Na; 5 cycles, T _A = -25 °C, T _B = + 85 °C

* Measured at 10 kHz, B_{max} = 0,3 T.

SWITCHED-MODE TRANSFORMER

- For consumer applications, e.g. television sets, monitors.

DESCRIPTION

The magnetic circuit of the transformer comprises two Ferroxcube E42/15 cores. The coil is built-up in layers of copper wire, separated from each other by insulation foils. The transformer has 18 pins for mounting on a printed-wiring board.

MECHANICAL DATA

Dimensions in mm

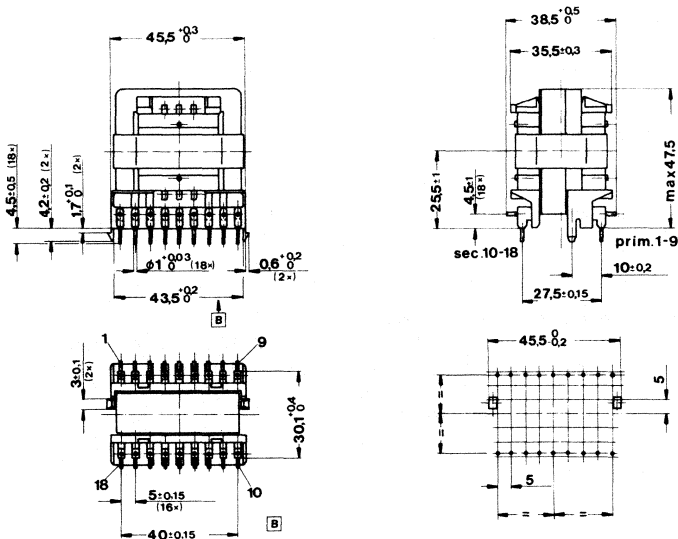

8119

Cu-side of printed board

ELECTRICAL DATA

catalogue number 3112 338 30940

Inductance, primary*	(4-6) 1,8 mH ± 10%
Leakage inductance, primary	(4-6) 1,4%
Maximum current, primary	(4-6) 1,7 A
Number of turns primary	(1-2) = 1 (8-9) = 1 (3-7) = 3 (4-6) = 50
secondary	(13-15) = 19 (11-10) = 13 (16-12) = 4 (18-17) = 3

Test voltage (d.c.) between primary and secondary	5600 V
between primary and core	5600 V
Mains insulation	according to IEC 65 class 2, and VDE0860
Maximum operating temperature	115°C

Approbation

Sets with transformers of this construction are released by Demko, Nemko, Semko, EI, SEV, UL and BSI.

TESTS

The transformer withstands the following tests:

Vibration	IEC 68-2-6, test Fc; 10-55-10 Hz, amplitude 0,35 mm 3 x 30 min
Bump	IEC 68-2-29, test Eb; 25g, 4000 bumps, 6 directions
Dry heat	IEC 68-2-2, test Bb; 96 h, +125 °C
Damp heat, steady state	IEC 68-2-3, test Ca; 21 days, R.H. 95%
Damp heat, accelerated	IEC 68-2-4, test Db; +40 °C, R.H. 95 to 100%
Rapid change of temperature	IEC 68-2-14, test Na; 5 cycles, T _A = -25 °C, T _B = +55 °C

* Measured at 10 kHz, B_{max} = 0,3 T.

SWITCHED-MODE TRANSFORMER

- For consumer applications, e.g. television sets, monitors.

DESCRIPTION

The magnetic circuit of the transformer comprises two Ferroxcube E42/20 cores. The coil is built-up in layers of copper wire, separated from each other by insulation foils. A screen between primary and secondary guarantees the required insulation between the windings. The transformer has 22 pins for mounting on a printed-wiring board.

MECHANICAL DATA

Dimensions in mm

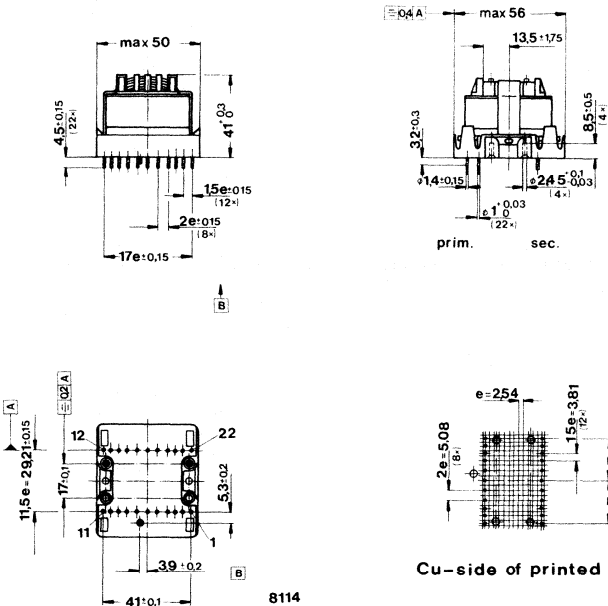

ELECTRICAL DATA

	catalogue number	
	3112 338 30620	3112 338 31040
Inductance, primary*	(5-7) 1,5 mH ± 10%	(7-5) 0,4 mH ± 10%
Leakage inductance, primary	(5-7) 2%	(7-5) 3,75%
Maximum current, primary	(5-7) 2,9 A	
Number of turns primary	(1-2) = 1 (8-9) = 1 (10-11) = 4 (5-7) = 51	(2-1) = 2 (9-8) = 2 (11-10) = 2 (7-5) = 31
secondary	(18-16) = 25 (12-13) = 10 (15-14) = 3	(18-16) = 45 (20-19) = 11 (22-21) = 9 (14-15) = 9 (12-13) = 5
Test voltage (d.c.) between primary and secondary between primary and core		5600 V 5600 V
Mains insulation		according to IEC 65 class 2, and VDE0860
Maximum operating temperature		115 °C

Approbation

Sets with transformers of this construction are released by Demko, Nemko, Semko, EI, SEV, UL and BSI.

TESTS

The transformer withstands the following tests:

Vibration	IEC 68-2-6, test Fc; 10-55-10 Hz, amplitude 0,35 mm 3 x 30 min
Bump	IEC 68-2-29, test Eb; 25g, 4000 bumps, 6 directions
Dry heat	IEC 68-2-2, test Bb; 96 h, +125 °C
Damp heat, steady state	IEC 68-2-3, test Ca; 21 days, R.H. 95%
Damp heat, accelerated	IEC 68-2-4, test Db; +40 °C, R.H. 95 to 100%
Rapid change of temperature	IEC 68-2-14, test Na; 5 cycles, T _A = -25 °C, T _B = +55 °C

* Measured at 10 kHz, B_{max} = 0,3 T.

SWITCHED-MODE TRANSFORMER

- For consumer applications, e.g. television sets, monitors.

DESCRIPTION

The magnetic circuit of the transformer comprises two Ferroxcube E42/20 cores. The coil is built-up in layers of copper wire, separated from each other by insulation foils. A screen between primary and secondary guarantee the required insulation between the windings. The transformer has 22 pins for mounting on a printed-wiring board.

MECHANICAL DATA

Dimensions in mm

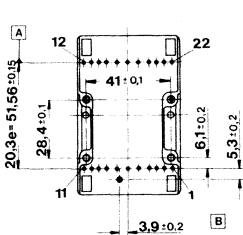
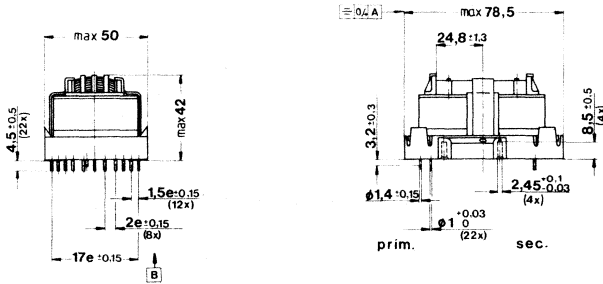

8115

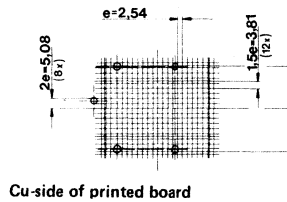

Cu-side of printed board

ELECTRICAL DATA

	catalogue number 3112 338 30740
Inductance, primary*	(5-7) 1,35 mH \pm 10%
Leakage inductance, primary	(5-7) 1,5%
Maximum current, primary	(5-7) 3,55 A
Number of turns primary	(1-2) = 2 (8-9) = 1 (10-11) = 5 (5-7) = 68
secondary	(18-16) = 37 (12-13) = 15 (15-14) = 4 (19-20) = 6 (21-22) = 6
Test voltage (d.c.) between primary and secondary	5600 V
between primary and core	5600 V
Mains insulation	according to IEC 65 class 2, and VDE0860
Maximum operating temperature	115 °C

Approbation

Sets with transformers of this construction are released by Demko, Nemko, Semko, EI, SEV, UL and BSI.

TESTS

The transformer withstands the following tests:

Vibration	IEC 68-2-6, test Fc; 10-55-10 Hz, amplitude 0,35 mm 3 x 30 min
Bump	IEC 68-2-29, test Eb; 25g, 4000 bumps, 6 directions
Dry heat	IEC 68-2-2, test Bb; 96 h, +125 °C
Damp heat, steady state	IEC 68-2-3, test Ca; 21 days, R.H. 95%
Damp heat, accelerated	IEC 68-2-4, test Db; +40 °C, R.H. 95 to 100%
Rapid change of temperature	IEC 68-2-14, test Na; 5 cycles, T _A = -25 °C, T _B = +35 °C

* Measured at 10 kHz, B_{max} = 0,3 T.

BRIDGE COIL

- For consumer applications, e.g. record players, cassette recorders, television sets, monitors

DESCRIPTION

The coil is wound on a Ferroxcube I-10 core. It has four termination pins for mounting on a printed-wiring board.

MECHANICAL DATA

Dimensions in mm

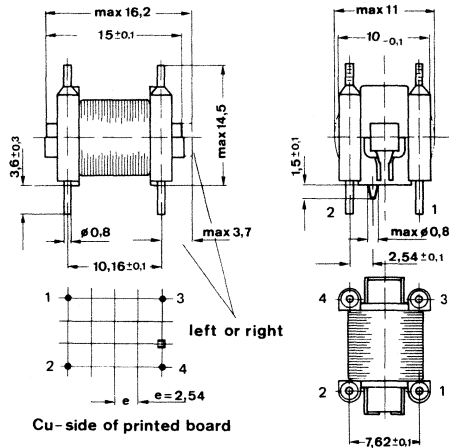

ELECTRICAL DATA

		catalogue number				
		3122 138 71330	3122 138 74310	3122 138 74290	3112 338 30790	3112 338 30460
Inductance*	(1-4) 0,14 mH	(1-4) 0,2 mH	(1-2) 0,05 mH	(1-2) 0,03 mH	(3-1) 0,38 mH	
Resistance**	(1-4) 0,29 Ω	(1-4) 0,37 Ω	(1-2) 0,17 Ω	(1-2) 0,056 Ω	(3-1) 0,68 Ω	

Approbation

Sets with coils of this construction are released by Demko, Nemko, Semko, EI, SEV, UL and BSI.

TESTS

The bridge coil withstands the following tests:

Vibration	IEC 68-2-6, test Fc; 10-55-10 Hz, amplitude 0,35 mm 3 x 30 min
Bump	IEC 68-2-29, test Eb; 25g, 4000 bumps, 6 directions
Dry heat	IEC 68-2-2, test Bb; 96 h, + 125 °C
Damp heat, steady state	IEC 68-2-3, test Ca; 21 days, R.H. 95%
Damp heat, accelerated	IEC 68-2-4, test Db; + 40 °C, R.H. 95 to 100%
Rapid change of temperature	IEC 68-2-14, test Na; 5 cycles, T _A = -25 °C, T _B = + 100 °C

* Tol. \pm 10%; measured at 1 kHz, B_{max} = 0,3 T.

** Tol. \pm 12%; measured at T_{amb} = 23 °C.

PULSE TRANSFORMER

- For use in switched mode power supplies
- For consumer applications, e.g. record players, cassette recorders, television sets.

DESCRIPTION

The coil is wound on a Ferroxcube I-10 core. It has four termination pins for mounting on a printed-wiring board.

The coil former has three sections, of which the middle section is a safety distance between the other two.

MECHANICAL DATA

Dimensions in mm

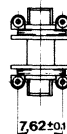
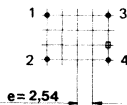
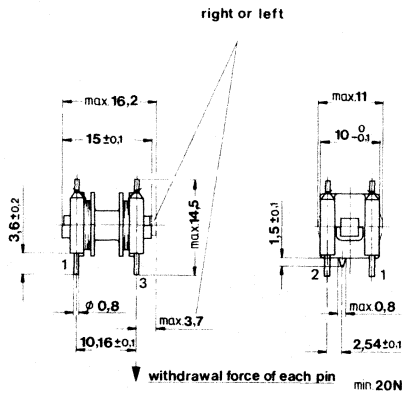

Cu - side of printed board

8112

ELECTRICAL DATA

	catalogue number	
	3112 338 31010	3112 338 31190
Resistance, primary	(1-2) 18 Ω	(1-2) 20,5 Ω
secondary	(3-4) 18 Ω	(3-4) 3,5 Ω
Maximum current, primary	(1-2) 610 mA	(1-2) 690 mA
Turns ratio	200 : 200	225 : 45

Diagram

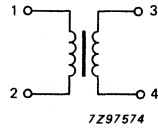

Insulation resistance between primary and secondary	> 60 MΩ
Test voltage (d.c.) between primary and secondary	5600 V
Mains insulation	according to IEC 65 class 2, and VDE0860

Approbation

Sets with transformers of this construction are released by Demko, Nemko, Semko, EI, SEV, UL and BSI.

TESTS

The transformer withstands the following tests:

Vibration	IEC 68-2-6, test Fc; 10-55-10 Hz, amplitude 0,35 mm 3 x 30 min
Bump	IEC 68-2-29, test Eb; 25g, 4000 bumps, 6 directions
Dry heat	IEC 68-2-2, test Bb; 96 h, +125 °C
Damp heat, steady state	IEC 68-2-3, test Ca; 21 days, R.H. 95%
Damp heat, accelerated	IEC 68-2-4, test Db; +40 °C, R.H. 95 to 100%
Rapid change of temperature	IEC 68-2-14, test Na; 5 cycles, T _A = -25 °C, T _B = +100 °C

BRIDGE COIL

- For consumer applications, e.g. record players, cassette recorders, television sets

DESCRIPTION

The coil is wound on a Ferroxcube I-15 core. It has four termination pins for mounting on a printed-wiring board.

MECHANICAL DATA

Dimensions in mm

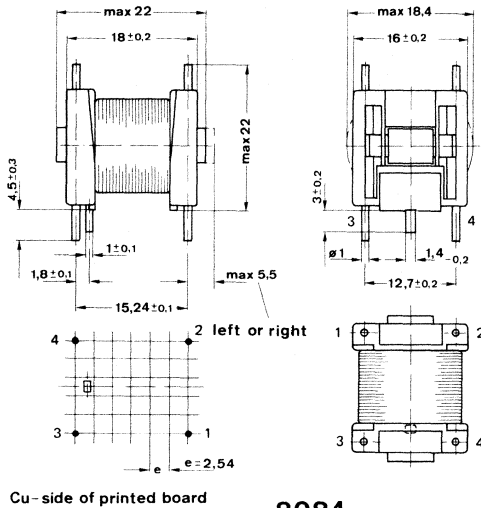

8084

ELECTRICAL DATA

	catalogue number				
	3122 138 71800	3122 138 29390	3122 138 29360	3112 338 30650	3112 338 30200▲
Inductance* (2-3) 1,0 mH	(1-3) 0,18 mH	(1-4) 0,14 mH	(3-4) 0,43 mH	(3-4) 0,2 mH	
Resistance** (2-3) 1,07 Ω	(1-3) 0,3 Ω	(1-4) 0,23 Ω	(3-4) 0,48 Ω	(3-4) 0,3 Ω	

Approval

Sets with coils of this construction are released by Demko, Nemko, Semko, EI, SEV, UL and BSI.

TESTS

The bridge coil withstands the following tests:

Vibration	IEC 68-2-6, test Fc; 10-55-10 Hz, amplitude 0,35 mm 3 x 30 min
Bump	IEC 68-2-29, test Eb; 25 g, 4000 bumps, 6 directions
Dry heat	IEC 68-2-2, test Bb; 96 h, + 125 °C
Damp heat, steady state	IEC 68-2-3, test Ca; 21 days, R.H. 95%
Damp heat, accelerated	IEC 68-2-4, test Db; + 40 °C, R.H. 95 to 100%
Rapid change of temperature	IEC 68-2-14, test Na; 5 cycles, T _A = -25 °C, T _B = + 100 °C

* Tol. ± 10%; measured at 1 kHz, B_{max} = 0,3 T.

** Tol. ± 12%; measured at T_{amb} = 23 °C.

▲ UL approved.

BRIDGE COIL

- For consumer applications, e.g. record players, cassette recorders, television sets.

DESCRIPTION

The coil is wound on a Ferroxcube I-20 core. It has four termination pins for mounting on a printed-wiring board.

MECHANICAL DATA

Dimensions in mm

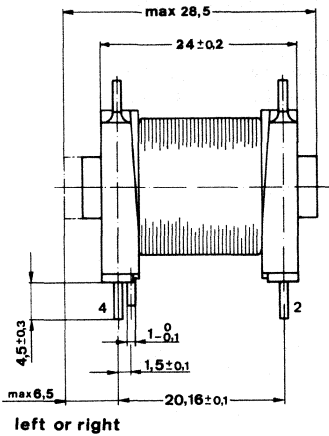

left or right

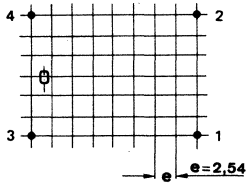

Cu - side of printed board

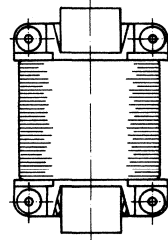
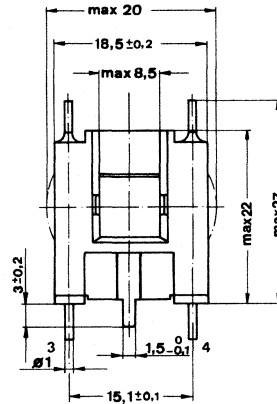

8094

ELECTRICAL DATA

	catalogue number		
	3112 338 30920	3122 138 94810	3122 138 28870
Inductance*	(1-2) 1,05 mH	(1-2) 0,43 mH	(1-2) 0,35 mH
Resistance**	(1-2) 1,17 Ω	(1-2) 0,55 Ω	(1-2) 0,21 Ω
Maximum current	(1-2) 3 A		

Approbation

Sets with coils of this construction are released by Demko, Nemko, Semko, EI, SEV, UL and BSI.

TESTS

The bridge coil withstands the following tests:

Vibration	IEC 68-2-6, test Fc; 10-55-10 Hz, amplitude 0,35 mm 3 x 30 min
Bump	IEC 68-2-29, test Eb; 25g, 4000 bumps, 6 directions
Dry heat	IEC 68-2-2, test Bb; 96 h, +125 °C
Damp heat, steady state	IEC 68-2-3, test Ca; 21 days, R.H. 95%
Damp heat, accelerated	IEC 68-2-4, test Db; +40 °C, R.H. 95 to 100%
Rapid change of temperature	IEC 68-2-14, test Na; 5 cycles, T _A = -25 °C, T _B = +100 °C

* Tol. \pm 10%; measured at 1 kHz, B_{max} = 0,3 T.

** Tol. \pm 12%; measured at T_{amb} = 23 °C.

LINE DRIVER TRANSFORMERS, BRIDGE COILS AND CHOKES

- For consumer applications, e.g. television sets, monitors, video recorders

DESCRIPTION

The magnetic circuit of the unit comprises two Ferroxcube U10 cores. The unit has four pins for mounting on a printed-wiring board.

MECHANICAL DATA

Dimensions in mm

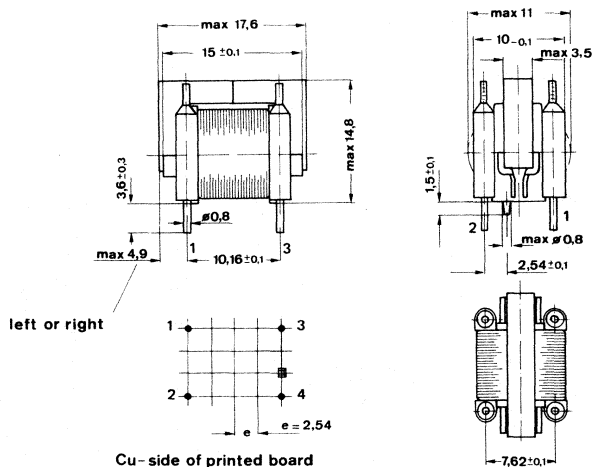

8092

ELECTRICAL DATA

	catalogue number					
	3112 338 30070	3112 338 30390	3112 338 30880	3112 338 31030	3112 338 31090	3122 138 90070
Inductance* ($\pm 10\%$)	(3-4) 0,9 mH	(1-2) 0,1 mH	(1-2) 85 mH	(3-4) 2,5 mH	(1-2) 20 mH	(1-2) 3,85 mH
Resistance** ($\pm 12\%$)	(3-4) 0,85 Ω	(1-2) 0,2 Ω (3-4) 0,03 Ω	(1-2) 39 Ω (3-4) 0,8 Ω	(1-2) 0,53 Ω (3-4) 1,05 Ω (3-4) 2,4%	(1-2) 1,02 Ω (3-4) 0,49 Ω	(1-2) 2,0 Ω (3-4) 0,6 Ω
Leakage inductance						
Maximum current	(3-4) 385 mA	(1-2) 1200 mA	(1-2) 29 mA	(3-4) 1500 mA	(1-2) 36 mA	
Transformation ratio		45 : 7	1000 : 50	135 : 99	194 : 66	200 : 40
Diagram						

Approbation

Sets with units of this construction are released by Demko, Nemko, Semko, Ei, SEV, UL and BSI.

TESTS

The unit withstands the following tests:

- Vibration IEC 68-2-6, test Fc; 10-55-10 Hz, amplitude 0,35 mm
- Bump IEC 68-2-29, test Eb; 25g, 4000 bumps, 6 directions
- Dry heat IEC 68-2-2, test Bb; 96 h, +125 $^{\circ}\text{C}$
- Damp heat, steady state IEC 68-2-3, test Ca; 21 days, R.H. 95%
- Damp heat, accelerated IEC 68-2-4, test Db; +40 $^{\circ}\text{C}$, R.H. 95 to 100%
- Rapid change of temperature IEC 68-2-14, test Na; 5 cycles, $T_A = -25^{\circ}\text{C}$
 $T_B = +100^{\circ}\text{C}$

* Measured at 1 kHz, $B_{\text{max}} = 0,1 \text{ T}$.

** Measured at $T_{\text{amb}} = 23^{\circ}\text{C}$.

FILTER COIL

- For applications where a low winding capacitance and a small stray field are required, e.g. car radios, video recorders.

DESCRIPTION

The magnetic circuit consists of a Ferroxcube U11 core. The winding is split up over two coil formers, each of which is mounted on a leg of the core.

MECHANICAL DATA

Dimensions in mm

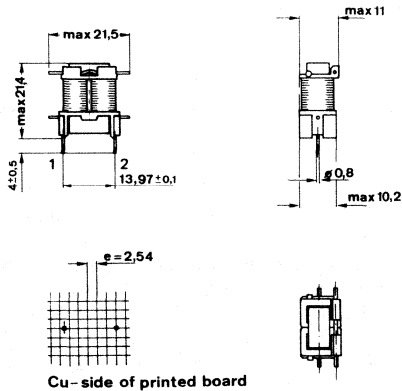

8097

ELECTRICAL DATA

Inductance*
 Resistance**
 Maximum current
 Diagram

catalogue number	
3122 138 51020	3122 138 99460
(1-2) 0,75 mH ± 10%	(1-2) 0,185 mH ± 10%
(1-2) 0,45 Ω ± 12%	(1-2) 0,11 Ω ± 12%
530 mA	2500 mA

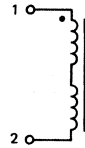

7297568

Approbation

Sets with coils of this construction are released by Demko, Nemko, Semko, EI, SEV, UL and BSI.

TESTS

The coil withstands the following tests:

- Vibration IEC 68-2-6, test Fc; 10-55-10 Hz, amplitude 0,35 mm
3 x 30 min
- Bump IEC 68-2-29, test Eb; 25g, 4000 bumps, 6 directions
- Dry heat IEC 68-2-2, test Bb; 96 h, +125 °C
- Damp heat, steady state IEC 68-2-3, test Ca; 21 days, R.H. 95%
- Damp heat, accelerated IEC 68-2-4, test Db; +40 °C, R.H. 95 to 100%
- Rapid change of temperature IEC 68-2-14, test Na; 5 cycles, T_A = -25 °C,
T_B = +100 °C

* Measured at 1 kHz, B_{max} = 0,1 T.
 ** Measured at T_{amb} = 23 °C.

LINE DRIVER TRANSFORMERS, BRIDGE COILS AND CHOKES

- For consumer applications, e.g. television sets, monitors

DESCRIPTION

The magnetic circuit of the unit comprises two Ferroxcube U15 cores. The unit has four pins for mounting on a printed-wiring board.

MECHANICAL DATA

Dimensions in mm

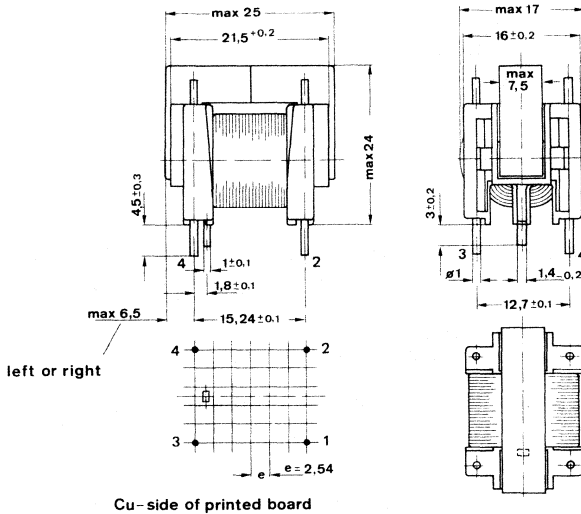

8081

ELECTRICAL DATA

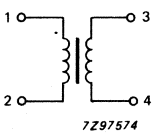
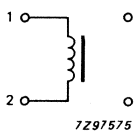
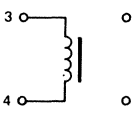
	catalogue number			
	3122 138 93520	3122 138 93870	3122 138 96550	3112 338 31120
	driver transformer	E/W injection coil	bridge coil	choke
Inductance* ($\pm 10\%$)	(1-2) 6,1 mH	(1-2) 15 mH	(1-2) 0,52 mH	(3-4) 8 mH
Resistance** ($\pm 12\%$)	(1-2) 2,3 Ω (3-4) 0,22 Ω	(1-2) 2,6 Ω	(1-2) 0,6 Ω	(3-4) 1,7 Ω
Leakage inductance	(1-2) < 13,8 μ H			
Maximum current		(1-2) 1200 mA	(1-2) 1850 mA	(3-4) 300 mA
Transformation ratio	180 : 43			
Diagram				

Approbation

Sets with units of this construction are released by Demko, Nemko, Semko, EI, SEV, UL and BSI.

TESTS

The unit withstands the following tests:

Vibration	IEC 68-2-6, test Fc; 10-55-10 Hz, amplitude 0,35 mm 3 x 30 min
Bump	IEC 68-2-29, test Eb; 25g, 4000 bumps, 6 directions
Dry heat	IEC 68-2-2, test Bb; 96 h, +125 $^{\circ}$ C
Damp heat, steady state	IEC 68-2-3, test Ca; 21 days, R.H. 95%
Damp heat, accelerated	IEC 68-2-4, test Db; +40 $^{\circ}$ C, R.H. 95 to 100%
Rapid change of temperature	IEC 68-2-14, test Na; 5 cycles, $T_A = -25$ $^{\circ}$ C, $T_B = +100$ $^{\circ}$ C.

* Measured at 1 kHz, $B_{max} = 0,1$ T.

** Measured at $T_{amb} = 23$ $^{\circ}$ C

catalogue number				
3112 338 30980	3122 138 95450	3112 338 30840	3112 338 30820	3112 338 30420
driver transformer	driver transformer	driver transformer	driver transformer	driver transformer
(1-2) 8,5 mH	(1-2) 1,2 mH	(1-2) 12,8 mH	(1-2) 470 mH	(1-2) 1000 mH
(1-2) 2,8 Ω	(1-2) 0,55 Ω	(1-2) 9 Ω	(1-2) 320 Ω	(1-2) 105 Ω
(3-4) 0,16 Ω	(3-4) 0,3 Ω	(3-4) 0,14 Ω	(3-4) 0,28 Ω	(3-4) 1,65 Ω
	(3-4) < 6 μ H	(3-4) < 9 μ H	(3-4) < 8,4 μ H	(3-4) < 25 μ H
(1-2) 200 mA		(1-2) 220 mA	(1-2) 35 mA	(1-2) 15 mA
186 : 27	100 : 50	300 : 43	1750 : 51	1600 : 63

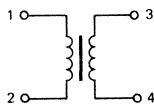

7Z97574

FILTER COIL

- For applications where a low winding capacitance and a small stray field are required, e.g. record players, cassette recorders, car radios.

DESCRIPTION

The magnetic circuit consists of a Ferroxcube U15 core. The winding is split up over two coil formers, each of which is mounted on a leg of the core. The transformer has 4 pins for mounting on a printed-wiring board.

MECHANICAL DATA

Dimensions in mm

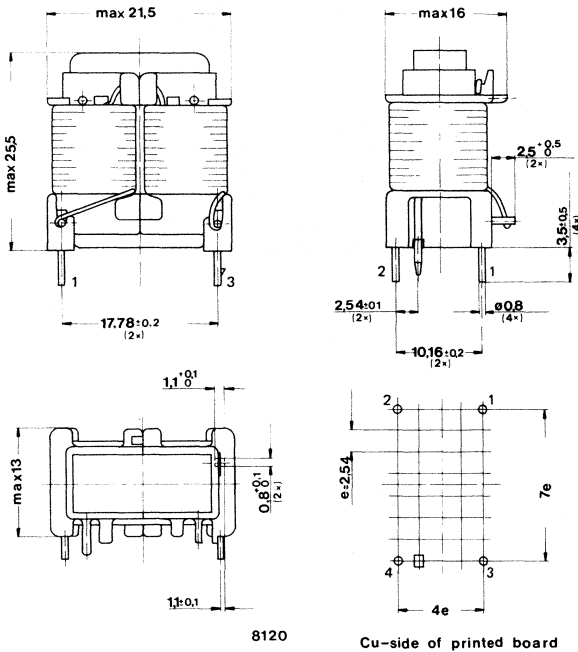

ELECTRICAL DATA

catalogue number 3112 338 30720

Inductance (1-3)*	0,16 mH ± 10%
Resistance (1-3)**	0,055 Ω ± 12%
Maximum current (1-3)	5000 mA

Diagram



Approbation

Sets with coils of this construction are released by Demko, Nemko, Semko, EI, SEV, UL and BSI.

TESTS

The coil withstands the following tests:

Vibration	IEC 68-2-6, test Fc; 10-55-10 Hz, amplitude 0,35 mm 3 x 30 min
Bump	IEC 68-2-29, test Eb; 25g, 4000 bumps, 6 directions
Dry heat	IEC 68-2-2, test Bb; 96 h, +125 °C
Damp heat, steady state	IEC 68-2-3, test Ca; 21 days, R.H. 95%
Damp heat, accelerated	IEC 68-2-4, test Db; +40 °C, R.H. 95 to 100%
Rapid change of temperature	IEC 68-2-14, test Na; 5 cycles, T _A = -25 °C, T _B = +100 °C

* Measured at 1 kHz, B_{max} = 0,1 T.
** Measured at T_{amb} = 23 °C.

MAINS FILTER CHOKE

- For filter networks in the power supply
- For consumer applications, e.g. television sets, monitors, compact disc players.

DESCRIPTION

The magnetic circuit of the filter choke comprises two Ferroxcube U15 cores. The choke has four pins for mounting on a printed-wiring board.

MECHANICAL DATA

Dimensions in mm

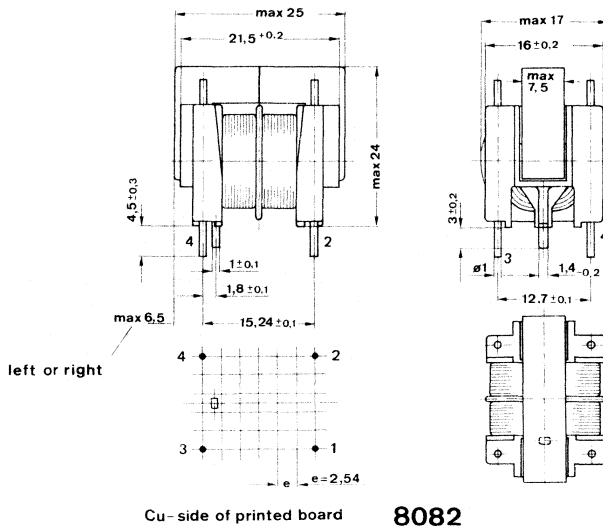

ELECTRICAL DATA

	catalogue number			
	3122 138 52560	3112 338 30640	3112 338 30170	3112 338 31020
Inductance* ($\pm 10\%$) $L_{1-2} = L_{3-4}$	0,7 mH	70 mH	25 mH	0,7 mH
Resistance** ($\pm 12\%$) $R_{1-2} = R_{3-4}$	2,0 Ω	5,0 Ω	1,9 Ω	0,08 Ω
Maximum current, I_{1-2}	500 mA	250 mA	480 mA	290 mA

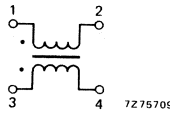

Diagram.

Test voltage (d.c.)	
between windings	2000 V
between windings and core	2000 V

Approbation

Sets with chokes of this construction are released by Demko, Nemko, Semko, EI, SEV, UL and BSI.

TESTS

The choke withstands the following tests:

Vibration	IEC 68-2-6, test Fc; 10-55-10 Hz, amplitude 0,35 mm 3 x 30 min
Bump	IEC 68-2-29, test Eb; 25g, 4000 bumps, 6 directions
Dry heat	IEC 68-2-2, test Bb; 96 h, + 125 °C
Damp heat, steady state	IEC 68-2-3, test Ca; 21 days, R.H. 95%
Damp heat, accelerated	IEC 68-2-4, test Db; + 40 °C, R.H. 95 to 100%
Rapid change of temperature	IEC 68-2-14, test Na; 5 cycles, $T_A = -25$ °C, $T_B = + 100$ °C

* Measured at 1 kHz, $B_{max} = 0,1$ T.

** Measured at $T_{amb} = 23$ °C.

LINE DRIVER TRANSFORMERS, BRIDGE COILS AND CHOKES

- For consumer applications, e.g. record players, cassette recorders, television sets

DESCRIPTION

The magnetic circuit of the unit comprises two Ferroxcube U20 cores. The unit has four pins for mounting on a printed-wiring board.

MECHANICAL DATA

Dimensions in mm

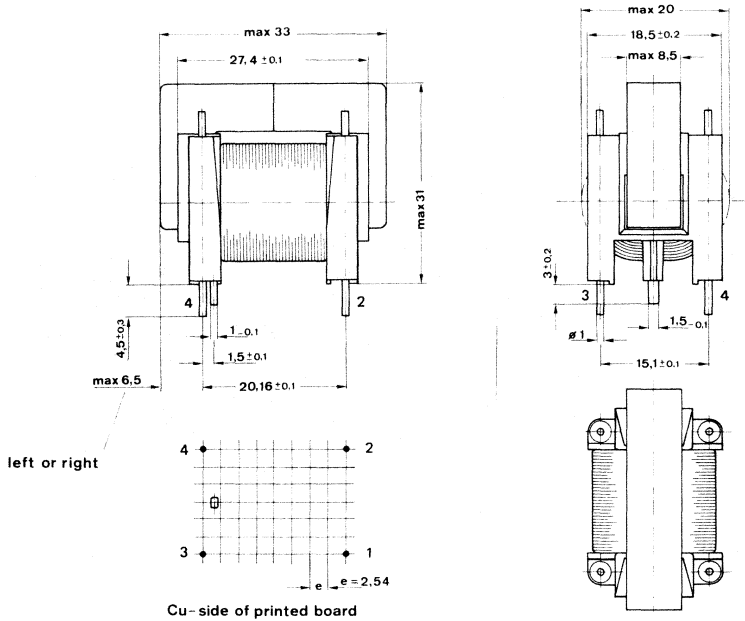

8089

ELECTRICAL DATA

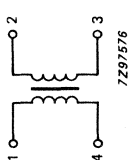
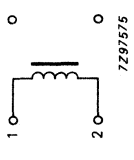
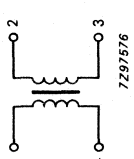
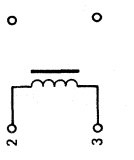
		catalogue number			
		3112 338 30830	3112 338 31000	3112 338 30380	3112 338 30210
Inductance* ($\pm 10\%$)	driver transformer	bridge coil	bridge coil	driver transformer	choke
Resistance** ($\pm 12\%$)	(1-4) 80 mH (1-4) 42 Ω (2-3) 0,64 Ω	(1-4) 1 mH (1-4) 0,14 Ω	(1-2) 0,05 mH (1-2) 0,04 Ω	(1-4) 0,3 mH (1-4) 0,17 Ω (2-3) 0,01 Ω	(2-3) 20 mH (2-3) 13,5 Ω
Leakage inductance	(2-3) < 6,9 μ H	(1-4) 1,3 mA	(1-2) 5000 mA	(1-4) 3400 mA	(2-3) 400 mA
Maximum current	(1-4) 95 mA				
Transformation ratio	184 : 40			62 : 3	
Diagram					

Approbation

Sets with units of this construction are released by Demko, Nemko, Semko, EI, SEV, UL and BSI.

TESTS

- The unit withstands the following tests:
- Vibration IEC 68-2-6, test Fc; 10-55-10 Hz, amplitude 0,35 mm
 - 3 x 30 min
 - Bump IEC 68-2-29, test Eb; 25g, 4000 bumps, 6 directions
 - Dry heat IEC 68-2-2, test Bb; 96 h, +125 $^{\circ}$ C
 - Damp heat, steady state IEC 68-2-3, test Ca; 21 days, R.H. 95%
 - Damp heat, accelerated IEC 68-2-4, test Db; +40 $^{\circ}$ C, R.H. 95 to 100%
 - Rapid change of temperature IEC 68-2-14, test Na; 5 cycles, $T_A = -25$ $^{\circ}$ C, $T_B = +100$ $^{\circ}$ C.

* Measured at 1 kHz, $B_{max} = 0,1$ T.

** Measured at $T_{amb} = 23$ $^{\circ}$ C.

DRIVER TRANSFORMER

- For consumer applications, e.g. television sets, monitors

DESCRIPTION

The magnetic circuit of the transformer comprises two Ferroxcube U20 cores. The primary and secondary windings are on separate coil formers, and concentrically mounted on one leg of the core. The transformer has six pins for mounting on a printed-wiring board.

MECHANICAL DATA

Dimensions in mm

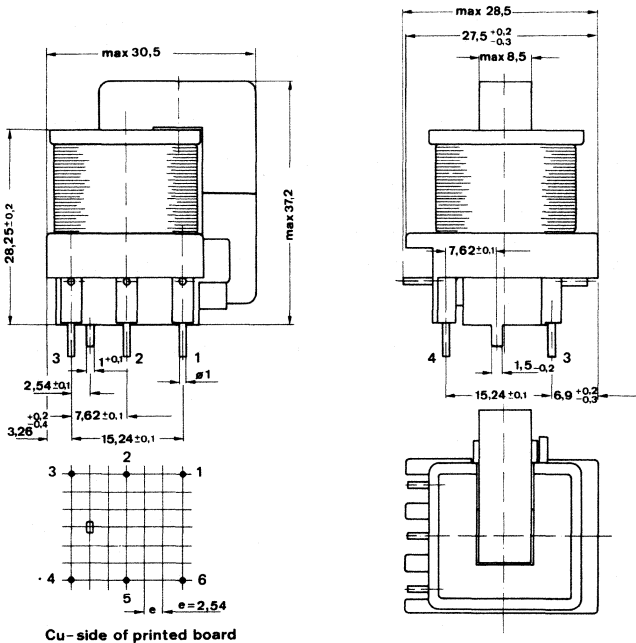

8090

ELECTRICAL DATA

	catalogue number			
	3122 138 96570	3122 138 90290	3122 138 90580	3112 338 30780
Inductance * primary	(1-3) > 1 mH	(4-6) > 16 mH	(4-6) > 6 mH	(1-2) 5 mH
Leakage inductance primary			(4-6) 1%	(1-2) 1%
Number of turns primary	(1-3) = 800	(4-6) = 100	(4-6) = 60	(1-2) = 200 (2-3) = 20
secondary	(4-6) = 13	(1-3) = 20	(1-3) = 20	(4-5) = 15 (5-6) = 4
Diagram				

7297570

Test voltage (d.c.)	
between (1-2-3) and (4-5-6)	5600 V
between (1-2-3) and core	5600 V
between (4-5-6) and core	500 V

Mains insulation according to IEC 65 class 2, VDE 0860

Approbation

Sets with transformers of this construction are released by Demko, Nemko, Semko, EI, SEV, UL and BSI.

TESTS

The transformer withstands the following tests:

Vibration	IEC 68-2-6, test Fc; 10-55-10 Hz, amplitude 0,35 mm 3 x 30 min
Bump	IEC 68-2-29, test Eb; 25g, 4000 bumps, 6 directions
Dry heat	IEC 68-2-2, test Bb; 96 h, +125 °C
Damp heat, steady state	IEC 68-2-3, test Ca; 21 days, R.H. 95%
Damp heat, accelerated	IEC 68-2-4, test Db; +40 °C, R.H. 95 to 100%
Rapid change of temperature	IEC 68-2-14, test Na; 5 cycles, T _A = -25 °C, T _B = +100 °C

* Measured at 1 kHz, B_{max} = 0,1 T.

MAINS FILTER CHOKE

- For filter networks in the power supply
- For consumer applications, e.g. record players, cassette recorders, television sets

DESCRIPTION

The magnetic circuit of the filter choke comprises two Ferroxcube U20 cores. The choke has four pins for mounting on a printed-wiring board.

MECHANICAL DATA

Dimensions in mm

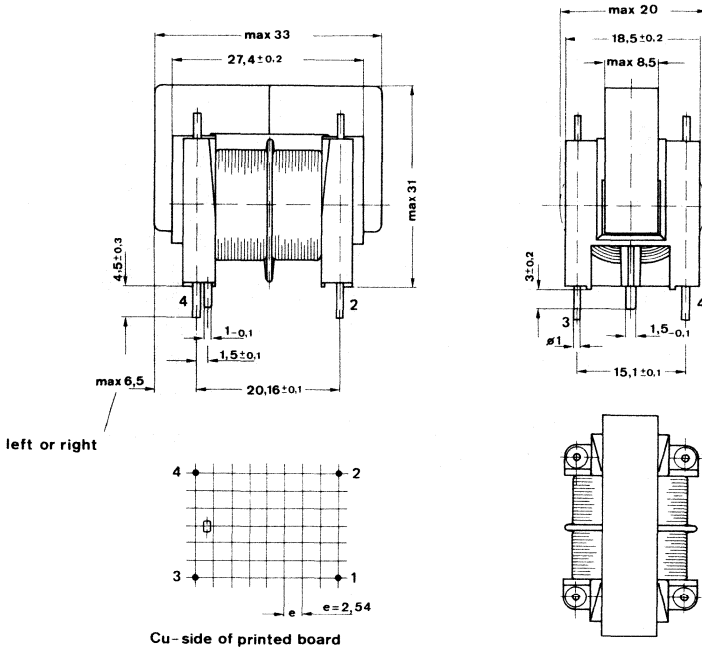

8086

ELECTRICAL DATA

	catalogue number						
Inductance* ($\pm 10\%$)	3112 138 53860	31112 338 30190	31112 338 30220	31112 338 30700	31112 338 30810	31112 338 30860	31111 108 33100
L ₁₋₂ = L ₃₋₄	12 mH	3,5 mH	1,7 mH	0,77 mH	64 mH	17,5 mH	28 mH
Resistance** ($\pm 12\%$)	0,44 Ω	0,21 Ω	0,44 Ω	0,26 Ω	1,7 Ω	0,48 Ω	1,0 Ω
R ₁₋₂ = R ₃₋₄							
Leakage inductance							
L ₁₍₁₋₂₎ = L ₁₍₃₋₄₎	0,5 mH						
Maximum current, I ₁₋₂	1400 mA	280 mA	950 mA	1260 mA	53 mA	100 mA	1000 mA

Test voltage (d.c.)

between windings

between windings and core

2000 V

2000 V

Approbation

Sets with chokes of this construction are released by Demko, Nemko, Semko, EI, SEV, UL and BSI.

TESTS

The choke withstands the following tests:

Vibration

Bump

Dry heat

Damp heat, steady state

Damp heat, accelerated

Rapid change of temperature

IEC 68-2-6, test Fc; 10-55-10 Hz, amplitude 0,35 mm

3 x 30 min

IEC 68-2-29, test Eb; 25g, 4000 bumps, 6 directions

IEC 68-2-2, test Bb; 96 h, + 125 °C

IEC 68-2-3, test Ca; 21 days, R.H. 95%

IEC 68-2-4, test Db; + 40 °C, R.H. 95 to 100%

IEC 68-2-14, test Na; 5 cycles, T_A = -25 °C,

T_B = + 100 °C

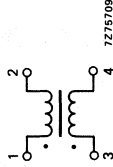

Diagram.

7275709

* Measured at 1 kHz, B_{max} = 0,1 T.

** Measured at T_{amb} = 23 °C.

CHOKE

- To be used as a choke or a transformer
- For consumer applications, e.g. monitors and television sets

DESCRIPTION

The magnetic circuit of the choke comprises two Ferroxcube U25 cores. The choke has 10 pins for mounting on a printed-wiring board.

MECHANICAL DATA

Dimensions in mm

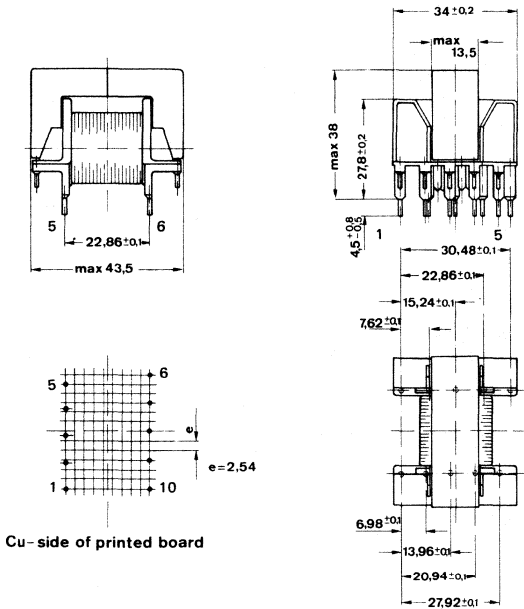

8093

ELECTRICAL DATA

	catalogue number			
	3112 338 30230	3112 338 30660	3122 138 50000	3122 138 50050
Inductance, primary* (tol. ± 10%)	(1-5) 150 mH	(8-2) 9 mH	(1-7) 25 mH	(1-10) 16 mH
Maximum current primary			(1-7) 560 mA	(1-10) 625 mA
Number of turns primary	(1-2) = 160 (2-3) = 80 (3-4) = 110 (4-5) = 165	(8-4) = 180 (4-2) = 162	(1-4) = 225 (4-7) = 225	(1-10) = 365
secondary	(6-7) = 1 (7-8) = 3 (8-9) = 3 (9-10) = 2			(3-2) = 62 (8-7) = 10
Diagram				

Test voltage (d.c.)
 between primary and secondary 2000 V
 between windings and core 500 V

Approbation

Sets with chokes of this construction are released by Demko, Nemko, Semko, EI, SEV, UL and BSI.

TESTS

The choke withstands the following tests:

- Vibration IEC 68-2-6, test Fc; 10-55-10 Hz, amplitude 0,35 mm
3 x 30 min
- Bump IEC 68-2-29, test Eb; 25g, 4000 bumps, 6 directions
- Dry heat IEC 68-2-2, test Bb; 96 h, +125 °C
- Damp heat, steady state IEC 68-2-3, test Ca; 21 days, R.H. 95%
- Damp heat, accelerated IEC 68-2-4, test Db; +40 °C, R.H. 95 to 100%
- Rapid change of temperature IEC 68-2-14, test Na; 5 cycles, T_A = -25 °C,
T_B = +100 °C

* Measured at 10 kHz, B_{max} = 0,1 T.

SWITCHED-MODE TRANSFORMER

- For consumer applications, e.g. monitors and television sets

DESCRIPTION

The magnetic circuit of the transformer comprises two Ferroxcube U25 cores. The primary and secondary windings are on separate coil formers, and concentrically mounted on one leg of the core. The transformer has 8 pins for mounting on a printed-wiring board.

MECHANICAL DATA

Dimensions in mm

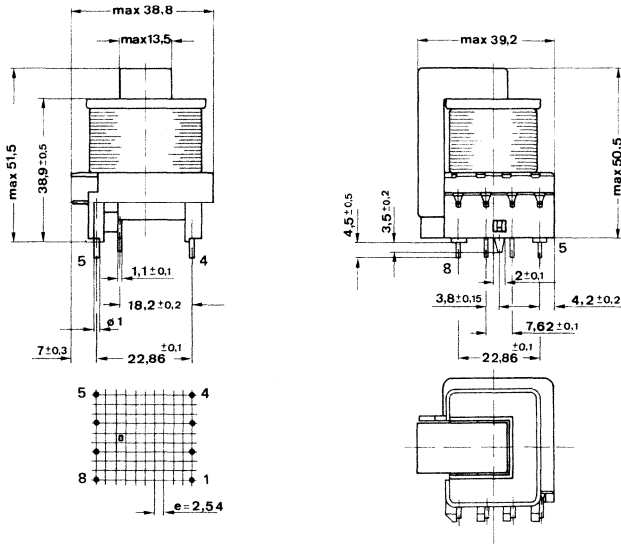

8104

ELECTRICAL DATA

catalogue number 3112 338 30120

Inductance, primary (3-4)	2,2 mH
Leakage inductance, primary (3-4)	4%
Number of turns, primary (3-4)	70
(1-2)	9
secondary (7-8)	14
(7-6)	17
(7-5)	8
(9-7)	8

Diagram

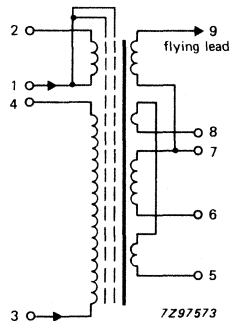

Test voltage (d.c.)	
between primary and secondary	5600 V
between primary and core	5600 V

Mains insulation according to IEC 65 class 2, VDE 0860

Approbation

Sets with transformers of this construction are released by Demko, Nemko, Semko, EI, SEV, UL and BSI.

TESTS

The transformer withstands the following tests:

Vibration	IEC 68-2-6, test Fc; 10-55-10 Hz, amplitude 0,35 mm 3 x 30 min
Bump	IEC 68-2-29, test Eb; 25g, 4000 bumps, 6 directions
Dry heat	IEC 68-2-2, test Bb; 96 h, +125 °C
Damp heat, steady state	IEC 68-2-3, test Ca; 21 days, R.H. 95%
Damp heat, accelerated	IEC 68-2-4, test Db; +40 °C, R.H. 95 to 100%
Rapid change of temperature	IEC 68-2-14, test Na; 5 cycles, T _A = -25 °C, T _B = +100 °C

* Measured at 1 kHz, B_{max} = 0,1 T.

ELECTRICAL DATA

catalogue number 3112 338 30150

Inductance (8-9)*	16 mH ± 10%
Resistance (8-9)**	1,65 Ω ± 12%
(6-7)**	0,054 Ω ± 12%
Maximum current (8-9)	1000 mA

Diagram

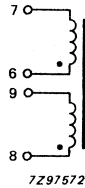

Test voltage (d.c.)
between windings 500 V

Approbation

Sets with chokes of this construction are released by Demko, Nemko, Semko, EI, SEV, UL and BSI.

TESTS

The choke withstands the following tests:

Vibration	IEC 68-2-6, test Fc; 10-55-10 Hz, amplitude 0,35 mm 3 x 30 min
Bump	IEC 68-2-29, test Eb; 25g, 4000 bumps, 6 directions
Dry heat	IEC 68-2-2, test Bb; 96 h, +125 °C
Damp heat, steady state	IEC 68-2-3, test Ca; 21 days, R.H. 95%
Damp heat, accelerated	IEC 68-2-4, test Db; +40 °C, R.H. 95 to 100%
Rapid change of temperature	IEC 68-2-14, test Na; 5 cycles, T _A = -25 °C, T _B = +100 °C

* Measured at 1 kHz, B_{max} = 0,1 T.

** Measured at T_{amb} = 23 °C.

CURRENT SENSING TRANSFORMER

- For switched-mode power supply circuits.
- For consumer applications, e.g. record players, cassette recorders, television sets.

DESCRIPTION

The magnetic circuit of the transformer comprises two Ferroxcube U15-cores. The primary turn is potted in the coil former to guarantee the required isolation. The transformer has 4 pins for mounting on a printed-wiring board.

MECHANICAL DATA

Dimensions in mm

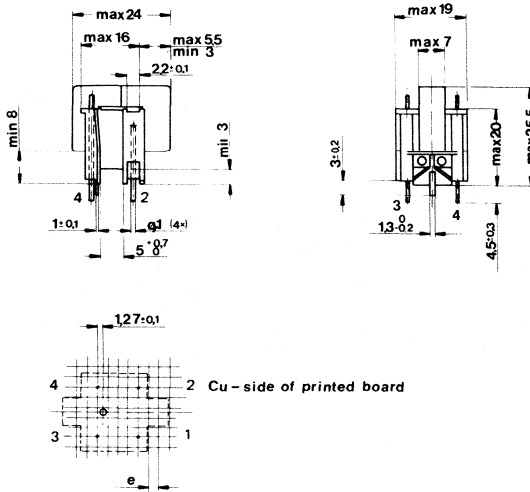

8118

ELECTRICAL DATA

Inductance (3-4)*
 Resistance (3-4)**
 Maximum current (1-2)
 Turns ratio
 Diagram

catalogue number	
3122 138 90300	3122 138 93390
> 700 mH	> 12,5 mH
44 Ω	1 Ω
2,5 A	10 A
1 : 800	1 : 100

Test voltage (d.c.) between primary and core
 Mains insulation

5600 V
 according to IEC 65 class 2,
 and VDE0860

Approbation

Sets with transformers of this construction are released by Demko, Nemko, Semko, EI, SEV, UL and BSI.

TESTS

The transformer withstands the following tests:

Vibration	IEC 68-2-6, test Fc; 10-55-10 Hz, amplitude 0,35 mm 3 x 30 min
Shock	IEC 68-2-29, test Eb; 25g, 4000 bumps, 6 directions
Dry heat	IEC 68-2-2, test Bb; 96 h, +125 °C
Damp heat, steady state	IEC 68-2-3, test Ca; 21 days, R.H. 95%
Damp heat, accelerated	IEC 68-2-4, test Db; +40 °C, R.H. 95 to 100%
Rapid change of temperature	IEC 68-2-14, test Na; 5 cycles, T _A = -25 °C, T _B = +100 °C

* Measured at 1 kHz, B_{max} = 0,1 T.

** Measured at T_{amb} = 23 °C.

MAINS TRANSFORMERS

MAINS TRANSFORMER

- Output power 8 VA
- For consumer applications, e.g. record players, cassette recorders, television sets

DESCRIPTION

This transformer has a laminated iron core (welded E-I combination). The primary and secondary windings are wound on separate coil formers, which are concentrically mounted on the centre leg of the E-I combination.

The transformer has 12 pins for mounting on printed-wiring boards (A), or solder tags with eyelets for wire connections (B).

MECHANICAL DATA

Dimensions in mm

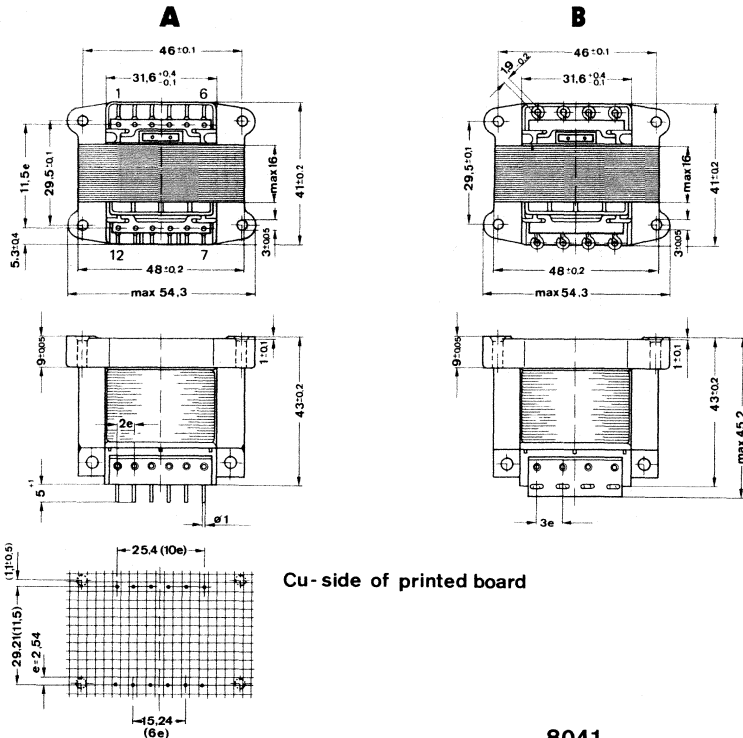

8041

Mounting

The transformer is secured by means of four self-tapping screws of 3 mm.

ELECTRICAL DATA

Output power at $T = 115\text{ }^{\circ}\text{C}$ ($T_{\text{amb}} = 60\text{ }^{\circ}\text{C}$)

8 VA

Note: for over-temperature protection a built-in temperature/current fuse for $123\text{ }^{\circ}\text{C}$ is used.

	catalogue number		
	3112 318 38130	3112 348 30110	3112 348 30330
Primary voltage	(3-5)* 110 V (3-1)* 127 V (3-2)** 220 V (3-1)** 240 V	(3-5) 110 V (3-2) 220 V (3-1) 240 V —	(3-5)* 110 V (3-1)* 127 V (3-2)** 220 V (3-1)** 240 V
Primary resistance (at $T_{\text{amb}} = 25\text{ }^{\circ}\text{C}$)	(3-5)* 150 Ω (3-1)* 202 Ω (3-2)** 600 Ω (3-1)** 652 Ω	(3-5) 250 Ω (3-2) 590 Ω (3-1) 649 Ω —	(3-5)* 105 Ω (3-1)* 140 Ω (3-2)** 420 Ω (3-1)** 455 Ω
Secondary voltage	(8-9) 17,3 V (10-11) 28,3 V	(9-10) 9,2 V (8-11) 21 V	(8-9) 12,5 V (9-11) 12,5 V
Secondary resistance (at $T_{\text{amb}} = 25\text{ }^{\circ}\text{C}$)	(8-9) 4,4 Ω (10-11) 110 Ω	(9-10) 2,1 Ω (8-11) 4,8 Ω	(8-9) 3,25 Ω (9-11) 3,25 Ω
Diagram			

Insulation resistance

between primary and secondary
between primary and core

> 60 M Ω
> 60 M Ω

Test voltage (d.c.)

between primary and secondary
between primary and core

5600 V
5600 V

Mains insulation

according to IEC 65 class 2,
VDE 0860

* (4-5) parallel connected to (6-2).

** Terminals 5 and 6 interconnected.

Approbation

Sets with transformers of this construction are released by Demko, Nemko, Semko, EI, SEV, UL and BSI.

TESTS

The mains transformer withstands the following tests:

Vibration	IEC 68-2-6, test Fc, 10-55-10 Hz, amplitude 0,35 mm, 3 x 30 min.
Bump	IEC 68-2-29, test Eb; 40g, 4000 bumps, 3 directions.
Dry heat	IEC 68-2-2, test Bb; 96 h, + 125 °C.
Damp heat, steady state	IEC 68-2-3, test Ca, 21 days, R.H. 95%.
Damp heat, accelerated	IEC 68-2-4, test D, + 55 °C, R.H. 95 to 100%.
Change of temperature	IEC 68-2-14, test Na; 5 cycles, $T_A = -25$ °C, $T_B = + 125$ °C.
Flammability	UL94, category V2.

MAINS TRANSFORMER

- Output power 8 VA
- For consumer applications, e.g. record players, cassette recorders, television sets

DESCRIPTION

This transformer has a laminated iron core (welded E-I combination). The primary and secondary windings are wound on separate coil formers, which are concentrically mounted on the centre leg of the E-I combination.

The transformer has 7 pins for mounting on printed-wiring boards.

MECHANICAL DATA

Dimensions in mm

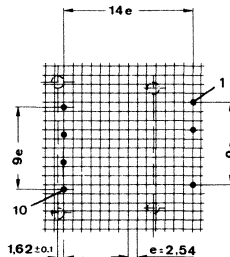
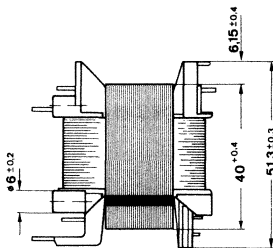
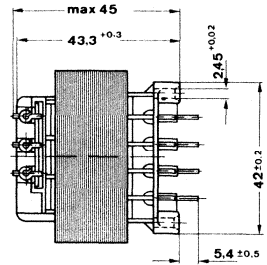
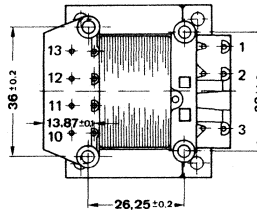
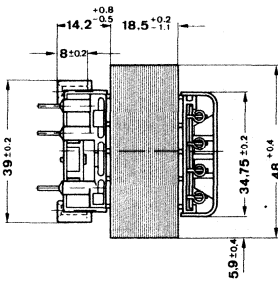

Cu-side of printed board

8048

Mounting

The transformer is secured by means of four self-tapping screws of 3 mm.

ELECTRICAL DATA

Output power at T = 115 °C (T_{amb} = 60 °C)

8 VA

Note: for over-temperature protection a built-in temperature/current fuse for 123 °C is used.

	catalogue number 3112 318			
	35730	36940	37490	39190
Primary voltage	(1-2) 220 V (1-2) 240 V	(1-2) 220 V	(1-2) 220 V	(1-2) 240 V
Primary resistance (at T _{amb} = 25 °C)	(1-2) 400 Ω	(1-2) 400 Ω	(1-2) 540 Ω	(1-2) 540 Ω
Secondary voltage	(10-11) 25,2 V* (11-13) 25,2 V*	(10-11) 10,5 V (11-13) 10,5 V	(10-13) 10,8 V	(10-13) 22,3 V
Secondary resistance (at T _{amb} = 25 °C)	(10-11) 14 Ω (11-13) 14 Ω	(10-11) 2,2 Ω (11-13) 2,2 Ω	(10-13) 1,5 Ω	(10-13) 5,6 Ω
Diagram				

Insulation resistance

between primary and secondary
between primary and core

> 60 MΩ
> 60 MΩ

Test voltage (d.c.)

between primary and secondary
between primary and core

5600 V
5600 V

Mains insulation

according to IEC 65 class 2,
VDE 0860

* At primary voltage of 220 V.

Approbation

Sets with transformers of this construction are released by Demko, Nemko, Semko, EI, SEV, UL and BSI.

TESTS

The mains transformer withstands the following tests:

Vibration	IEC 68-2-6, test Fc, 10-55-10 Hz, amplitude 0,35 mm, 3 x 30 min.
Bump	IEC 68-2-29, test Eb; 40g, 4000 bumps, 3 directions.
Dry heat	IEC 68-2-2, test Bb; 96 h, + 125 °C.
Damp heat, steady state	IEC 68-2-3, test Ca, 21 days, R.H. 95%.
Damp heat, accelerated	IEC 68-2-4, test D, + 55 °C, R.H. 95 to 100%.
Change of temperature	IEC 68-2-14, test Na; 5 cycles, T _A = -25 °C, T _B = + 125 °C.
Flammability	UL94, category V2.

MAINS TRANSFORMER

- Output power 25 VA
- For consumer applications, e.g. record players, cassette recorders, television sets

DESCRIPTION

This transformer has a laminated iron core (welded E-I combination). The primary and secondary windings are wound on separate coil formers, which are concentrically mounted on the centre leg of the E-I combination.

MECHANICAL DATA

Dimensions in mm

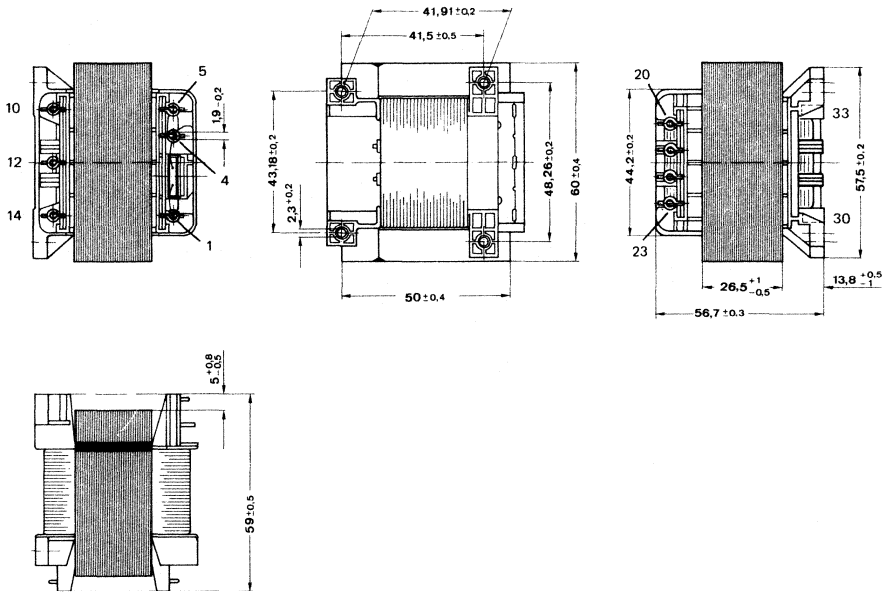

8103

Mounting

The transformer is secured by means of four self-tapping screws of 3 mm.

ELECTRICAL DATA

Output power at T = 115 °C (T_{amb} = 60 °C)

25 VA

Note: for over-temperature protection a built-in temperature/current fuse for 123 °C is used.

	catalogue number 3112			
	318 38020	318 39560	318 39970	348 30340*
Primary voltage	(4-5) 220 V	(4-12)** 110 V (4-14)** 127 V (4-5)▲ 220 V (4-14)▲ 240 V	(4-5) 220 V	(4-5) 120 V
Primary resistance (at T _{amb} = 25 °C)	(4-5) 79,5 Ω	(4-12)** 22,3 Ω (4-14)** 30,2 Ω (4-5)▲ 89,3 Ω (4-14)▲ 97,2 Ω	(4-5) 61 Ω	(4-5) 20,5 Ω
Secondary voltage	(20-23) 14,8 V	(20-21) 12,3 V (21-22) 12,3 V	(20-21) 9,7 V (22-23) 17,1 V	(32-31) 10,3 V (31-33) 10,3 V
Secondary resistance (at T _{amb} = 25 °C)	(20-23) 0,37 Ω	(20-21) 0,7 Ω (21-22) 0,7 Ω	(20-21) 0,19 Ω (22-23) 2,3 Ω	(32-31) 0,46 Ω (31-33) 0,46 Ω
Diagram				

Insulation resistance

between primary and secondary
between primary and core

> 60 MΩ
> 60 MΩ

Test voltage (d.c.)

between primary and secondary
between primary and core

5600 V
5600 V

Mains insulation

according to IEC 65 class 2,
VDE 0860

* UL approved.

** (1-12) parallel connected to (10-5).

▲ Terminals 10 and 12 interconnected.

Approbation

Sets with transformers of this construction are released by Demko, Nemko, Semko, EI, SEV, UL and BSI.

TESTS

The mains transformer withstands the following tests:

Vibration	IEC 68-2-6, test Fc, 10-55-10 Hz, amplitude 0,35 mm, 3 x 30 min.
Bump	IEC 68-2-29, test Eb; 40g, 4000 bumps, 3 directions.
Dry heat	IEC 68-2-2, test Bb; 96 h, + 125 °C.
Damp heat, steady state	IEC 68-2-3, test Ca, 21 days, R.H. 95%.
Damp heat, accelerated	IEC 68-2-4, test D, + 55 °C, R.H. 95 to 100%.
Change of temperature	IEC 68-2-14, test Na; 5 cycles, T _A = -25 °C, T _B = + 125 °C.
Flammability	UL94, category V2.

MAINS TRANSFORMER

- Output power 48 VA
- For consumer applications, e.g. record players, video recorders, television sets

DESCRIPTION

This transformer has a laminated iron core (welded E-I combination). The primary and secondary windings are wound on separate coil formers, which are concentrically mounted on the centre leg of the E-I combination.

MECHANICAL DATA

Dimensions in mm

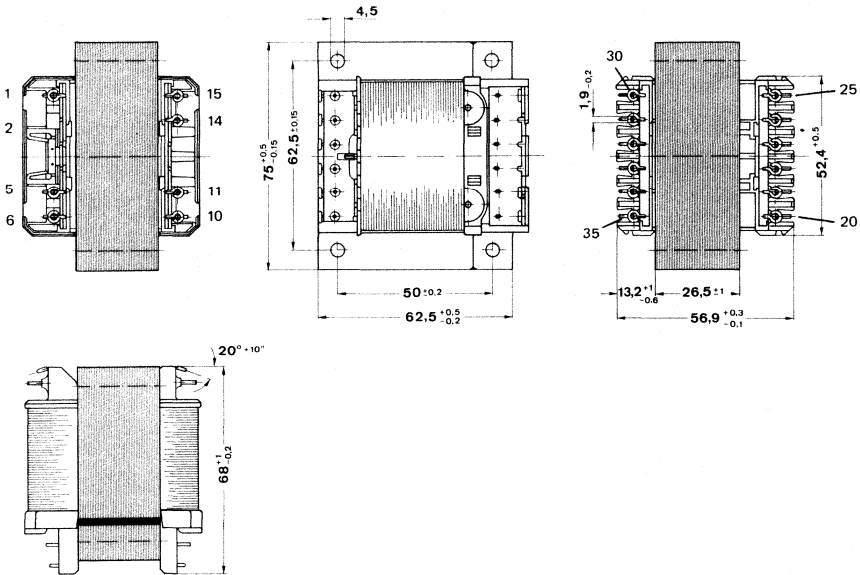

8061

Mounting

The transformers can be fitted with four screws M4; the mounting holes are positioned according to DIN 41302.

ELECTRICAL DATA

Output power at $T = 115\text{ }^{\circ}\text{C}$ ($T_{\text{amb}} = 60\text{ }^{\circ}\text{C}$)

48 VA

Note: for over-temperature protection a built-in temperature/current fuse for $123\text{ }^{\circ}\text{C}$ is used.

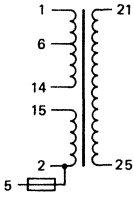
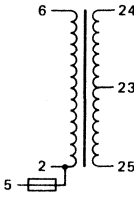
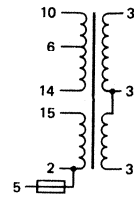
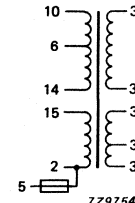
	catalogue number 3112			
	318 39480	318 39700	318 39990	348 30000
Primary voltage	(5-15)* 110 V (5-1)* 127 V (5-6)** 220 V (5-1)** 240 V	(5-6) 220 V	(5-6)* 110 V (5-10)* 127 V (5-6)** 220 V (5-10)** 240 V	(5-6)* 110 V (5-10)* 127 V (5-6)** 220 V (5-10)** 240 V
Primary resistance (at $T_{\text{amb}} = 25\text{ }^{\circ}\text{C}$)	(5-15)* 10,2 Ω (5-1)* 13,8 Ω (5-6)** 41 Ω (5-1)** 44,6 Ω	(5-6) 39 Ω	(5-6)* 9,5 Ω (5-10)* 13 Ω (5-6)** 38 Ω (5-10)** 41,5 Ω	(5-6)* 9,5 Ω (5-10)* 13 Ω (5-6)** 38 Ω (5-10)** 41,5 Ω
Secondary voltage	(21-25) 62,5 V	(24-23) 9,1 V (23-25) 9,1 V	(34-33) 18,8 V (33-30) 10,2 V	(34-35) 27 V (33-30) 10,6 V
Secondary resistance (at $T_{\text{amb}} = 25\text{ }^{\circ}\text{C}$)	(21-25) 3,1 Ω	(24-23) 0,16 Ω (23-25) 0,16 Ω	(34-33) 0,29 Ω (33-30) 2,6 Ω	(34-35) 0,8 Ω (33-30) 0,7 Ω
Diagram				

Insulation resistance

between primary and secondary
between primary and core

> 60 M Ω
> 60 M Ω

Test voltage (d.c.)

between primary and secondary
between primary and core

5600 V
5600 V

Main insulation

according to IEC 65 class 2,
VDE 0860

* (2-15) parallel connected to (14-6).

** Terminals 14 and 15 interconnected.

Approbation

Sets with transformers of this construction are released by Demko, Nemko, Semko, EI, SEV, UL and BSI.

TESTS

The mains transformer withstands the following tests:

Vibration	IEC 68-2-6, test Fc, 10-55-10 Hz, amplitude 0,35 mm, 3 x 30 min.
Bump	IEC 68-2-29, test Eb; 40g, 4000 bumps, 3 directions.
Dry heat	IEC 68-2-2, test Bb; 96 h, + 125 °C.
Damp heat, steady state	IEC 68-2-3, test Ca, 21 days, R.H. 95%.
Damp heat, accelerated	IEC 68-2-4, test D, + 55 °C, R.H. 95 to 100%.
Change of temperature	IEC 68-2-14, test Na; 5 cycles, $T_A = -25$ °C, $T_B = + 125$ °C.
Flammability	UL94, category V2.

MAINS TRANSFORMER

- Output power 60 VA
- For consumer applications, e.g. amplifiers, cassette recorders, television sets

DESCRIPTION

This transformer has a laminated iron core (welded E-I combination). The primary and secondary windings are wound on separate coil formers, which are concentrically mounted on the centre leg of the E-I combination.

The transformer has solder tags with eyelets for wire connections.

MECHANICAL DATA

Dimensions in mm

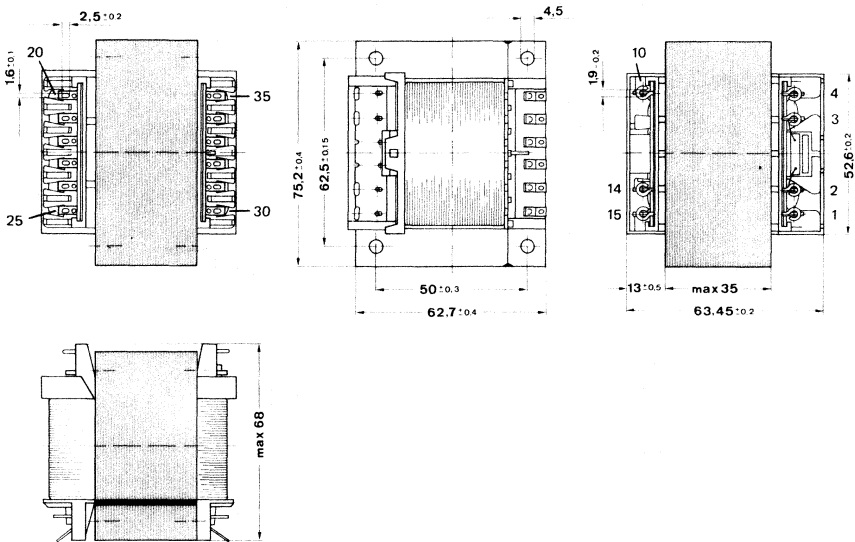

8054

Mounting

The transformers can be fitted with four screws M4; the mounting holes are positioned according to DIN 41302.

ELECTRICAL DATA

Output power at T = 115 °C (T_{amb} = 60 °C)

60 VA

Note: for over-temperature protection a built-in temperature/current fuse for 123 °C is used.

	catalogue number 3112 318			
	38620	38820	39010	39440*
Primary voltage	(3-4) 220 V (3-1) 240 V	(3-14)** 110 V (3-10)** 127 V (3-4)▲ 220 V (3-10)▲ 240 V	(3-4) 220 V	(1-4) 120 V
Primary resistance (at T _{amb} = 25 °C)	(3-4) 27 Ω (3-1) 29,3 Ω	(3-14)** 6,7 Ω (3-10)** 9,2 Ω (3-4)▲ 27 Ω (3-10)▲ 29,5 Ω	(3-4) 21 Ω	(1-4) 7,0 Ω
Secondary voltage	(20-21) 15,5 V	(34-33) 25,6 V (33-35) 25,6 V	(32-34) 28 V	(30-34) 17,2 V
Secondary resistance (at T _{amb} = 25 °C)	(20-21) 0,13 Ω	(34-33) 0,65 Ω (33-35) 0,65 Ω	(32-34) 0,37 Ω	(30-34) 0,18 Ω
Diagram				

Insulation resistance

between primary and secondary
between primary and core

> 60 MΩ
> 60 MΩ

Test voltage (d.c.)

between primary and secondary
between primary and core

5600 V
5600 V

Mains insulation

according to IEC 65 class 2,
VDE 0860

* Without temperature/current fuse.
** (1-14) parallel connected to (15-4).
▲ Terminals 14 and 15 interconnected.

Approbation

Sets with transformers of this construction are released by Demko, Nemko, Semko, EI, SEV, UL and BSI.

TESTS

The mains transformer withstands the following tests:

Vibration	IEC 68-2-6, test Fc, 10-55-10 Hz, amplitude 0,35 mm, 3 x 30 min.
Bump	IEC 68-2-29, test Eb; 40g, 4000 bumps, 3 directions.
Dry heat	IEC 68-2-2, test Bb; 96 h, + 125 °C.
Damp heat, steady state	IEC 68-2-3, test Ca, 21 days, R.H. 95%.
Damp heat, accelerated	IEC 68-2-4, test D, + 55 °C, R.H. 95 to 100%.
Change of temperature	IEC 68-2-14, test Na; 5 cycles, T _A = -25 °C, T _B = + 125 °C.
Flammability	UL94, category V2.

MAINS TRANSFORMER

- Output power 95 VA
- For consumer applications, e.g. amplifiers, cassette recorders, television sets

DESCRIPTION

This transformer has a laminated iron core (welded E-I combination). The primary and secondary windings are wound on separate coil formers, which are concentrically mounted on the centre leg of the E-I combination.

The transformer has solder tags with eyelets for wire connections.

MECHANICAL DATA

Dimensions in mm

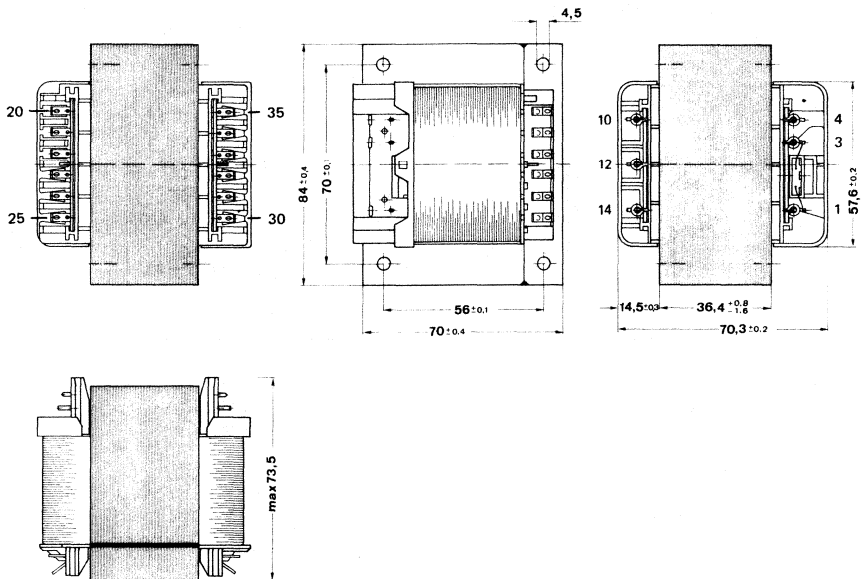

8064

Mounting

The transformers can be fitted with four screws M4; the mounting holes are positioned according to DIN 41302.

ELECTRICAL DATA

Output power at T = 115 °C (T_{amb} = 60 °C)

95 VA

Note: for over-temperature protection a built-in temperature/current fuse for 123 °C is used.

	catalogue number 3112 318			
	37600	38710*	39030	39640**
Primary voltage	(2-4) 220 V	(3-4) 120 V	(3-12)▲ 110 V (3-14)▲ 127 V (3-4)▲▲ 220 V (3-14)▲▲ 240 V	(1-3) 120 V (1-4) 240 V
Primary resistance (at T _{amb} = 25 °C)	(2-4) 13 Ω	(3-4) 3 Ω	(3-12)▲ 4 Ω (3-14)▲ 5,4 Ω (3-4)▲▲ 16,0 Ω (3-14)▲▲ 17,4 Ω	(1-3) 5,3 Ω (1-4) 23,5 Ω
Secondary voltage	(22-24) 29,8 V (24-23) 29,8 V	(24-23) 28,4 V (23-25) 28,4 V	(24-23) 27,2 V (23-25) 27,2 V	(30-34) 49,7 V
Secondary resistance (at T _{amb} = 25 °C)	(22-24) 0,6 Ω (24-23) 0,6 Ω	(24-23) 0,36 Ω (23-25) 0,36 Ω	(24-23) 0,55 Ω (23-25) 0,55 Ω	(30-34) 0,78 Ω
Diagram				

Insulation resistance

between primary and secondary
between primary and core

> 60 MΩ
> 60 MΩ

Test voltage (d.c.)

between primary and secondary
between primary and core

5600 V
5600 V

Mains insulation

according to IEC 65 class 2,
VDE 0860

* UL approved.

** UL and CSA approved.

▲ (1-12) parallel connected to (10-4).

▲▲ Terminals 10 and 12 interconnected.

Approbation

Sets with transformers of this construction are released by Demko, Nemko, Semko, EI, SEV, UL and BSI.

TESTS

The mains transformer withstands the following tests:

Vibration	IEC 68-2-6, test Fc, 10-55-10 Hz, amplitude 0,35 mm, 3 x 30 min.
Bump	IEC 68-2-29, test Eb; 40g, 4000 bumps, 3 directions.
Dry heat	IEC 68-2-2, test Bb; 96 h, + 125 °C.
Damp heat, steady state	IEC 68-2-3, test Ca, 21 days, R.H. 95%.
Damp heat, accelerated	IEC 68-2-4, test D, + 55 °C, R.H. 95 to 100%.
Change of temperature	IEC 68-2-14, test Na; 5 cycles, $T_A = -25$ °C, $T_B = + 125$ °C.
Flammability	UL94, category V2.

MAINS TRANSFORMER

- Output power 12 VA
- For consumer applications, e.g. record players, cassette recorders, television sets

DESCRIPTION

This transformer has a laminated iron core (welded E-I combination). The primary and secondary windings are wound on separate coil formers, which are concentrically mounted on the centre leg of the E-I combination.

The transformer has 12 pins for mounting on printed-wirings boards (A), or solder tags with eyelets for wire connections (B).

MECHANICAL DATA

Dimensions in mm

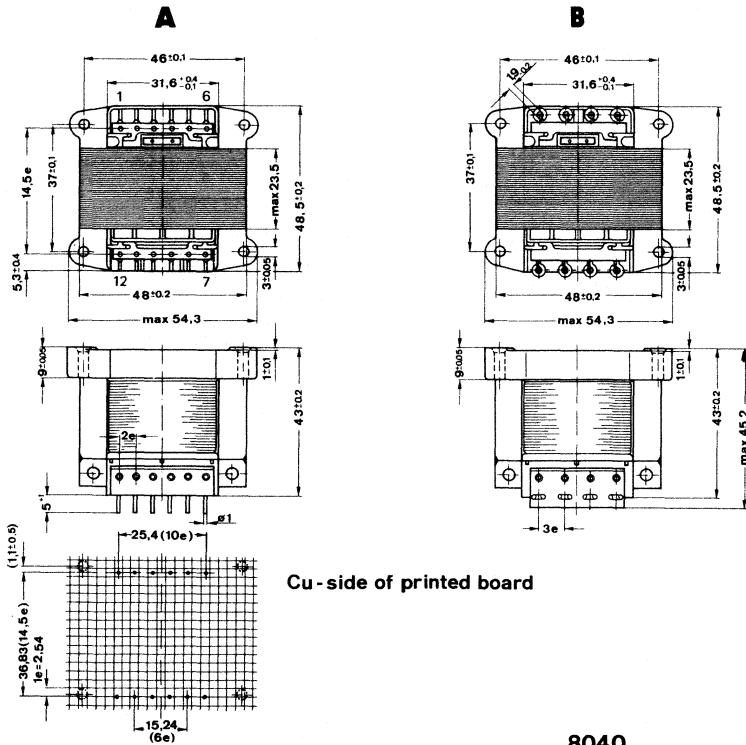

8040

Mounting

The transformer is secured by means of four self-tapping screws of 3 mm.

ELECTRICAL DATA

Output power at T = 115 °C (T_{amb} = 60 °C)

12 VA

Note: for over-temperature protection a built-in temperature/current fuse for 123 °C is used.

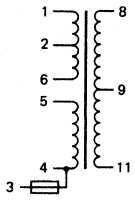
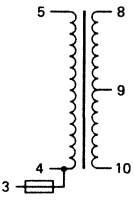
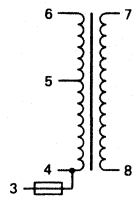
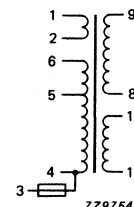
	catalogue number 3112			
	348 30410	318 39470	348 30190	348 30430*
Primary voltage	(3-5)** 110 V (3-1)** 127 V (3-2)▲ 220 V (3-1)▲ 240 V	(3-5) 240 V	(3-5) 127 V (3-6) 220 V	(3-5) 220 V (3-6) 240 V (1-2) 7,9 V —
Primary resistance (at T _{amb} = 25 °C)	(3-5)** 79 Ω (3-1)** 106 Ω (3-2)▲ 315 Ω (3-1)▲ 342 Ω	(3-5) 270 Ω	(3-5) 147 Ω (3-6) 275 Ω	(3-5) 268 Ω (3-6) 294 Ω
Secondary voltage	(8-9) 11,9 V (9-11) 11,9 V	(8-9) 18,3 V (9-10) 18,3 V	(7-8) 11,8 V	(11-10) 10,9 V (9-8) 21,5 V
Secondary resistance (at T _{amb} = 25 °C)	(8-9) 2,2 Ω (9-11) 2,2 Ω	(8-9) 3,7 Ω (9-10) 3,7 Ω	(7-8) 1,23 Ω	(11-10) 1,2 Ω (9-8) 18 Ω
Diagram				

Insulation resistance

between primary and secondary
between primary and core

> 60 MΩ
> 60 MΩ

Test voltage (d.c.)

between primary and secondary
between primary and core

5600 V
5600 V

Mains insulation

according to IEC 65 class 2,
VDE 0860

* Vacuum sealed, VDE 0551 approved.

** (4-5) parallel connected to (6-2).

▲ Terminals 5 and 6 interconnected.

Approbation

Sets with transformers of this construction are released by Demko, Nemko, Semko, EI, SEV, UL and BSI.

TESTS

The mains transformer withstands the following tests:

Vibration	IEC 68-2-6, test Fc, 10-55-10 Hz, amplitude 0,35 mm, 3 x 30 min.
Bump	IEC 68-2-29, test Eb; 40g, 4000 bumps, 3 directions.
Dry heat	IEC 68-2-2, test Bb; 96 h, + 125 °C.
Damp heat, steady state	IEC 68-2-3, test Ca, 21 days, R.H. 95%.
Damp heat, accelerated	IEC 68-2-4, test D, + 55 °C, R.H. 95 to 100%.
Change of temperature	IEC 68-2-14, test Na; 5 cycles, T _A = -25 °C, T _B = + 125 °C.
Flammability	UL94, category V2.

MAINS TRANSFORMER

- Output power 3,2 VA
- For consumer applications, e.g. record players, radio-cassette recorders

DESCRIPTION

This transformer has a laminated iron core (welded E-I combination). The primary and secondary windings are wound on separate coil formers, which are concentrically mounted on the centre leg of the E-I combination.

MECHANICAL DATA

Dimensions in mm

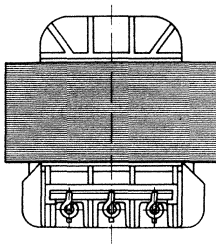
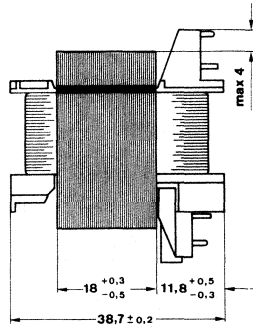
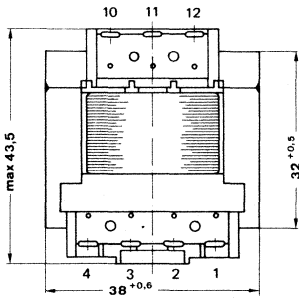

8067

ELECTRICAL DATA

Output power at $T = 115\text{ }^{\circ}\text{C}$ ($T_{\text{amb}} = 60\text{ }^{\circ}\text{C}$)

3,2 VA

Note: for over-temperature protection a built-in temperature/current fuse for $123\text{ }^{\circ}\text{C}$ is used.

	catalogue number 3112 318			
	36510	38000	38010	39410*
Primary voltage	(3-1) 127 V (3-4) 220 V (3-4) 240 V	(3-4) 220 V	(3-4) 240 V	(2-4) 120 V
Primary resistance (at $T_{\text{amb}} = 25\text{ }^{\circ}\text{C}$)	(3-1) 640 Ω (3-4) 1140 Ω	(3-4) 830 Ω	(3-4) 1140 Ω	(2-4) 290 Ω
Secondary voltage	(10-11) 10,3 V (11-12) 10,3 V	(10-12) 9,9 V	(10-12) 10 V	(10-12) 9,8 V
Secondary resistance (at $T_{\text{amb}} = 25\text{ }^{\circ}\text{C}$)	(10-11) 7 Ω (11-12) 7 Ω	(10-12) 1,7 Ω	(10-12) 1,8 Ω	(10-12) 1,7 Ω
Diagram				

Insulation resistance

between primary and secondary
between primary and core

> 60 M Ω
> 60 M Ω

Test voltage (d.c.)

between primary and secondary
between primary and core

5600 V
5600 V

Mains insulation

according to IEC 65 class 2,
VDE 0860

* Without fuse; UL approved.

Approbation

Sets with transformers of this construction are released by Demko, Nemko, Semko, EI, SEV, UL and BSI.

TESTS

The mains transformer withstands the following tests:

Vibration	IEC 68-2-6, test Fc, 10-55-10 Hz, amplitude 0,35 mm, 3 x 30 min.
Bump	IEC 68-2-29, test Eb; 40g, 4000 bumps, 3 directions.
Dry heat	IEC 68-2-2, test Bb; 96 h, + 125 °C.
Damp heat, steady state	IEC 68-2-3, test Ca, 21 days, R.H. 95%.
Damp heat, accelerated	IEC 68-2-4, test D, + 55 °C, R.H. 95 to 100%.
Change of temperature	IEC 68-2-14, test Na; 5 cycles, T _A = -25 °C, T _B = + 125 °C.
Flammability	UL94, category V2.

MAINS TRANSFORMER

- Output power 3,2 VA
- For consumer applications, e.g. record players, radio-cassette recorders, television sets

DESCRIPTION

This transformer has a laminated iron core (welded E-I combination). The primary and secondary windings are wound on separate coil formers, which are concentrically mounted on the centre leg of the E-I combination.

The transformer has 7 pins for mounting on printed-wiring boards.

MECHANICAL DATA

Dimensions in mm

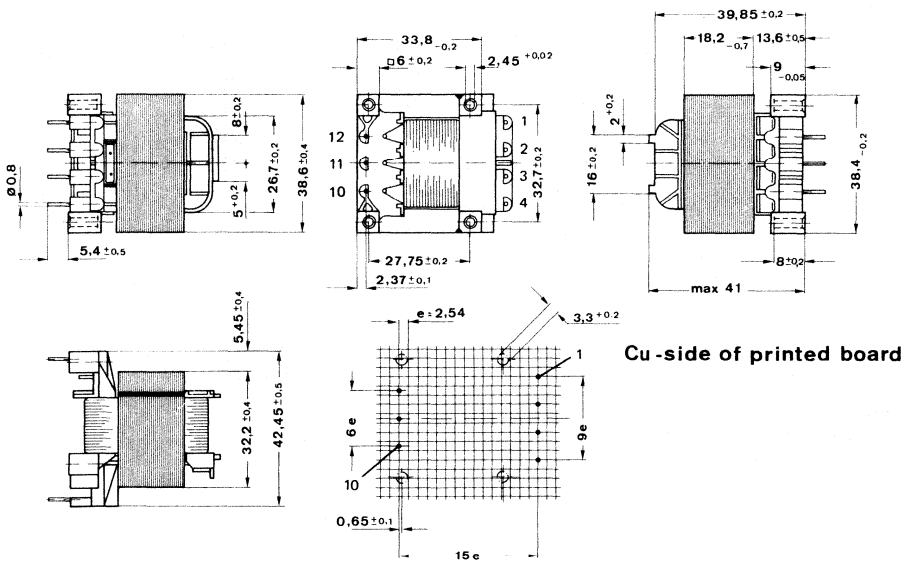

8060

Mounting

The transformer is secured by means of four self-tapping screws of 3 mm.

ELECTRICAL DATA

Output power at $T = 115\text{ }^{\circ}\text{C}$ ($T_{\text{amb}} = 60\text{ }^{\circ}\text{C}$)

3,2 VA

Note: for over-temperature protection a built-in temperature/current fuse for $123\text{ }^{\circ}\text{C}$ is used.

	catalogue number 3112			
	318 38210	318 39320*	318 39870**	348 30050
Primary voltage	(3-1) 115 V (3-4) 220 V	(2-1) 120 V	(3-1) 120 V (3-4) 230 V	(3-1) 127 V (3-4) 220 V (3-4) 240 V
Primary resistance (at $T_{\text{amb}} = 25\text{ }^{\circ}\text{C}$)	(3-1) 360 k Ω (3-4) 1430 Ω	(2-1) 150 Ω	(3-1) 850 Ω (3-4) 2100 Ω	(3-1) 640 Ω (3-4) 1140 Ω
Secondary voltage	(10-11) 8,8 V (11-12) 8,8 V	(10-12) 14,6 V	(10-11) 20 V (11-12) 20 V	(10-11) 10,3 V (11-12) 10,3 V
Secondary resistance (at $T_{\text{amb}} = 25\text{ }^{\circ}\text{C}$)	(10-11) 4,1 Ω (11-12) 4,1 Ω	(10-12) 2,4 Ω	(10-11) 38 Ω (11-12) 38 Ω	(10-11) 5,9 Ω (11-12) 5,9 Ω
Diagram				

Insulation resistance

between primary and secondary
between primary and core

> 60 M Ω
> 60 M Ω

Test voltage (d.c.)

between primary and secondary
between primary and core

5600 V
5600 V

Mains insulation

according to IEC 65 class 2,
VDE 0860

* UL approved.

** UL and CSA approved.

Approbation

Sets with transformers of this construction are released by Demko, Nemko, Semko, EI, SEV, UL and BSI.

TESTS

The mains transformer withstands the following tests:

Vibration	IEC 68-2-6, test Fc, 10-55-10 Hz, amplitude 0,35 mm, 3 x 30 min.
Bump	IEC 68-2-29, test Eb; 40g, 4000 bumps, 3 directions.
Dry heat	IEC 68-2-2, test Bb; 96 h, + 125 °C.
Damp heat, steady state	IEC 68-2-3, test Ca, 21 days, R.H. 95%.
Damp heat, accelerated	IEC 68-2-4, test D, + 55 °C, R.H. 95 to 100%.
Change of temperature	IEC 68-2-14, test Na; 5 cycles, T _A = -25 °C, T _B = + 125 °C.
Flammability	UL94, category V2.

**INDEX OF TYPE NUMBERS
CONVERSION LIST**

INDEX OF TYPE NUMBERS

type number	description	catalogue number	page
AT2076/51	diode-split line output transformer	3122 138 35990	15
AT2076/53	diode-split line output transformer	3122 138 36230	25
AT2076/54	universal diode-split line output transformer	3122 138 36310	35
AT2076/60	asynchronous power pack transformer	3122 138 35840	41
AT2076/70A	synchronous power pack transformer	3122 138 36440	47
AT2076/80	miniature diode-split line output transformer	3122 138 36290	53
AT2076/80A	miniature diode-split line output transformer	3122 138 36200	53
AT2076/81	miniature diode-split line output transformer	3122 138 36300	59
AT2076/81A	miniature diode-split line output transformer	3122 138 36240	59
AT2076/84	universal diode-split line output transformer	3122 138 36660	69
AT2077/80	diode-split-box line output transformer	3122 138 36560	75
AT2077/81	diode-split-box line output transformer	3122 138 36570	81
AT2077/82	diode-split-box line output transformer	3122 138 36580	89
AT2079/09	line output transformer	3122 138 37011	95
AT2079/10	line output transformer	3122 138 36922	101
AT2102/02	line output transformer	3122 138 35610	109
AT2102/02A	line output transformer	3122 138 37071	115
AT2102/04C	line output transformer	3111 108 34030	121
AT2102/06C	line output transformer	3111 108 34040	125
AT2140/00A	line output transformer	3111 108 35400	131
AT2140/16	line output transformer	3111 108 35570	135
AT2140/16B	line output transformer	3111 108 34450	139
AT2140/17	line output transformer	3111 108 35630	135
AT2250/14	line output transformer	3122 138 37121	143
AT3010/40	switched-mode transformer	3111 108 34390	283
AT3010/90L	switched-mode transformer	3111 108 35500	287
AT3010/110L	switched-mode transformer	3111 268 30010	289
AT3010/110LS	switched-mode transformer	3111 108 35690	293
AT4036/00A	adjustable linearity control unit	3122 138 57030	171
AT4042/04A	adjustable linearity control unit	3122 138 57050	173
AT4042/08A	adjustable linearity control unit	3122 138 56491	175
AT4042/30	linearity corrector	3122 138 97750	149
AT4042/32A	adjustable linearity control unit	3122 138 57080	177
AT4042/33A	adjustable linearity control unit	3122 138 57090	181
AT4042/34	linearity corrector	3122 138 55310	153
AT4042/35A	adjustable linearity control unit	3122 138 59101	183
AT4042/36FS	linearity corrector	3122 138 57760	155
AT4042/41FS	linearity corrector	3122 138 58281	157
AT4042/43A	adjustable linearity control unit	3122 138 58191	185
AT4042/46	linearity corrector	3122 138 98990	159

TYPE NUMBER INDEX

type number	description	catalogue number	page
AT4042/51FS	linearity corrector	3122 138 56330	161
AT4042/90	linearity corrector	3122 138 54000	163
AT4042/91	linearity corrector	3122 138 56660	165
AT4042/92	linearity corrector	3122 138 58621	167
AT4043/01	line driver transformer	3112 338 30140	297
AT4043/08A	east/west choke	3112 338 30700	299
AT4043/09	universal horizontal shift transformer	3112 338 30230	303
AT4043/16A	input choke	3112 338 30320	305
AT4043/17	driver transformer	3112 338 30330	309
AT4043/29	line driver/d.c. shift transformer	3122.138 73740	311
AT4043/45	switched-mode driver transformer	3122 138 90290	313
AT4043/46	current sensing transformer	3122 138 90300	315
AT4043/47	current sensing transformer	3122 138 93390	317
AT4043/48	thyristor trigger and transistor driver transformer	3122 138 90580	321
AT4043/52A	power pack system supply choke	3112 338 30660	325
AT4043/53	power pack system line choke	3122 138 93420	327
AT4043/55	mains filter choke	3122 138 93240	331
AT4043/56	line driver transformer	3111 108 32290	333
AT4043/59	line driver transformer	3122 138 93520	335
AT4043/60	east/west injection coil	3122 138 93870	337
AT4043/63	thyristor trigger and transistor driver transformer	3122 138 93400	321
AT4043/64	line driver transformer	8222 279 52121	339
AT4043/67	dynamic focusing transformer	3122 138 96570	341
AT4043/68	bridge coil	3122 138 96550	345
AT4043/69	bridge coil	3122 138 71800	347
AT4043/81	input choke	3122 138 50000	349
AT4043/82	driver transformer	3122 138 50240	351
AT4043/83	line driver transformer	3112 338 30160	353
AT4043/87	line driver transformer	3122 138 26060	355
AT4043/89	line driver transformer	3122 138 90070	357
AT4043/90	mains filter choke	3111 108 33100	359
AT4043/91A	mains filter choke	3112 338 30640	361
AT4043/92	mains filter choke	3122 138 52860	363
AT4043/93	mains filter choke	3122 138 53860	365
AT4043/100	bridge coil	3112 338 30830	367
AT4044/35	amplitude control unit	3122 138 56441	189
AT4044/39D	amplitude control unit	3122 138 57021	193
CE134h	switched-mode transformer	3112 338 30910	369
CE134v	switched-mode transformer	3112 338 30440	371
CE137h	switched-mode transformer	3112 338 30800	373
CE410	switched-mode transformer	*	375
CE411	switched-mode transformer	*	377
CE412v	switched-mode transformer	3112 338 30940	379
CE420	switched-mode transformer	*	381
CE440	switched-mode transformer	3112 338 30740	383
CF873	comb filter	4322 027 84581	261

* Various versions.

TYPE NUMBER INDEX

type number	description	catalogue number	page
CI10	bridge coil	*	385
CI10d2	pulse transformer	*	387
CI15	bridge coil	*	389
CI20	bridge coil	*	391
CU10	line driver transformer/bridge coil/choke	*	393
CU11b2	filter coil	*	395
CU15	line driver transformer/bridge coil/choke	*	397
CU15b2	filter coil	3112 338 30720	401
CU15d	mains filter choke	*	403
CU20	line driver transformer/bridge coil/choke	*	405
CU20c2	driver transformer	*	407
CU20d	mains filter choke	*	409
CU25	choke	*	411
CU25c2	switched-mode transformer	3112 338 30120	413
CU30	choke	3112 338 30150	415
CU150	current sensing transformer	*	417
DL63	glass delay line	4322 027 84630	217
DL270	luminance delay line	3122 138 99420	199
DL330	luminance delay line	3122 138 96042	203
DL390	luminance delay line	3122 138 50450	207
DL470	luminance delay line	3122 138 99471	211
DL680	glass delay line	4322 027 84661	221
DL701	glass delay line	4322 027 84771	225
DL703	glass delay line	4322 027 84831	229
DL711	glass delay line	4322 027 84781	233
DL720	glass delay line	4322 027 84721	237
DL721	glass delay line	4322 027 84731	237
DL722	glass delay line	4322 027 84741	237
DL750	glass delay line	4322 027 84751	241
DL752	glass delay line	4322 027 84882	245
DL872	glass delay line	4322 027 84841	249
DL875	glass delay line	4322 027 84501	253
DL876	glass delay line	4322 027 84511	257
TS519	mains transformer	*	421
TS521	mains transformer	*	425
TS522	mains transformer	*	429
TS523	mains transformer	*	433
TS524	mains transformer	*	437
TS525	mains transformer	*	441
TS531	mains transformer	*	445
TS561	mains transformer	*	449
TS561/3	mains transformer	*	453

* Various versions.

CONVERSION LIST

Conversion of catalogue number to type number.

catalogue number	description	type number	page
3111 108 32290	line driver transformer	AT4043/56	333
33100	mains filter choke	AT4043/90	359
34030	line output transformer	AT2102/04C	121
34040	line output transformer	AT2102/06C	125
34390	switched-mode transformer	AT3010/40	283
34450	line output transformer	AT2140/16B	139
35400	line output transformer	AT2140/00A	131
35500	switched-mode transformer	AT3010/90L	287
35570	line output transformer	AT2140/16	135
35630	line output transformer	AT2140/17	135
35690	switched-mode transformer	AT3010/110LS	293
3111 268 30010	switched-mode transformer	AT3010/110L	289
3112 318 35730	mains transformer	TS521	425
36510	mains transformer	TS561	449
36940	mains transformer	TS521	425
37490	mains transformer	TS521	425
37600	mains transformer	TS525	441
38000	mains transformer	TS561	449
38010	mains transformer	TS561	449
38020	mains transformer	TS522	429
38130	mains transformer	TS519	421
38210	mains transformer	TS561/3	453
38620	mains transformer	TS524	437
38710	mains transformer	TS525	441
38820	mains transformer	TS524	437
39010	mains transformer	TS524	437
39030	mains transformer	TS525	441
39190	mains transformer	TS521	425
39320	mains transformer	TS561/3	453
39410	mains transformer	TS561	449
39440	mains transformer	TS524	437
39470	mains transformer	TS531	445
39480	mains transformer	TS523	433
39560	mains transformer	TS522	429
39640	mains transformer	TS525	441
39700	mains transformer	TS523	433
39870	mains transformer	TS561/3	453
39970	mains transformer	TS522	429
39990	mains transformer	TS523	433

CONVERSION LIST

catalogue number	description	type number	page
3112 338 30070	line driver transformer/bridge coil/choke	CU10	393
30120	switched-mode transformer	CU25c2	413
30140	line driver transformer	AT4043/01	297
30150	choke	CU30	415
30160	line driver transformer	AT4043/83	353
30170	mains filter choke	CU15d	403
30190	mains filter choke	CU20d	409
30200	bridge coil	CI15	389
30210	choke	CU20	405
30220	mains filter choke	CU20d	409
30230	universal horizontal shift transformer	AT4043/09	303
30320	input choke	AT4043/16A	305
30330	driver transformer	AT4043/17	309
30380	driver transformer	CU20	405
30390	line driver transformer/bridge coil/choke	CU10	393
30420	driver transformer	CU15	397
30440	switched-mode transformer	CE134v	371
30460	bridge coil	CI10	385
30550	switched-mode transformer	CE411	377
30620	switched-mode transformer	CE420	381
30640	mains filter choke	AT4043/91A	361
30650	bridge coil	CI15	389
30660	power pack system supply choke	AT4043/52A	325
30700	east/west choke	AT4043/08A	299
30720	filter coil	CU15b2	401
30740	switched-mode transformer	CE440	383
30780	driver transformer	CU20c2	407
30790	bridge coil	CI10	385
30800	switched-mode transformer	CE137h	373
30810	mains filter choke	CU20d	409
30820	driver transformer	CU15	397
30830	bridge coil	AT4043/100	367
30840	driver transformer	CU15	397
30860	mains filter choke	CU20d	409
30880	line driver transformer/bridge coil/choke	CU10	393
30910	switched-mode transformer	CE134h	369
30920	bridge coil	CI20	391
30940	switched-mode transformer	CE412v	379
30970	switched-mode transformer	CE411	377
30980	driver transformer	CU15	397
31000	bridge coil	CU20	405
31010	pulse transformer	CI10d2	387
31020	mains filter choke	CU15d	403
31030	line driver transformer/bridge coil/choke	CU10	393
31040	switched-mode transformer	CE420	381
31070	switched-mode transformer	CE410	375

catalogue number	description	type number	page
3112 338 31090	line driver transformer/bridge coil/choke	CU10	393
31120	choke	CU15	397
31150	switched-mode transformer	CE410	375
31190	pulse transformer	CI10d2	387
3112 348 30000	mains transformer	TS523	433
30050	mains transformer	TS561/3	453
30110	mains transformer	TS519	421
30190	mains transformer	TS531	445
30330	mains transformer	TS519	421
30340	mains transformer	TS522	429
30410	mains transformer	TS531	445
30430	mains transformer	TS531	445
3122 138 26060	line driver transformer	AT4043/87	355
28870	bridge coil	CI20	391
29360	bridge coil	CI15	389
29390	bridge coil	CI15	389
35610	line output transformer	AT2102/02	109
35840	asynchronous power pack transformer	AT2076/60	41
35990	diode-split line output transformer	AT2076/51	15
36200	miniature diode-split line output transformer	AT2076/80A	53
36230	diode-split line output transformer	AT2076/53	25
36240	miniature diode-split line output transformer	AT2076/81A	59
36290	miniature diode-split line output transformer	AT2076/80	53
36300	miniature diode-split line output transformer	AT2076/81	59
36310	universal diode-split line output transformer	AT2076/54	35
36440	synchronous power pack transformer	AT2076/70A	47
36560	diode-split-box line output transformer	AT2077/80	75
36570	diode-split-box line output transformer	AT2077/81	81
36580	diode-split-box line output transformer	AT2077/82	89
36660	universal diode-split line output transformer	AT2076/84	69
36922	line output transformer	AT2079/10	101
37011	line output transformer	AT2079/09	95
37071	line output transformer	AT2102/02A	115
37121	line output transformer	AT2250/14	143
50000	input choke	AT4043/81	349
50050	choke	CU25	411
50240	driver transformer	AT4043/82	351
50450	luminance delay line	DL390	207
51020	filter coil	CU11b2	395
51850	degaussing coil		267
51860	degaussing coil		267
52560	mains filter choke	CU15d	403

CONVERSION LIST

catalogue number	description	type number	page
3122 138 52860	mains filter choke	AT4043/92	363
53860	mains filter choke	AT4043/93	365
54000	linearity corrector	AT4042/90	163
55220	degaussing coil		269
55230	degaussing coil		269
55260	degaussing coil		271
55310	linearity corrector	AT4042/34	153
55920	degaussing coil		273
56070	degaussing coil		275
56170	degaussing coil		275
56310	degaussing coil		277
56320	degaussing coil		277
56330	linearity corrector	AT4042/51FS	161
56441	amplitude control unit	AT4044/35	189
56491	adjustable linearity control unit	AT4042/08A	175
56660	linearity corrector	AT4042/91	165
57021	amplitude control unit	AT4044/39D	193
57030	adjustable linearity control unit	AT4036/00A	171
57050	adjustable linearity control unit	AT4042/04A	173
57080	adjustable linearity control unit	AT4042/32A	177
57090	adjustable linearity control unit	AT4042/33A	181
57760	linearity corrector	AT4042/36FS	155
58191	adjustable linearity control unit	AT4042/43A	185
58281	linearity corrector	AT4042/41FS	157
58621	linearity corrector	AT4042/92	167
59101	adjustable linearity control unit	AT4042/35A	183
71330	bridge coil	CI10	385
71800	bridge coil	AT4043/69	347
73740	line driver/d.c. shift transformer	AT4043/29	311
74290	bridge coil	CI10	385
74310	bridge coil	CI10	385
90070	line driver transformer	AT4043/89	357
90290	switched-mode driver transformer	AT4043/45	313
90300	current sensing transformer	AT4043/46	315
90580	thyristor trigger and transistor driver transformer	AT4043/48	321
93240	mains filter choke	AT4043/55	331
93390	current sensing transformer	AT4043/47	317
93400	thyristor trigger and transistor driver transformer	AT4043/63	321
93420	power pack system line choke	AT4043/53	327
93520	line driver transformer	AT4043/59	335
93870	east/west injection coil	AT4043/60	337
94810	bridge coil	CI20	391
95450	driver transformer	CU15	397
96042	luminance delay line	DL330	203
96550	bridge coil	AT4043/68	345

CONVERSION LIST

catalogue number	description	type number	page
3122 138 96570	dynamic focusing transformer	AT4043/67	341
97750	linearity corrector	AT4042/30	149
98990	linearity corrector	AT4042/46	159
99420	luminance delay line	DL270	199
99460	filter coil	CU11b2	395
99471	luminance delay line	DL470	211
99840	degaussing coil		279
99850	degaussing coil		279
4322 027 84501	glass delay line	DL875	253
84511	glass delay line	DL876	257
84581	comb filter	CF873	261
84631	glass delay line	DL63	217
84661	glass delay line	DL680	221
84721	glass delay line	DL720	237
84731	glass delay line	DL721	237
84741	glass delay line	DL722	237
84751	glass delay line	DL750	241
84752	glass delay line	DL750	241
84771	glass delay line	DL701	225
84772	glass delay line	DL701	225
84781	glass delay line	DL711	233
84782	glass delay line	DL711	233
84831	glass delay line	DL703	229
84841	glass delay line	DL872	249
84882	glass delay line	DL752	245
8222 279 52121	line driver transformer	AT4043/64	339

Argentina: PHILIPS ARGENTINA S.A., Div. Elcoma, Vedia 3892, 1430 BUENOS AIRES, Tel. 541-7141/7242/7343/7444/7545.
Australia: PHILIPS INDUSTRIES HOLDINGS LTD., Elcoma Division, 11 Waltham Street, ARTARMON, N.S.W. 2064, Tel. (02) 439 3322.
Austria: ÖSTERREICHISCHE PHILIPS BAUELEMENTE INDUSTRIE G.m.b.H., Triester Str. 64, A-1101 WIEN, Tel. 62 91 11-0.
Belgium: N.V. PHILIPS & MBLE ASSOCIATED, 9 rue du Pavillon, B-1030 BRUXELLES, Tel. (02) 242 74 00.
Brazil: IBRAPE, Caixa Postal 7383, Av. Brigadeiro Faria Lima, 1735 SAO PAULO, SP, Tel. (011) 211-2600.
Canada: PHILIPS ELECTRONICS LTD., Elcoma Division, 601 Milner Ave., SCARBOROUGH, Ontario, M1B 1M8, Tel. 292-5161.
Chile: PHILIPS CHILENA S.A., Av. Santa Maria 0760, SANTIAGO, Tel. 39-4001.
Colombia: IND. PHILIPS DE COLOMBIA S.A., c/o IPRELENZO LTD., Cra. 21, No. 56-17, BOGOTA, D.E., Tel. 249 76 24.
Denmark: MINIWATT A/S, Strandlodsvej 2, P.O. Box 1919, DK 2300 COPENHAGEN S, Tel. (01) 54 11 33.
Finland: OY PHILIPS AB, Elcoma Division, Kaivokatu 8, SF-00100 HELSINKI 10, Tel. 1 72 71.
France: RTC-COMPELEC, 130 Avenue Ledru Rollin, F-75540 PARIS 11, Tel. 43 38 80 00.
Germany (Fed. Republic): VALVO, UB Bauelemente der Philips G.m.b.H., Valvo Haus, Burchardstrasse 19, D-2 HAMBURG 1, Tel. (040) 3296-0.
Greece: PHILIPS HELLENIQUE S.A., Elcoma Division, 54, Syngrou Av., ATHENS 11742, Tel. 92 1531/1319.
Hong Kong: PHILIPS HONG KONG LTD., Elcoma Div., 15/F Philips Ind. Bldg., 24-28 Kung Yip St., KWAI CHUNG, Tel. (0)-24 51 21.
India: PEICO ELECTRONICS & ELECTRICALS LTD., Elcoma Dept., Band Box Building, 254-D Dr. Annie Besant Rd., BOMBAY - 400 025, Tel. 493031/1/4930590.
Indonesia: P.T. PHILIPS-RALIN ELECTRONICS, Elcoma Div., Setiabudi II Building, 6th Fl., Jalan H.R. Rasuna Said (P.O. Box 223/KBY) Kuningan, JAKARTA - Selatan, Tel. 512 572.
Ireland: PHILIPS ELECTRICAL (IRELAND) LTD., Newstead, Clonskeagh, DUBLIN 14, Tel. 69 33 55.
Italy: PHILIPS S.p.A., Sezione Elcoma, Piazza IV Novembre 3, I-20124 MILANO, Tel. 2-6752.1.
Japan: NIHON PHILIPS CORP., Shuwa Shinagawa Bldg., 26-33 Takanawa 3-chome, Minato-ku, TOKYO (108), Tel. 448-5611. (IC Products) SIGNETICS JAPAN LTD., 8-7 Sanbancho Chiyoda-ku, TOKYO 102, Tel. (03) 230-1521.
Korea (Republic of): PHILIPS ELECTRONICS (KOREA) LTD., Elcoma Div., Philips House, 260-199 Itaewon-dong, Yongsan-ku, SEOUL, Tel. 794-5011.
Malaysia: PHILIPS MALAYSIA SDN. BERHAD, No. 4 Persiaran Barat, Petaling Jaya, P.O.B. 2163, KUALA LUMPUR, Selangor, Tel. 77 44 11.
Mexico: ELECTRONICA, S.A de C.V., Carr. México-Toluca km. 62.5, TOLUCA, Edo. de México 50140, Tel. Toluca 91 (721) 613-00.
Netherlands: PHILIPS NEDERLAND, Marktgroep Elcoma, Postbus 90050, 5600 PB EINDHOVEN, Tel. (040) 7933 33.
New Zealand: PHILIPS NEW ZEALAND LTD., Elcoma Division, 110 Mt. Eden Road, C.P.O. Box 1041, AUCKLAND, Tel. 605-914.
Norway: NORSK A/S PHILIPS, Electronica Dept., Sandstuveien 70, OSLO 6, Tel. 68 02 00.
Peru: CADESA, Av. Alfonso Ugarte 1268, LIMA 5, Tel. 326070.
Philippines: PHILIPS INDUSTRIAL DEV. INC., 2246 Pasong Tamo, P.O. Box 911, Makati Comm. Centre, MAKATI-RIZAL 3116, Tel. 86-89-51 to 59.
Portugal: PHILIPS PORTUGUESA S.A.R.L., Av. Eng. Duarte Pacheco 6, 1009 LISBOA Codex, Tel. 68 31 21.
Singapore: PHILIPS PROJECT DEV. (Singapore) PTE LTD., Elcoma Div., Lorong 1, Toa Payoh, SINGAPORE 1231, Tel. 35 02 000.
South Africa: EDAC (PTY.) LTD., 3rd Floor Rainer House, Upper Railway Rd. & Ove St., New Doornfontein, JOHANNESBURG 2001, Tel. 614-2362/9.
Spain: MINIWATT S.A., Balmes 22, BARCELONA 7, Tel. 301 63 12.
Sweden: PHILIPS KOMPLEMENTER A.B., Lidingövägen 50, S-11584 STOCKHOLM 27, Tel. 08/7821000.
Switzerland: PHILIPS A.G., Elcoma Dept., Allmendstrasse 140-142, CH-8027 ZÜRICH, Tel. 01-488 22 11.
Taiwan: PHILIPS TAIWAN LTD., 150 Tun Hua North Road, P.O. Box 22978, TAIPEI, Taiwan, Tel. 71 20500.
Thailand: PHILIPS ELECTRICAL CO. OF THAILAND LTD., 283 Silom Road, P.O. Box 961, BANGKOK, Tel. 233-6330-9.
Turkey: TÜRK PHILIPS TICARET A.S., Elcoma Department, İnönü Cad. No. 78-80, P.K.504, 80074 ISTANBUL, Tel. 43 59 10.
United Kingdom: MULLARD LTD., Mullard House, Torrington Place, LONDON WC1E 7HD, Tel. 01-580 6633.
United States: (Active Devices & Materials) AMPEREX SALES CORP., Providence Pike, SLATERSVILLE, R.I. 02876, Tel. (401) 762-9000. (Passive Devices) MEPCO/ELECTRA INC., Columbia Rd., MORRISTOWN, N.J. 07960, Tel. (201) 539-2000. (Passive Devices & Electromechanical Devices) CENTRALAB INC., 5855 N. Glen Park Rd., MILWAUKEE, WI 53201, Tel. (414) 228-7380. (IC Products) SIGNETICS CORPORATION, 811 East Arques Avenue, SUNNYVALE, California 94086, Tel. (408) 991-2000.
Uruguay: LUZIELECTRON S.A., Avda Uruguay 1287, P.O. Box 907, MONTEVIDEO, Tel. 91 43 21.
Venezuela: IND. VENEZOLANAS PHILIPS S.A., c/o MAGNETICA S.A., Calle 6, Ed. Las Tres Jotas, App. Post. 78117, CARACAS, Tel. (02) 239 39 31.

For all other countries apply to: Philips Electronic Components and Materials Division, International Business Relations, P.O. Box 218, 5600 MD EINDHOVEN, The Netherlands, Telex 35000 phtcnl